

**UNITED STATES
SECURITIES AND EXCHANGE COMMISSION**
WASHINGTON, D.C. 20549

FORM 8-K

CURRENT REPORT
PURSUANT TO SECTION 13 OR 15(D)
OF THE SECURITIES EXCHANGE ACT OF 1934

Date of Report (Date of earliest event reported): October 19, 2021

Apollo Global Management, Inc.

(Exact name of registrant as specified in its charter)

Delaware
(State or other jurisdiction of incorporation)

001-35107
(Commission File Number)

20-8880053
(IRS Employer Identification No.)

9 West 57th Street, 43rd Floor
New York, New York 10019
(Address of principal executive offices) (Zip Code)

(212) 515-3200
(Registrant's telephone number, including area code)

N/A
(Former Name or Former Address, if Changed Since Last Report)

Check the appropriate box below if the Form 8-K filing is intended to simultaneously satisfy the filing obligation of the registrant under any of the following provisions (see General Instruction A.2. below):

- Written communications pursuant to Rule 425 under the Securities Act (17 CFR 230.425)
- Soliciting material pursuant to Rule 14a-12 under the Exchange Act (17 CFR 240.14a-12)
- Pre-commencement communications pursuant to Rule 14d-2(b) under the Exchange Act (17 CFR 240.14d-2(b))
- Pre-commencement communications pursuant to Rule 13e-4(c) under the Exchange Act (17 CFR 240.13e-4(c))

Securities registered pursuant to Section 12(b) of the Act:

<u>Title of each class</u>	<u>Trading Symbol(s)</u>	<u>Name of each exchange on which registered</u>
Class A Common Stock	APO	New York Stock Exchange
6.375% Series A Preferred Stock	APO.PR A	New York Stock Exchange
6.375% Series B Preferred Stock	APO.PR B	New York Stock Exchange

Indicate by check mark whether the registrant is an emerging growth company as defined in Rule 405 of the Securities Act of 1933 (17 CFR §230.405) or Rule 12b-2 of the Securities Exchange Act of 1934 (17 CFR §240.12b-2).

Emerging growth company

If an emerging growth company, indicate by check mark if the registrant has elected not to use the extended transition

period for complying with any new or revised financial accounting standards provided pursuant to Section 13(a) of the Exchange Act.

Item 7.01 Regulation FD Disclosure.

In connection with its previously announced Investor Day for stockholders and analysts scheduled for today, October 19, 2021, at 8:30 a.m. ET, Apollo Global Management, Inc. ("AGM") has made available to investors a supplemental presentation on AGM's website (the "Supplemental Presentation").

The information included under this Item 7.01, "Regulation FD Disclosure" of Current Report on Form 8-K is being furnished. As such, the information herein shall not be deemed to be "filed" for the purposes of Section 18 of the Securities Exchange Act of 1934, as amended (the "Exchange Act"), or otherwise subject to the liabilities of that Section, nor shall it be incorporated by reference into a filing under the Securities Act of 1933, as amended (the "Securities Act"), or the Exchange Act, except as shall be expressly set forth by specific reference in such a filing.

Item 8.01 Other Items.

In addition to the Supplemental Presentation, AGM has made available to stockholders and analysts attending today's Investor Day a presentation that is attached hereto as Exhibit 99.1 (the "Investor Day Presentation"). The Investor Day Presentation is also available on AGM's website.

* * *

The information in this Current Report on Form 8-K, including Exhibit 99.1, contains forward-looking statements that are within the meaning of Section 27A of the Securities Act and Section 21E of the Exchange Act. These statements include, but are not limited to, discussions related to AGM's expectations regarding the performance of its business, its liquidity and capital resources and the other non-historical statements in the discussion and analysis. These forward-looking statements are based on management's beliefs, as well as assumptions made by, and information currently available to, management. When used in this Current Report on Form 8-K, the words "believe," "anticipate," "estimate," "expect," "intend" and similar expressions are intended to identify forward-looking statements. Although management believes that the expectations reflected in these forward-looking statements are reasonable, it can give no assurance that these expectations will prove to have been correct. It is possible that actual results will differ, possibly materially, from the anticipated results indicated in these statements. These statements are subject to certain risks, uncertainties and assumptions, including risks relating to AGM's dependence on certain key personnel, AGM's ability to raise new private equity, credit or real assets funds, the impact of COVID-19, the impact of energy market dislocation, market conditions, generally, AGM's ability to manage its growth, fund performance, changes in AGM's regulatory environment and tax status, the variability of AGM's revenues, net income and cash flow, AGM's use of leverage to finance its businesses and investments by AGM funds, litigation risks and consummation of the merger of AGM with Athene Holding Ltd. ("AHL"), potential governance changes and related transactions which are subject to regulatory, corporate and shareholders approvals, among others. Due to the COVID-19 pandemic, there has been uncertainty and disruption in the global economy and financial markets. While AGM is unable to accurately predict the full impact that COVID-19 will have on AGM's results from operations, financial condition, liquidity and cash flows due to numerous uncertainties, including the duration and severity of the pandemic and containment measures, AGM's compliance with these measures has impacted AGM's day-to-day operations and could disrupt AGM's business and operations, as well as that of the AGM funds and their portfolio companies, for an indefinite period of time. AGM believes these factors include but are not limited to those described under the section entitled "Risk Factors" in AGM's annual report on Form 10-K filed with the SEC on February 19, 2021 and Quarterly Report on Form 10-Q filed with the SEC on May 10, 2021, as such factors may be updated from time to time in AGM's periodic filings with the SEC, which are accessible on the SEC's website at www.sec.gov. These factors should not be construed as exhaustive and should be read in conjunction with the other cautionary statements that are included in this Current Report on Form 8-K and in other filings.

AGM undertakes no obligation to publicly update or review any forward-looking statements, whether as a result of new information, future developments or otherwise, except as required by applicable law. This Current Report on Form 8-K does not constitute an offer of any AGM fund.

* * *

Item 9.01 Financial Statements and Exhibits.

(d) Exhibits

<u>Exhibit No.</u>	<u>Description</u>
99.1	Investor Day Presentation
104	Cover Page Interactive Data File (embedded within the Inline XBRL document)

Additional Information Regarding the Transaction and Where to Find It

This Current Report on Form 8-K is being made in respect of the proposed transaction involving Tango Holdings, Inc., a Delaware corporation and a direct wholly owned subsidiary of AGM (“HoldCo”), AGM and AHL. The proposed transaction will be submitted to the stockholders of AGM and the shareholders of AHL for their respective consideration. In connection therewith, the parties intend to file relevant materials with the Securities and Exchange Commission (the “SEC”), including a definitive joint proxy statement/prospectus, which will be mailed to the stockholders of AGM and the shareholders of AHL. However, such documents are not currently available. BEFORE MAKING ANY VOTING OR ANY INVESTMENT DECISION, AS APPLICABLE, INVESTORS AND SECURITY HOLDERS OF AGM AND AHL ARE URGED TO READ THE DEFINITIVE JOINT PROXY STATEMENT/PROSPECTUS REGARDING THE PROPOSED TRANSACTION AND ANY OTHER RELEVANT DOCUMENTS FILED OR TO BE FILED WITH THE SEC CAREFULLY AND IN THEIR ENTIRETY WHEN THEY BECOME AVAILABLE BECAUSE THEY WILL CONTAIN IMPORTANT INFORMATION ABOUT THE PROPOSED TRANSACTION. Investors and security holders may obtain free copies of the definitive joint proxy statement/prospectus, any amendments or supplements thereto and other documents containing important information about AGM and AHL, once such documents are filed with the SEC, through the website maintained by the SEC at www.sec.gov.

Copies of the documents filed with the SEC by AGM will be available free of charge under the “Stockholders” section of AGM’s website located at <http://www.apollo.com> or by contacting AGM’s Investor Relations Department at (212) 822-0528 or APOInvestorRelations@apollo.com.

Copies of the documents filed with the SEC by AHL will be available free of charge under the “Investors” section of AHL’s website located at <http://www.athene.com> or by contacting AHL’s Investor Relations Department at (441) 279-8531 or ir@athene.com.

Participants in the Solicitation

AGM, AHL, HoldCo and their respective directors, executive officers, members of management and employees may, under the rules of the SEC, be deemed to be participants in the solicitation of proxies in connection with the proposed transaction.

Information about the directors and executive officers of AGM and HoldCo is set forth in AGM’s proxy statement for its 2020 annual meeting of stockholders, which was filed with the SEC on August 20, 2020, its annual report on Form 10-K for the fiscal year ended December 31, 2020, which was filed with the SEC on February 19, 2021, and in subsequent documents filed with the SEC, each of which can be obtained free of charge from the sources indicated above.

Information about the directors and executive officers of AHL is set forth in AHL’s proxy statement for its 2020 annual meeting of shareholders, which was filed with the SEC on April 21, 2020, its annual report on Form 10-K for the fiscal year ended December 31, 2020, which was filed with the SEC on February 19, 2021, and in subsequent documents filed with the SEC, each of which can be obtained free of charge from the sources indicated above.

Other information regarding the participants in the proxy solicitations of the stockholders of AGM and the shareholders of AHL, and a description of their direct and indirect interests, by security holdings or otherwise, will be contained in the preliminary and definitive joint proxy statement/prospectus and other relevant materials to be filed with the SEC when they become available.

No Offer or Solicitation

This Current Report on Form 8-K is for informational purposes only and not intended to and does not constitute an offer to subscribe for, buy or sell, the solicitation of an offer to subscribe for, buy or sell or an invitation to subscribe for, buy or sell any securities or the solicitation of any vote or approval in any jurisdiction pursuant to or in connection with the proposed transaction or otherwise, nor shall there be any sale, issuance or transfer of securities in any jurisdiction in contravention of applicable law.

SIGNATURES

Pursuant to the requirements of the Securities Exchange Act of 1934, as amended, the Registrant has duly caused this report to be signed on its behalf by the undersigned hereunto duly authorized.

Global Management, Inc.
/ John J. Suydam
Name: John J. Suydam
Title: Chief Legal Officer

APOLLO

INVESTOR DAY 2021



Forward Looking Statements and Important Disclosures

This presentation has been prepared by Apollo Global Management, Inc., a Delaware corporation (together with its subsidiaries, "Apollo") solely for informational purposes for its public stockholders in connection with evaluating the business, operations and financial results of Apollo and Athene Holding Ltd., a Bermuda exempted company (together with its subsidiaries, "Athene"), and assumes that the previously announced merger of Apollo and Athene will be successfully consummated.

Information and data in the materials are as of June 30, 2021 unless otherwise noted, including information and data labeled "2021", "Current", "Today" and similar labeled content. Information and data labeled "Tomorrow" is prospective and aspirational and not intended to denote a particular date in the future unless otherwise noted.

Apollo makes no representation or warranty, express or implied, as to the fairness, accuracy, reasonableness or completeness of the information contained herein, including, but not limited to, information obtained from third parties. Unless otherwise specified, information included herein is sourced from and reflects the views and opinions of Apollo Analysts. Certain information contained in these materials has been obtained from sources other than Apollo. While such information is believed to be reliable for purposes used herein, no representations are made as to the accuracy or completeness thereof and Apollo does not take any responsibility for such information. This presentation may contain trade names, trademarks and service marks of companies which (i) neither Apollo nor Apollo Funds own or (ii) are investments of Apollo or one or more Apollo Funds. We do not intend our use or display of these companies' trade names, trademarks or service marks to imply a relationship with, or endorsement or sponsorship of us by, such companies. Certain information contained in the presentation discusses general market activity, industry or sector trends, or other broad-based economic, market or political conditions and should not be construed as research or investment advice. This presentation is not complete and the information contained herein may change at any time without notice. Apollo does not have any responsibility to update the presentation to account for such changes. The information contained herein is not intended to provide, and should not be relied upon for, accounting, legal or tax advice or investment recommendations.

No Offer or Solicitation

This presentation is for informational purposes only and not intended to and does not constitute an offer to subscribe for, buy or sell, the solicitation of an offer to subscribe for, buy or sell or an invitation to subscribe for, buy or sell any securities, products or services, including interests in the funds, vehicles or accounts sponsored or managed by Apollo (each, an "Apollo Fund"), any capital markets services offered by Apollo, or the solicitation of any vote or approval in any jurisdiction pursuant to or in connection with the proposed transaction or otherwise, nor shall there be any sale, issuance or transfer of securities in any jurisdiction in contravention of applicable law.

Additional Information Regarding the Transaction and Where to Find It

This presentation is being made in respect of the proposed transaction involving Tango Holdings, Inc., a Delaware corporation and a direct wholly owned subsidiary of Apollo ("HoldCo"), Apollo and Athene. The proposed transaction will be submitted to the stockholders of Apollo and the shareholders of Athene for their respective consideration. In connection therewith, the parties intend to file relevant materials with the Securities and Exchange Commission (the "SEC"), including a definitive joint proxy statement/prospectus, which will be mailed to the stockholders of Apollo and the shareholders of Athene. However, such documents are not currently available. BEFORE MAKING ANY VOTING OR ANY INVESTMENT DECISION, AS APPLICABLE, INVESTORS AND SECURITY HOLDERS OF APOLLO AND ATHENE ARE URGED TO READ THE DEFINITIVE JOINT PROXY STATEMENT/PROSPECTUS REGARDING THE PROPOSED TRANSACTION AND ANY OTHER RELEVANT DOCUMENTS FILED OR TO BE FILED WITH THE SECURITIES AND EXCHANGE COMMISSION ("SEC") CAREFULLY AND IN THEIR ENTIRETY WHEN THEY BECOME AVAILABLE BECAUSE THEY WILL CONTAIN IMPORTANT INFORMATION ABOUT THE PROPOSED TRANSACTION. Investors and security holders may obtain free copies of the definitive joint proxy statement/prospectus, any amendments or supplements thereto and other documents containing important information about Apollo and Athene, once such documents are filed with the SEC, through the website maintained by the SEC at <http://www.sec.gov>.

Copies of the documents filed with the SEC by Apollo will be available free of charge under the "Stockholders" section of Apollo's website located at <http://www.apollo.com> or by contacting Apollo's Investor Relations Department at (212) 822-0528 or ir@apollo.com.

Copies of the documents filed with the SEC by Athene will be available free of charge under the "Investors" section of Athene's website located at <http://www.athene.com> or by contacting Athene's Investor Relations Department at (441) 279-8531 or ir@athene.com.

Participants in the Solicitation

Apollo, Athene, HoldCo and their respective directors, executive officers, members of management and employees may, under the rules of the SEC, be deemed to be participants in the solicitation of proxies in connection with the proposed transaction.

Information about the directors and executive officers of Apollo and HoldCo is set forth in Apollo's proxy statement for its 2021 annual meeting of stockholders, which was filed with the SEC on August 16, 2021, its annual report on Form 10-K for the fiscal year ended December 31, 2020, which was filed with the SEC on February 19, 2021, and in subsequent documents filed with the SEC, each of which can be obtained free of charge from the sources indicated above.

Information about the directors and executive officers of Athene is set forth in Athene's proxy statement for its 2021 annual meeting of shareholders, which was filed with the SEC on July 22, 2021, its annual report on Form 10-K for the fiscal year ended December 31, 2020, which was filed with the SEC on February 19, 2021, its amendment to its annual report on Form 10-K/A for the fiscal year ended December 31, 2020, which was filed with the SEC on April 20, 2021, and in subsequent documents filed with the SEC, each of which can be obtained free of charge from the sources indicated above.

Forward Looking Statements and Important Disclosures

Other information regarding the participants in the proxy solicitations of the stockholders of Apollo and the shareholders of Athene, and a description of their direct and indirect interests, by security holdings or otherwise, will be contained in the preliminary and definitive joint proxy statement/prospectus and other relevant materials to be filed with the SEC when they become available.

Forward Looking Statements

Apollo Safe Harbor for Forward Looking Statements Disclaimer

This presentation contains forward-looking statements that are within the meaning of Section 27A of the Securities Act of 1933, as amended, and Section 21E of the Securities Exchange Act of 1934, as amended. These statements include, but are not limited to, discussions related to Apollo's expectations regarding the performance of its business, its liquidity and capital resources and the other non-historical statements in the discussion and analysis. These forward-looking statements are based on management's beliefs, as well as assumptions made by, and information currently available to, management. When used in this presentation, the words "believe," "anticipate," "estimate," "expect," "intend," "may," "will," "could," "should," "might," "target," "project," "plan," "seek," "continue" and similar expressions are intended to identify forward-looking statements. Although management believes that the expectations reflected in these forward-looking statements are reasonable, it can give no assurance that these expectations will prove to have been correct. It is possible that actual results will differ, possibly materially, from the anticipated results indicated in these statements. These statements are subject to certain risks, uncertainties and assumptions, including risks relating to Apollo's dependence on certain key personnel, Apollo's ability to raise new Apollo Funds, the impact of COVID-19, the impact of energy market dislocation, market conditions, generally, Apollo's ability to manage its growth, fund performance, changes in Apollo's regulatory environment and tax status, the variability of Apollo's revenues, net income and cash flow, Apollo's use of leverage to finance its businesses and investments by Apollo Funds, litigation risks and consummation of the merger of Apollo with Athene, potential governance changes and related transactions which are subject to regulatory, corporate and shareholders approvals, among others. Due to the COVID-19 pandemic, there has been uncertainty and disruption in the global economy and financial markets. While Apollo is unable to accurately predict the full impact that COVID-19 will have on Apollo's results from operations, financial condition, liquidity and cash flows due to numerous uncertainties, including the duration and severity of the pandemic and containment measures, Apollo's compliance with these measures has impacted Apollo's day-to-day operations and could disrupt Apollo's business and operations, as well as that of the Apollo Funds and their portfolio companies, for an indefinite period of time. Apollo believes these factors include but are not limited to those described under the section entitled "Risk Factors" in Apollo's annual report on Form 10-K filed with the SEC on February 19, 2021 and Quarterly Report on Form 10-Q filed with the SEC on May 10, 2021, as such factors may be updated from time to time in Apollo's periodic filings with the SEC, which are accessible on the SEC's website at <http://www.sec.gov>. These factors should not be construed as exhaustive and should be read in conjunction with the other cautionary statements that are included in this presentation and in other filings.

The proposed transaction is subject to risks, uncertainties and assumptions, which include, but are not limited to: (i) that Apollo may be unable to complete the proposed transaction because, among other reasons, conditions to the closing of the proposed transaction may not be satisfied or waived, including that a governmental entity may prohibit, delay or refuse to grant or place material restrictions on its approval for the consummation of the proposed transaction; (ii) uncertainty as to the timing of completion of the proposed transaction; (iii) the inability to complete the proposed transaction due to the failure to obtain Apollo stockholder approval and Athene shareholder approval for the proposed transaction; (iv) the occurrence of any event, change or other circumstances that could give rise to the termination of the merger agreement; (v) risks related to disruption of management's attention from Apollo's ongoing business operations due to the proposed transaction; (vi) the effect of the announcement of the proposed transaction on Apollo's relationships with its clients, operating results and business generally; (vii) the outcome of any legal proceedings to the extent initiated against Apollo or others following the announcement of the proposed transaction, as well as Apollo's management's response to any of the aforementioned factors; and (viii) industry conditions.

Apollo undertakes no obligation to publicly update or review any forward-looking statements, whether as a result of new information, future developments or otherwise, except as required by applicable law. This presentation does not constitute an offer of any Apollo Fund.

Athene Safe Harbor for Forward-Looking Statements

This presentation contains, and certain oral statements made by Athene's representatives from time to time may contain, forward-looking statements within the meaning of the Private Securities Litigation Reform Act of 1995, Section 27A of the Securities Act of 1933, as amended, and Section 21E of the Securities Exchange Act of 1934, as amended. Such statements are subject to risks and uncertainties that could cause actual results, events and developments to differ materially from those set forth in, or implied by, such statements. These statements are based on the beliefs and assumptions of Athene's management and the management of Athene's subsidiaries.

Generally, forward-looking statements include actions, events, results, strategies and expectations and are often identifiable by use of the words "believes," "expects," "intends," "anticipates," "plans," "seeks," "estimates," "projects," "may," "will," "could," "might," or "continues" or similar expressions. Forward looking statements within this presentation include, but are not limited to, statements regarding: the consummation of the proposed merger and the benefits to be derived therefrom; the future financial performance and growth prospects of the combined entity; the market environment in which the combined entity will operate; future capital allocation decisions, including the payment of dividends; the structure and operation of the company post-merger; and the tax treatment of the proposed transaction.

Forward Looking Statements and Important Disclosures

Factors that could cause actual results, events and developments to differ include, without limitation: Athene's failure to obtain approval of the proposed transaction by its shareholders or regulators; Athene's failure to recognize the benefits expected to be derived from the proposed transaction; unanticipated difficulties or expenditures relating to the proposed transaction; disruptions of Athene's current plans, operations and relationships with customers, suppliers and other business partners caused by the announcement and pendency of the proposed transaction; legal proceedings, including those that may be instituted against Athene, Athene's board of directors or special committee, Athene's executive officers and others following announcement of the proposed transaction; the accuracy of Athene's assumptions and estimates; Athene's ability to maintain or improve financial strength ratings; Athene's ability to manage its business in a highly regulated industry; regulatory changes or actions; the impact of Athene's reinsurers failing to meet their assumed obligations; the impact of interest rate fluctuations; changes in the federal income tax laws and regulations; the accuracy of Athene's interpretation of the Tax Cuts and Jobs Act, litigation (including class action litigation), enforcement investigations or regulatory scrutiny; the performance of third parties; the loss of key personnel; telecommunication, information technology and other operational systems failures; the continued availability of capital; new accounting rules or changes to existing accounting rules; general economic conditions; Athene's ability to protect its intellectual property; the ability to maintain or obtain approval of the Delaware Department of Insurance, the Iowa Insurance Division and other regulatory authorities as required for Athene's operations; and other factors discussed from time to time in Athene's filings with the SEC, including its annual report on Form 10-K for the year ended December 31, 2020 and quarterly report on Form 10-Q filed for the period ended June 30, 2021, which can be found at the SEC's website at <http://www.sec.gov>.

All forward-looking statements described herein are qualified by these cautionary statements and there can be no assurance that the actual results, events or developments referenced herein will occur or be realized. Athene does not undertake any obligation to update or revise forward-looking statements to reflect changed assumptions, the occurrence of unanticipated events or changes to future operating results.

The contents of any website referenced in this presentation are not incorporated by reference.

Performance Information

Past performance is not necessarily indicative of future results and there can be no assurance that Apollo, Athene or any Apollo Fund or strategy will achieve comparable results, or that any investments made by Apollo in the future will be profitable. Actual realized value of currently unrealized investments will depend on, among other factors, future operating results, the value of the assets and market conditions at the time of disposition, any related transaction costs and the timing and manner of sale, all of which may differ from the assumptions and circumstances on which the current unrealized valuations are based. Accordingly, the actual realized values of unrealized investments may differ materially from the values indicated herein.

Information contained herein may include information with respect to prior investment performance of one or more Apollo and Athene funds or investments, including gross and/or net internal rates of return ("IRR") and gross and/or net multiple of investment cost ("MOIC"). Information with respect to prior performance, while a useful tool in evaluating investment activities, is not necessarily indicative of actual results that may be achieved for unrealized investments. The realization of such performance is dependent upon many factors, many of which are beyond the control of Apollo. Aggregated return information is not reflective of an investable product, and as such does not reflect the returns of any Apollo Fund.

Please refer to the Appendix for additional important information.

**INVESTOR
DAY 2021**

Welcome Remarks

NOAH GUNN

Global Head of Investor Relations





Investor Day Agenda

TIME	TOPIC	PRESENTER	
8:30AM – 9:30AM	Welcome Remarks	Noah Gunn	Global Head of Investor Relations
	Strategy & Outlook	Marc Rowan	Co-Founder & Chief Executive Officer
	Culture at Apollo	Video	
5 MINUTE BREAK			
9:35AM – 10:30AM	Yield Overview	Jim Zelter	Co-President
	Origination Platforms	Chris Edson	Senior Partner, Co-Head of US FIG
	Capital Solutions	Craig Farr	Senior Partner, Capital Solutions
	Equity & Hybrid Overview	Scott Kleinman	Co-President
10 MINUTE BREAK			
10:40AM – 11:35AM	Retirement Services Overview	Scott Kleinman	Co-President
	Athene	Jim Belardi	Athene Chairman, Chief Executive Officer, & Chief Investment Officer
	Client & Product Solutions	Stephanie Drescher	Chief Client & Product Development Officer
	FinTech	Blythe Masters	Founding Partner, Motive Partners
	Expanding Opportunity	Video Introduced by Jonathan Simon	Head of Leadership Development & Diversity, Equity and Inclusion
10 MINUTE BREAK			
11:45AM – 1:00PM	Financial Overview & Strategy	Martin Kelly	Chief Financial Officer & Co-Chief Operating Officer
	Closing and Q&A	Marc Rowan, Jim Zelter, Scott Kleinman, and Martin Kelly	

+ Supplemental Presentations for Yield, Private Equity, and Hybrid Investing available on our website

We've Delivered Strong Growth and Financial Returns

	2016	2021	% Change	5-Year CAGR
 \$186 billion AUM	\$472 billion AUM	+153%	+20%	
 \$87 billion Permanent Capital Vehicles ¹	\$277 billion Permanent Capital Vehicles ¹	+219%	+26%	
 \$459 million LTM Fee Related Earnings ¹	\$1.1 billion LTM Fee Related Earnings ¹	+148%	+20%	

Note: Figures as of June 30, 2016 and June 30, 2021, respectively. 1. Please refer to the Definitions pages at the end of this presentation for the definition of fee related earnings and permanent capital.

INVESTOR
DAY 2021

Strategy & Outlook

MARC ROWAN

Co-Founder & Chief Executive Officer



AN AMAZING 31-YEAR JOURNEY

\$472B

Total Assets Under
Management across
Yield, Hybrid, and Equity
Investing Strategies

2,000+

Employees Around
the World

\$40B

Pro-Forma Market
Capitalization and
S&P 500 Eligible



* AUM as of June 30, 2021. Employees as of September 30, 2021. Market Cap based on current APO share price as of October 15, 2021 and pro-forma for post-merger share count of approximately 600mm shares, including anticipated equity awards related to compensation reset.

APOLLO INVESTOR DAY 2021

We Can't Underestimate
the Importance of Culture

"Culture eats
strategy for
breakfast."

-PETER DRUCKER

APOLLO INVESTOR DAY 2021

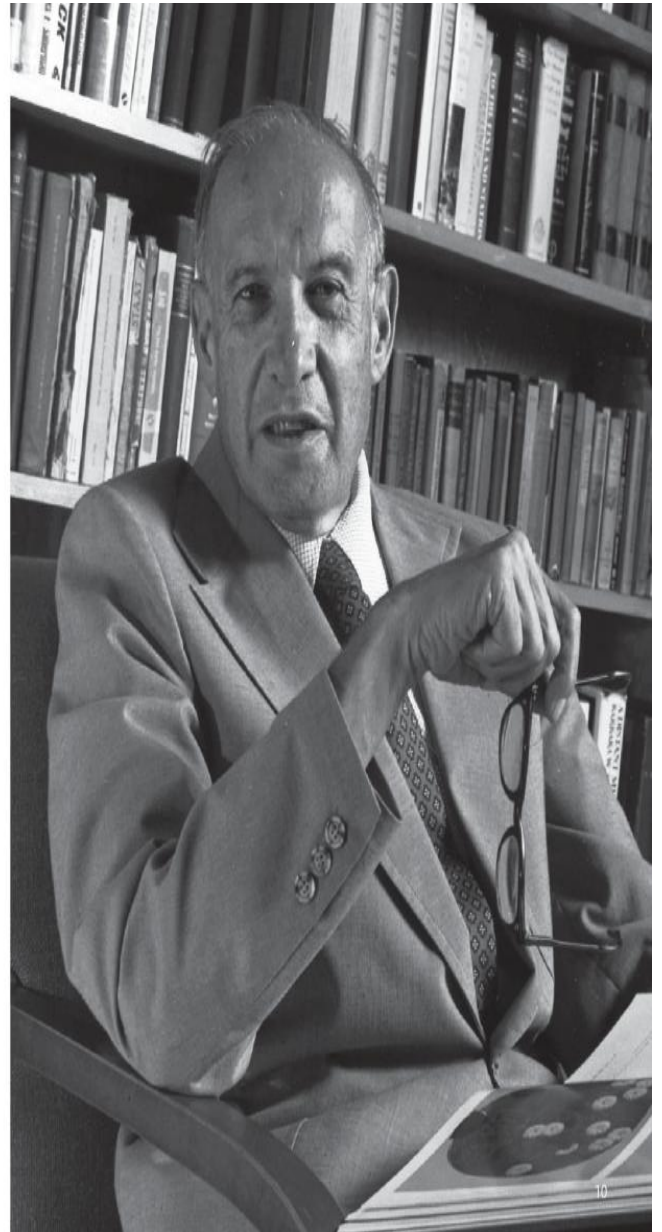

People and Culture Are at the Core of What We Do



Five Key Takeaways

- 1 High growth base plan** over next 5 years
 - ~2x AUM
 - ~2.25x Fee Revenue + earnings on ~\$5 billion of growth capital¹
 - ~2.5x FRE
- 2 Largest addressable market** among alternatives peers
 - Unique ecosystem built for massive credit opportunity
- 3 Athene is a competitive differentiator** and **growth accelerant**
 - Merger has many strategic benefits and allows us to capture large amounts of undervalued spread earnings
- 4 Our model is highly capital efficient**
 - \$15 billion of capital generation over next 5 years to accelerate growth and return to shareholders
- 5 Strong momentum** behind aligned team
 - Industry's best talent, aligned with changes to compensation philosophy

1. Pro-forma for announced merger with Athene.
APOLLO INVESTOR DAY 2021

1

High Growth Base Plan Over The Next 5 Years

Apollo is a High Growth Alternative Asset Manager

APOLLO

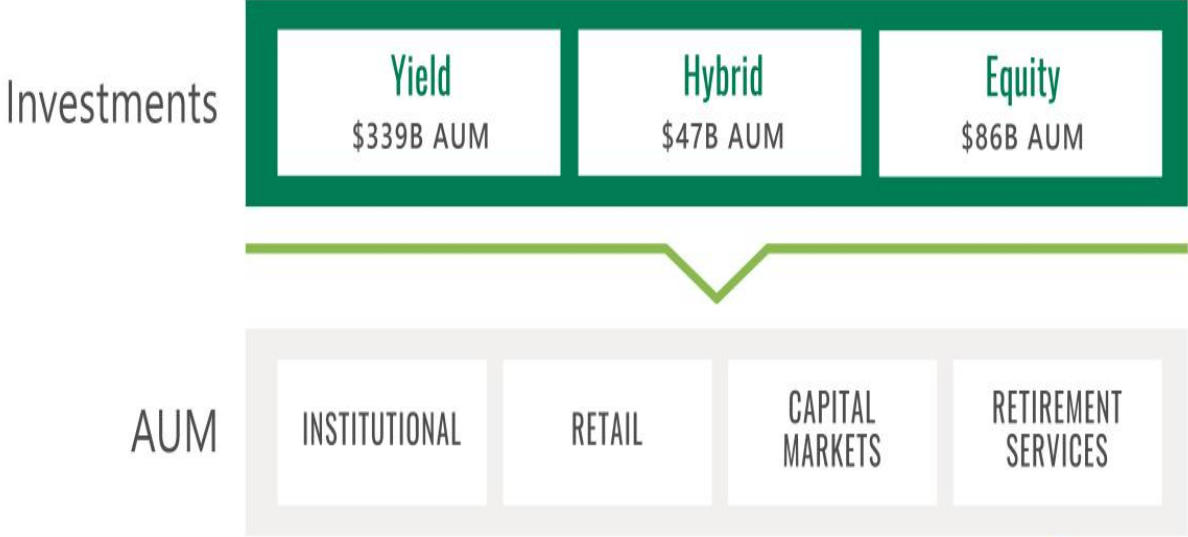

Also Raises AUM Through Institutional, Retail, and Capital Markets Channels

Note: AUM as of June 30, 2021.
APOLLO INVESTOR DAY 2021

Strong Secular Tailwinds...

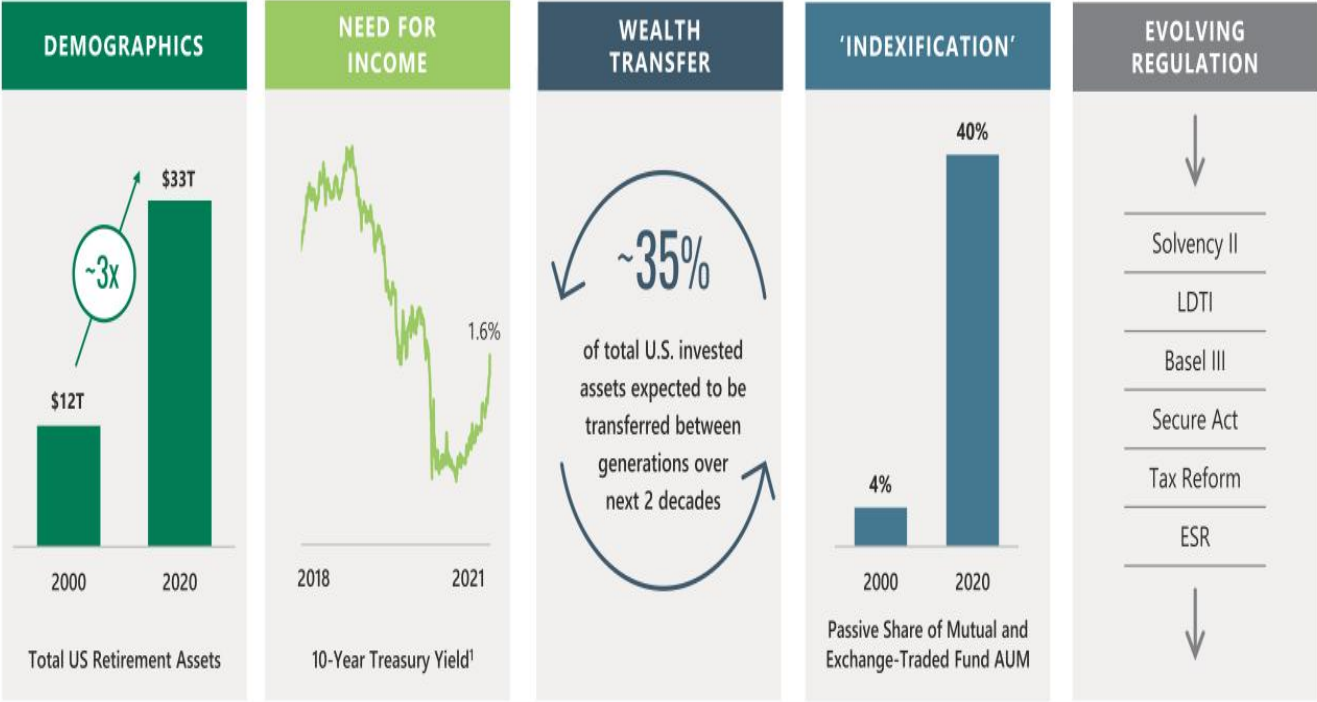

Sources: Investment Company Institute, Federal Reserve Economic Data, Accenture, Morningstar. 1. 10-Year Treasury yield as of October 15, 2021.
 APOLLO INVESTOR DAY 2021

...Drive Significant Growth in the Alternatives Industry

(\$ TRILLIONS)

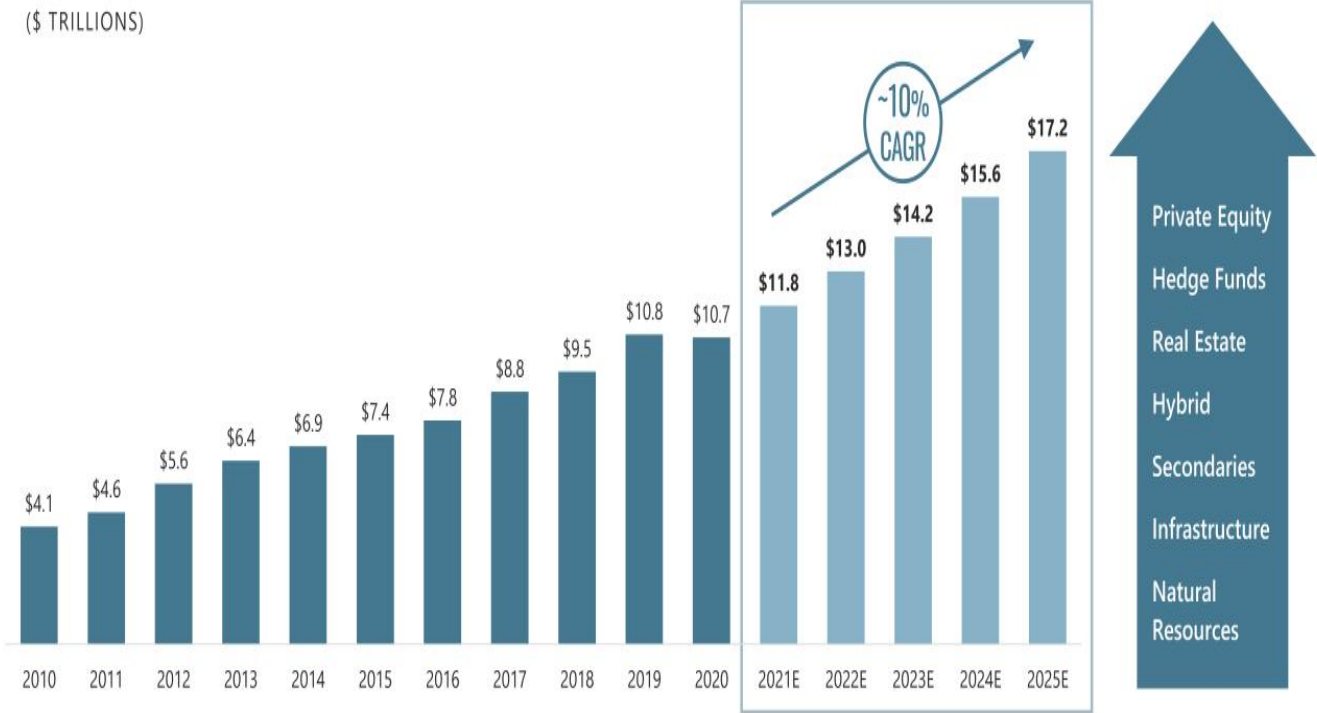

ALTERNATIVE INVESTMENTS AUM

Note: 2021-2025 are Preqin's forecasted figures. Sources: Preqin Future of Alternatives 2025, Asset Classes Data Pack.

Private Credit is Growing Rapidly Within the Alternatives Market

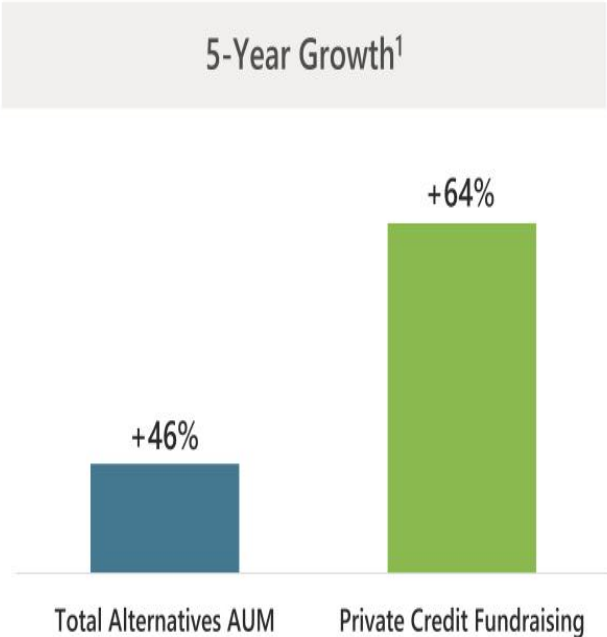

“ Private Credit Markets are Due for a Growth Spurt ”

– *The Economist*, April 2021

“ With Higher Yields Hard to Find Elsewhere, 2/3 of Investors Intend to Increase Investment in Private Credit ”

– *JPM Asset Management*, January 2021

Sources: Preqin, JP Morgan Guide to Alternatives. 1. From 2015-2020.
APOLLO INVESTOR DAY 2021

WHAT WE DO

We seek to provide **excess returns** to investors on a risk-adjusted basis

We serve a **growing market** driven by the need for retirement income

We Produce Excess Return Across the Risk Spectrum

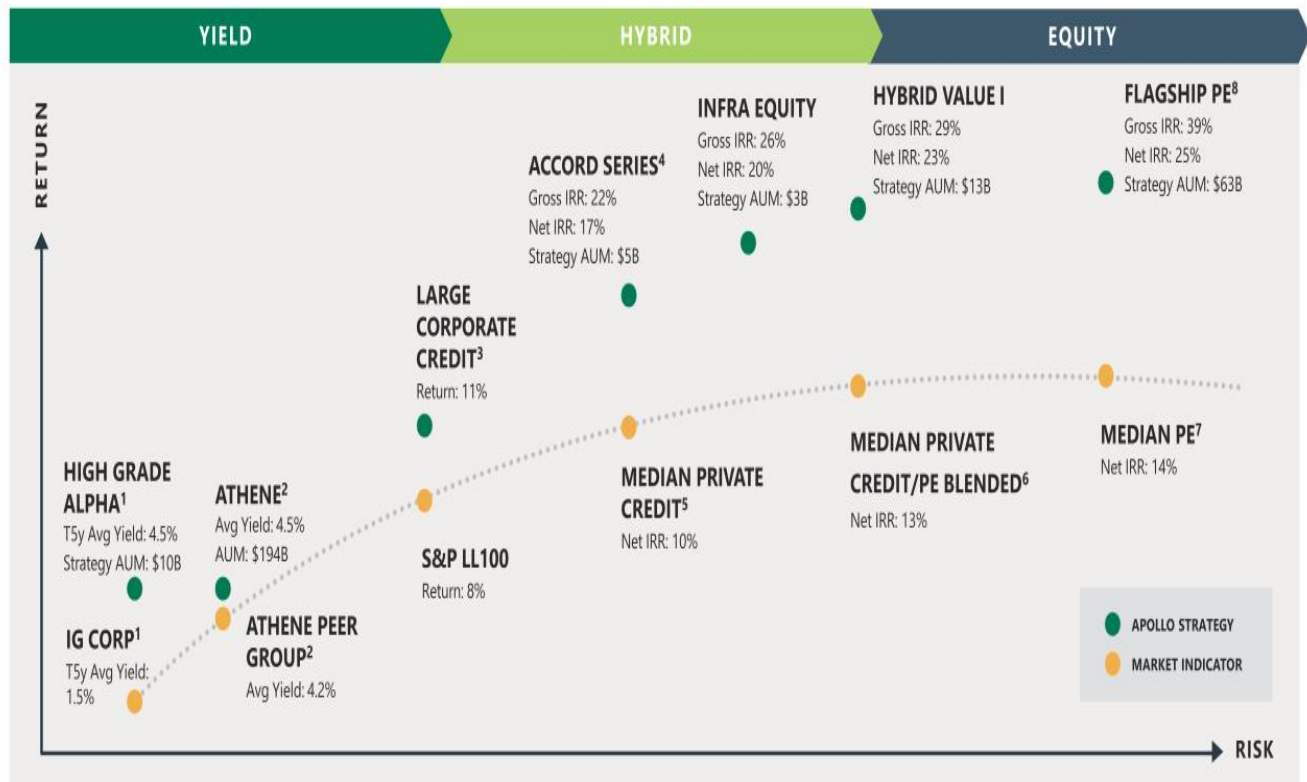

Note: Data as of June 30, 2021, unless otherwise noted. Not a comprehensive list of all Apollo funds and were chosen on the basis of illustrative mandates across the platform. Apollo Strategy and corresponding Market Indicator are not directly comparable. Actual results may vary and these returns may differ substantially from the strategies. There can be no guarantee or assurance that similar opportunities will become available, particularly on a direct basis, in the future or if available, that such opportunities will achieve target returns once realized. Additional information is available upon request. Past performance is not indicative of future results. Please see the Appendix for important information on index performance. IRR calculations based on Apollo calculations, not an industry standard. Footnote explanations may be found in presentation endnotes.

Our Flagship Products Have Meaningfully Outperformed

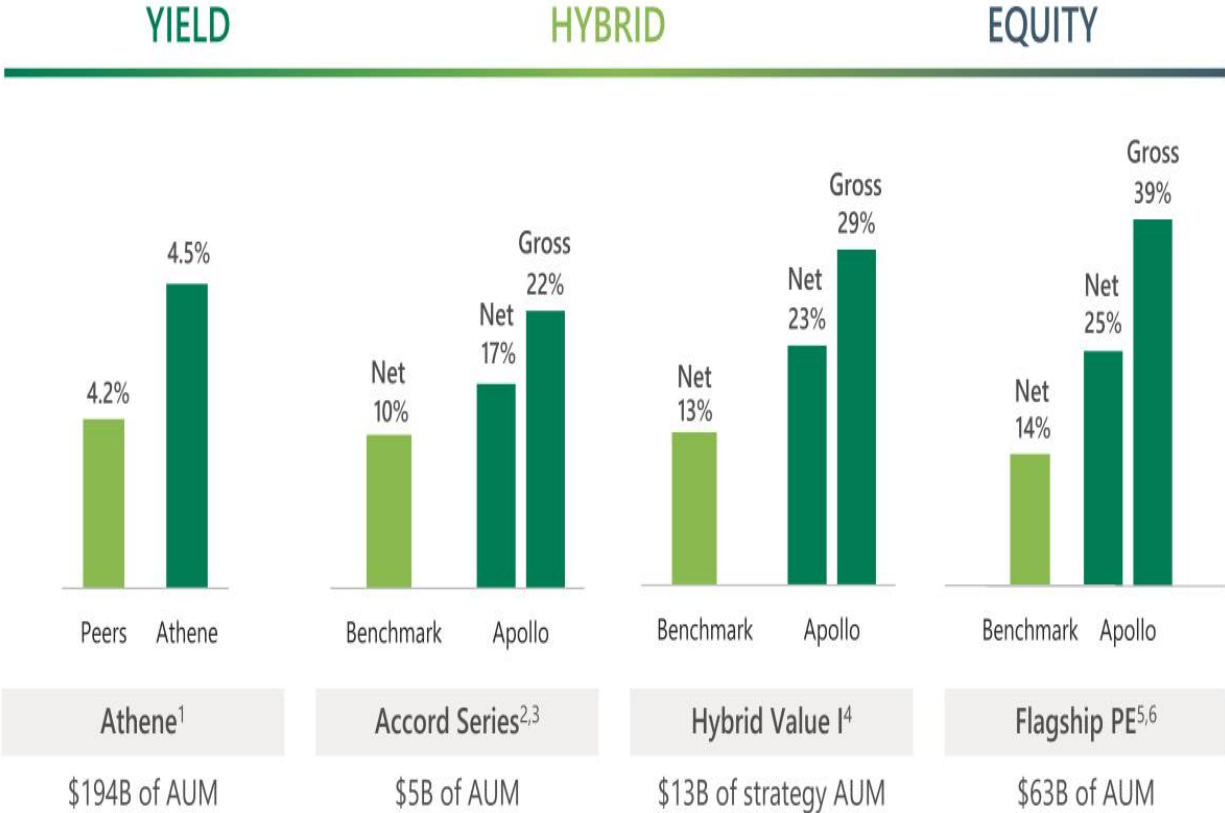

Note: Apollo AUM and performance data of June 30, 2021. Footnote explanations may be found in presentation endnotes.

Our Lens on the Landscape



The market is growing



Capital is plentiful



Historical performance
is strong

OUR PHILOSOPHY

Source good assets

Seek to deliver excess return

*AUM is the reward for success,
not the goal in itself*

Let Us Take You Through Our Playbook



We Seek to
Provide
Excess Returns



Our Business
is **Aligned**
to a Larger
Addressable
Market



Our Focus
is on **Scalable**
Businesses and
Large
Whitespace



We are
Building a
Recurring Asset
Origination
Machine

Goal to Reach \$1 Trillion AUM & More Than Double FRE Before Benefits of the Merger

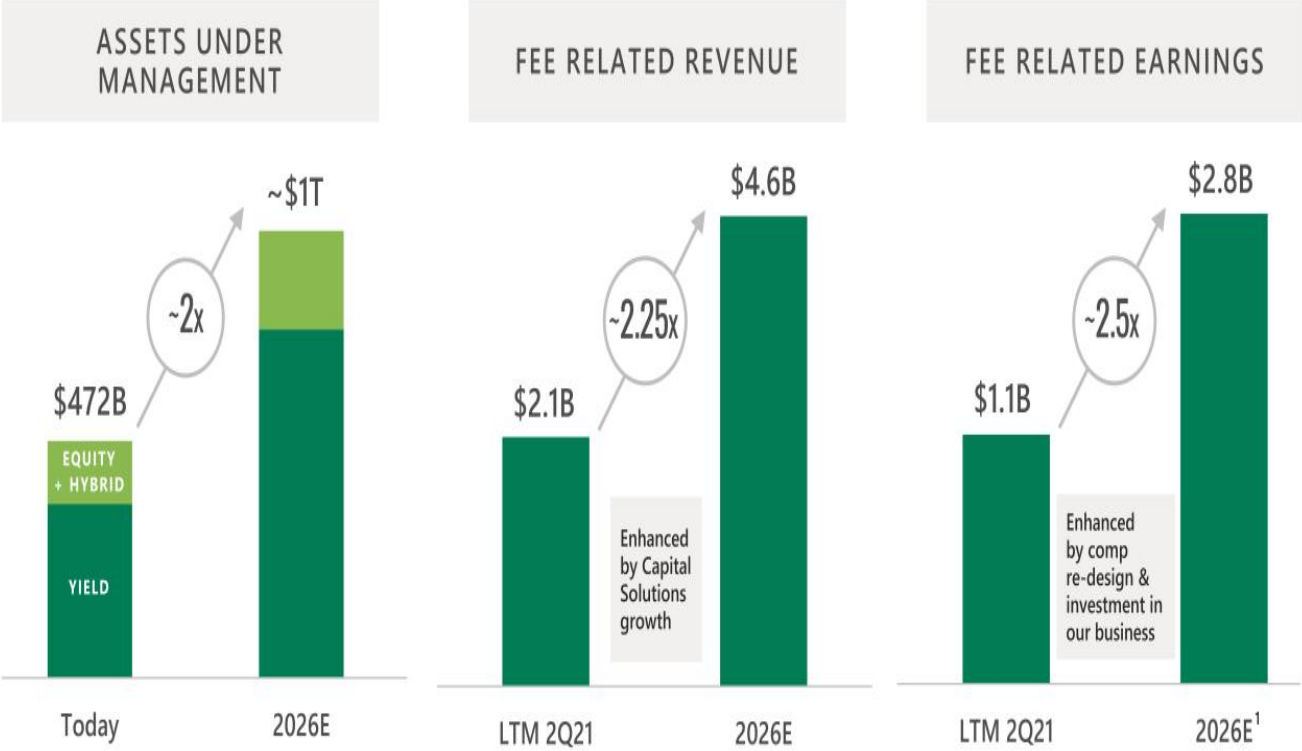

1. Reflects anticipated pro-forma allocation of expenses across segments.
 APOLLO INVESTOR DAY 2021

Continuing Leadership in the Equity Business

ASSETS UNDER MANAGEMENT

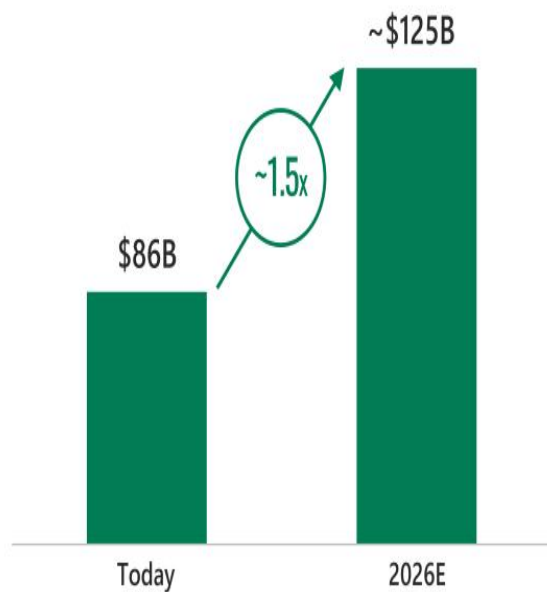

DRIVERS OF GROWTH

- Strong track record over long-term and short-term
- High conviction fundraising assumptions
- PE Fund X (expected launch in 2022)
- Filling in the whitespace – Impact, US & Asia Real Estate
- Important source of intellectual capital

Capturing the Whitespace with Our Hybrid Business

ASSETS UNDER MANAGEMENT



DRIVERS OF GROWTH

- Large voids in the financing markets
- Strong track record of delivering returns + structured to provide downside protection
- Numerous scaling franchises
- Conservative assumptions on fundraising and maturation of investor base

Generating Significant Growth in Our Yield Business

ASSETS UNDER MANAGEMENT

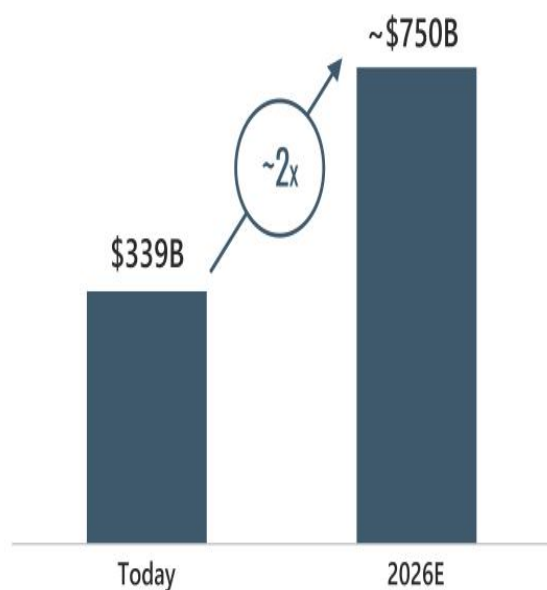

DRIVERS OF GROWTH

- Largest addressable market with strong underlying growth
- Strong returns in traditional private credit
- Fully-built ecosystem with \$80B running originations before growth
- Limited reliance on 3rd party fundraising

Scaling Production in Our Capital Solutions Business

FEE RELATED REVENUE

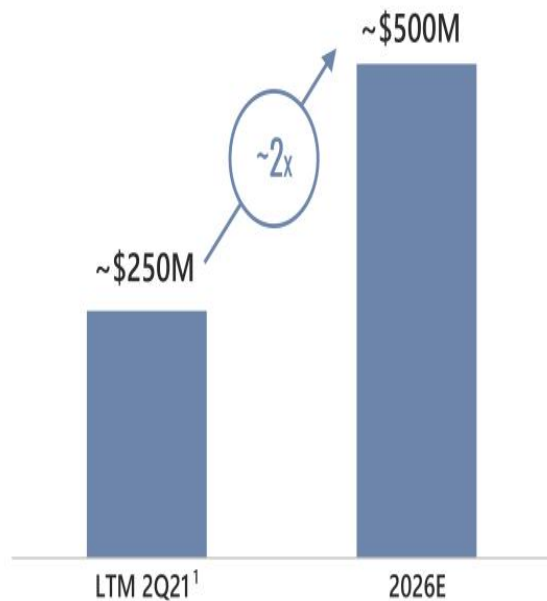

DRIVERS OF GROWTH

- Massive transaction flow today
- Strong network of relationships
- Underpenetrated today
- Synergistic growth with Equity, Hybrid, and Yield businesses

1. For presentation purposes, LTM 2Q21 fee related revenue from transaction and advisory fees excludes monitoring and miscellaneous fees from the private equity segment recognized over the same period.

Base Plan of 18% Compound Annual FRE Growth and Investment of ~\$5B of Capital, Before Embedded Options

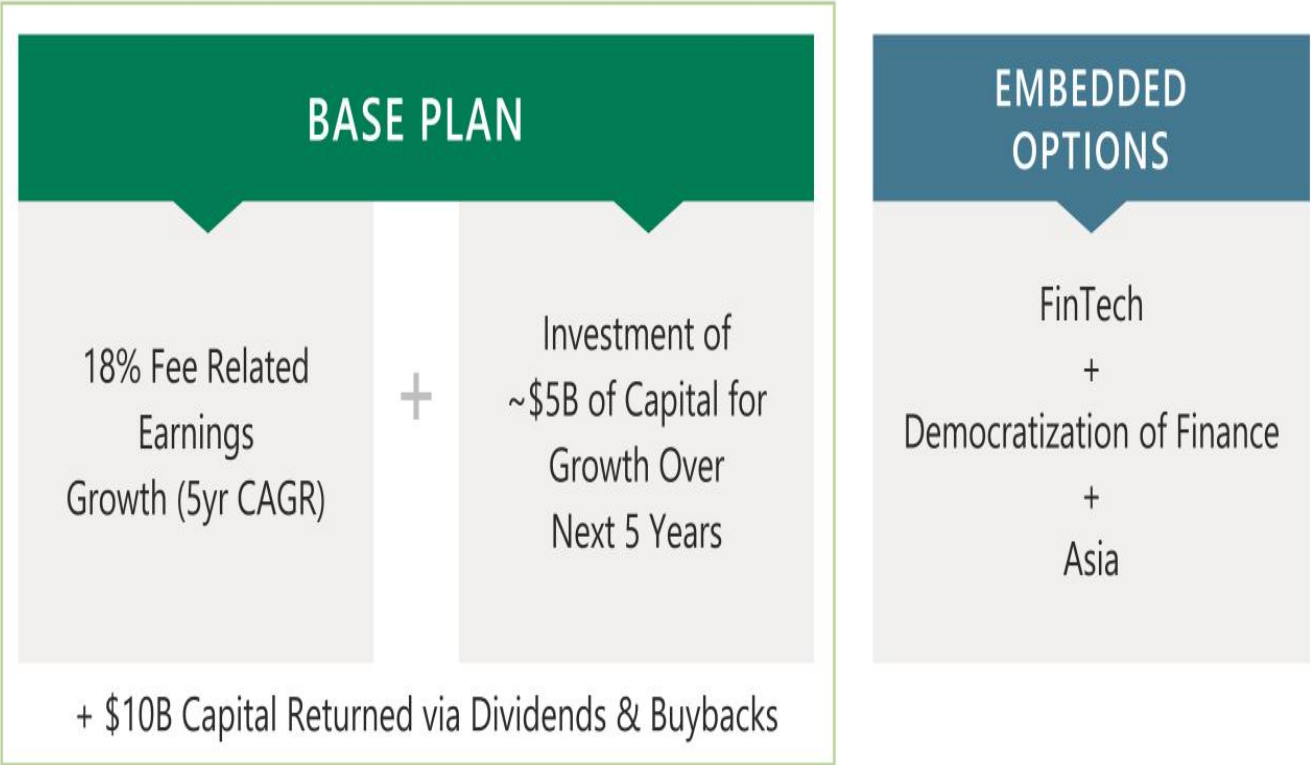

2

Largest Addressable Market Among Alternatives Peers

Our View of the Addressable Private Credit Market is Deeper

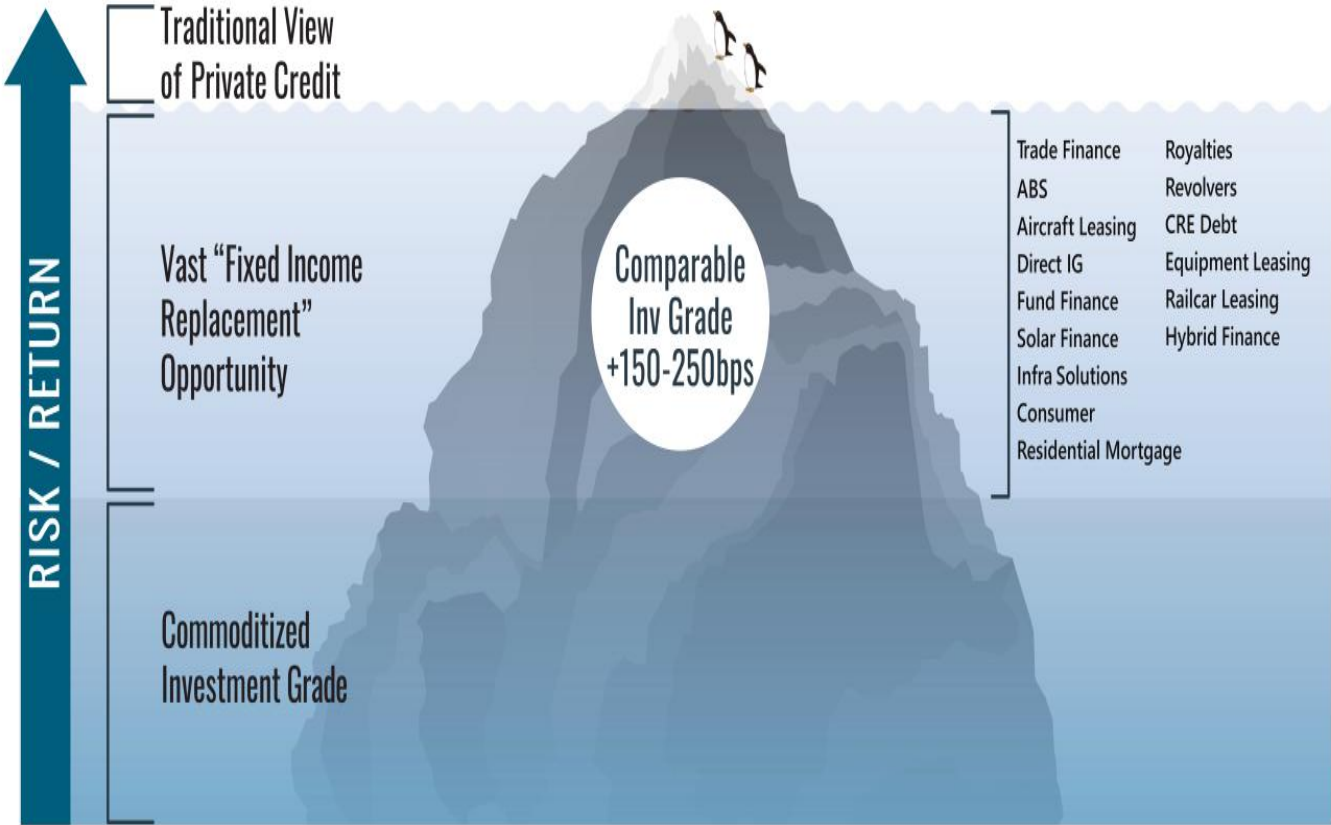

The Addressable Market for Fixed Income Replacement is Larger Than the Traditional Alternatives Market in its Entirety



Note: Alternative assets and private credit AUM based on forecasted Prequin data for 2021. Fixed income replacement market based on Apollo estimates. Sources: Apollo Chief Economist, Federal Reserve Board, S&P LCD, BofA, Prequin, SIFMA, Haver Analytics, Bloomberg.
APOLLO INVESTOR DAY 2021

Why Aren't Others Addressing the Vast Fixed Income Replacement Market?

BECAUSE THIS MARKET REQUIRES A COMPLETELY DIFFERENT ECOSYSTEM

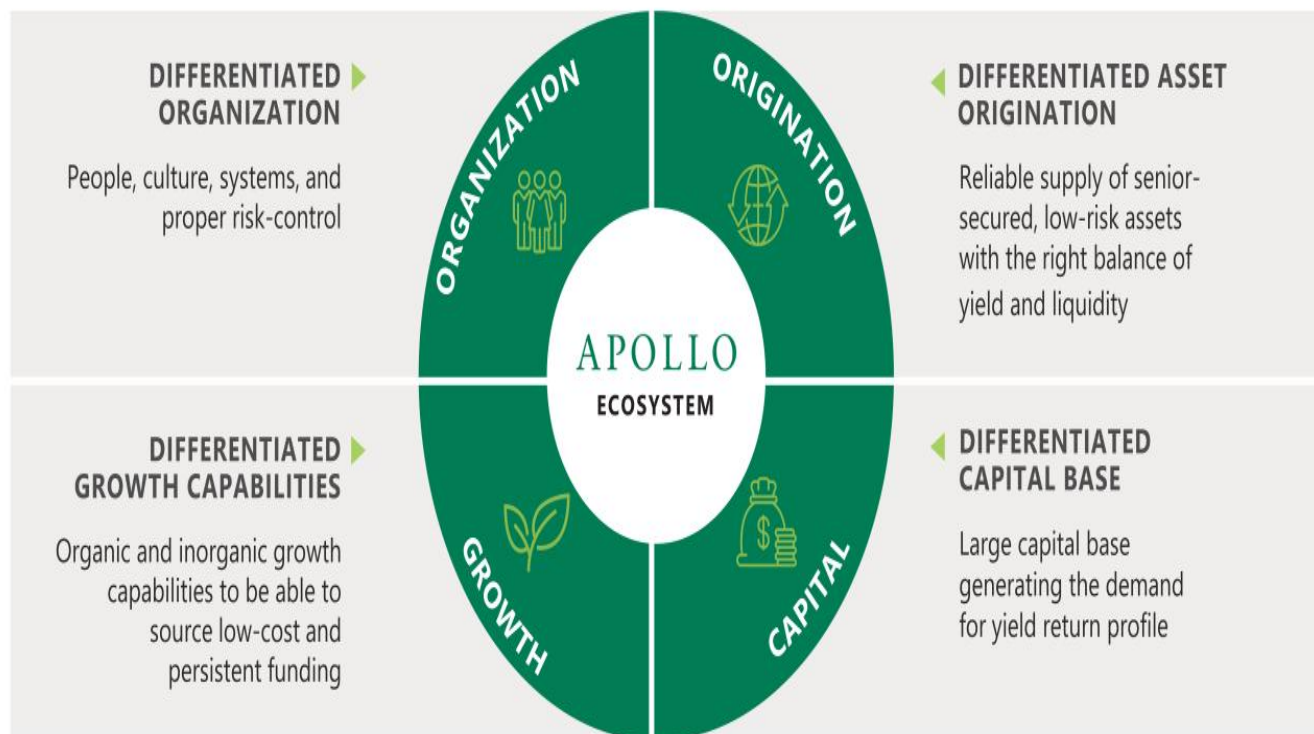

Differentiated Asset Origination: Building Reliable Supply

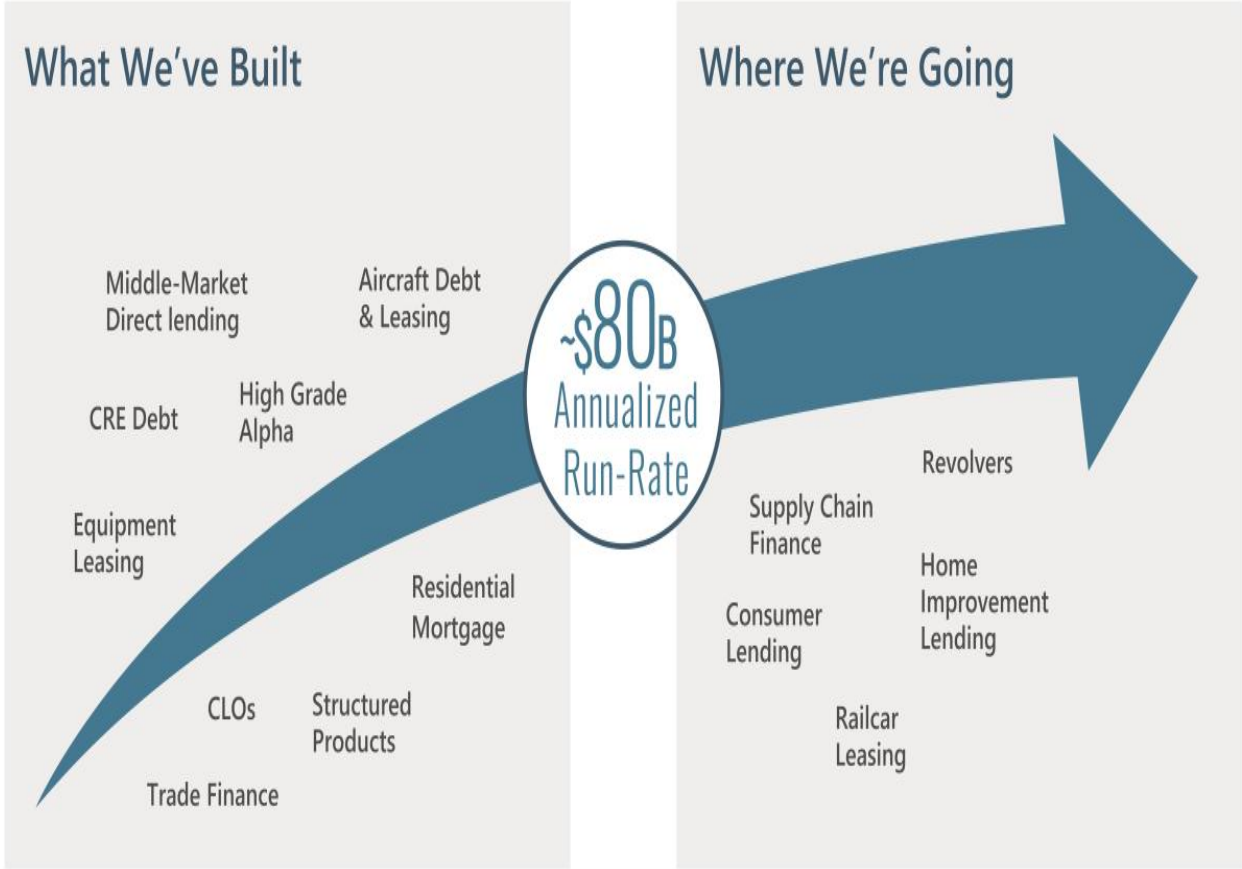

Note: Annualized run-rate of total yield asset origination as of June 30, 2021.

Differentiated Capital Base: Scale Matters



YIELD AUM ACROSS SELECT PEERS¹

Note: Data as of June 30, 2021. Peer group meant to be representative, not exhaustive. 1. Peers represented estimated credit and insurance AUM based on public disclosure.

Differentiated Growth: Organic Inflows of Low-Cost Capital

ATHENE ORGANIC INFLOWS (\$B)

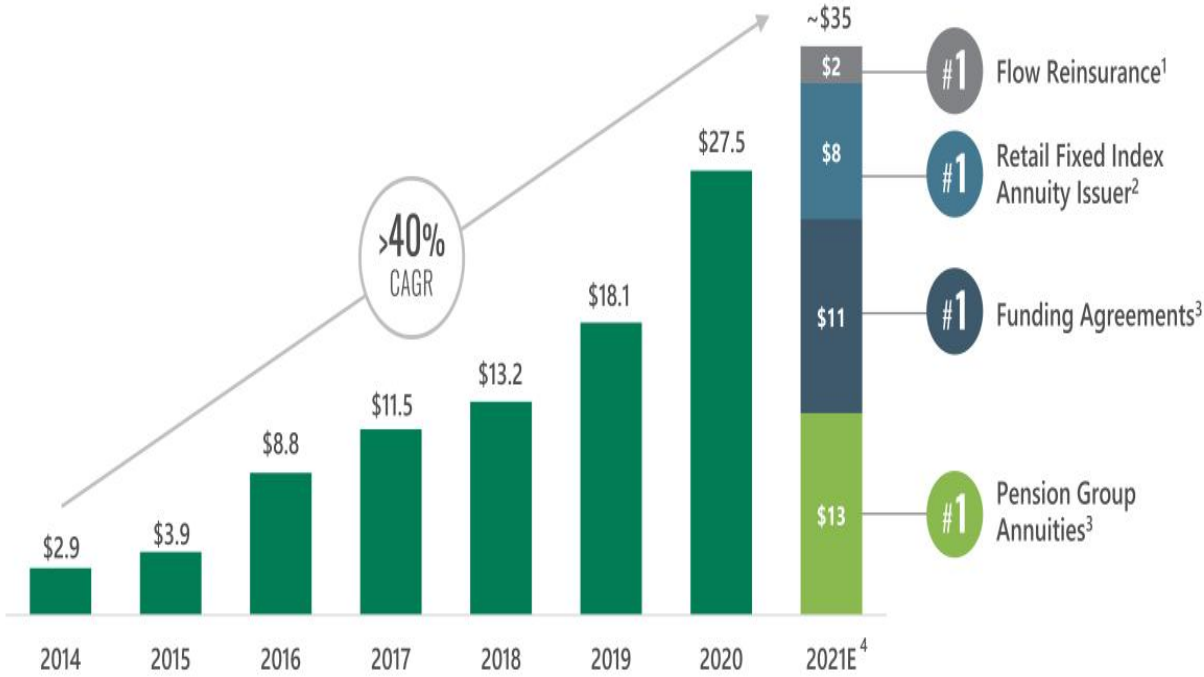

Note: Numbers may not sum due to rounding. Gross inflows based on Athene public disclosure. 1. #1 US annuity flow market share in 2020 per US Public BlueBook Filings from Cedents. 2. LIMRA data for the six months ended June 30, 2021. 3. For the six months ended June 30, 2021. 4. Forecasted organic inflows by channel, subject to change.

Apollo Serves the Alternatives Sector and the Large and Growing Fixed Income Replacement Market

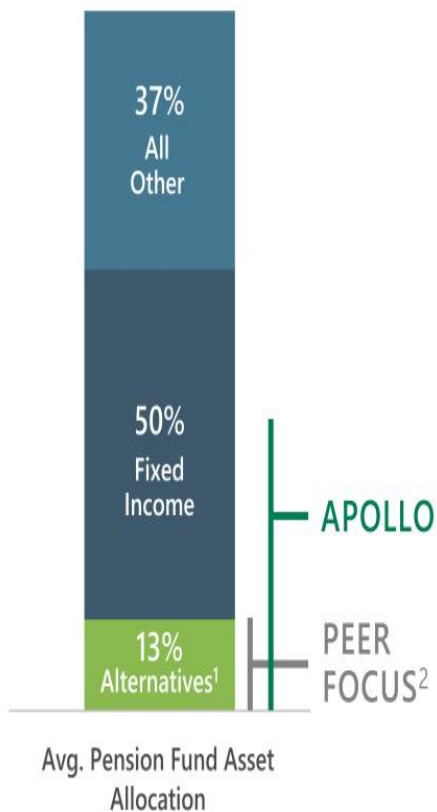

- Both markets are **very large**
- Both markets are **growing**
- Both markets offer ability for **excess return**
- Both markets pay **higher fees for excess return**

Source: Willis Towers Watson Report as of 2020. 1. Includes private equity, hedge funds, real estate, alternative and miscellaneous asset classes. 2. Illustrative of business focus of other alternative asset managers.
APOLLO INVESTOR DAY 2021

Differentiated Growth: Large and Growing 3rd Party Yield Business

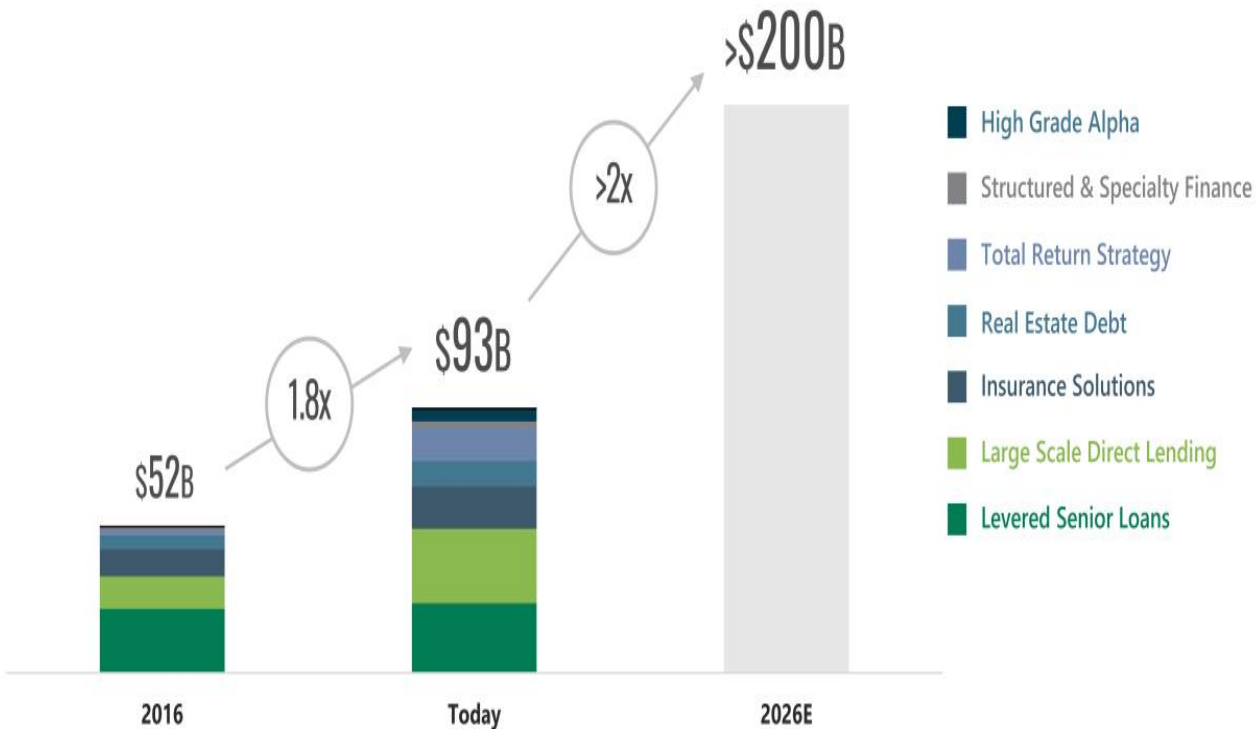

Note: Figures reflect third-party AUM in yield business.
 APOLLO INVESTOR DAY 2021

Differentiated Organization

THE APOLLO ECOSYSTEM IS TEEMING WITH DEDICATED RESOURCES FULLY DEVOTED TO SOURCING YIELD



Note: Data as of June 30, 2021. 1. Origination platform employees are not Apollo employees.
APOLLO INVESTOR DAY 2021

Why Do We Like This Market?

- ✓ Large market size
- ✓ Ability to generate excess returns
- ✓ Permanent recurring origination
- ✓ Less cyclical
- ✓ More easily scalable
- ✓ Different competitors
- ✓ Requires a completely differentiated ecosystem

Note: Please refer to the Definitions pages at the end of this presentation for the definition of permanent.

3

Athene is a Competitive Differentiator
and Growth Accelerant

Athene's Balance Sheet is Simple and Straightforward

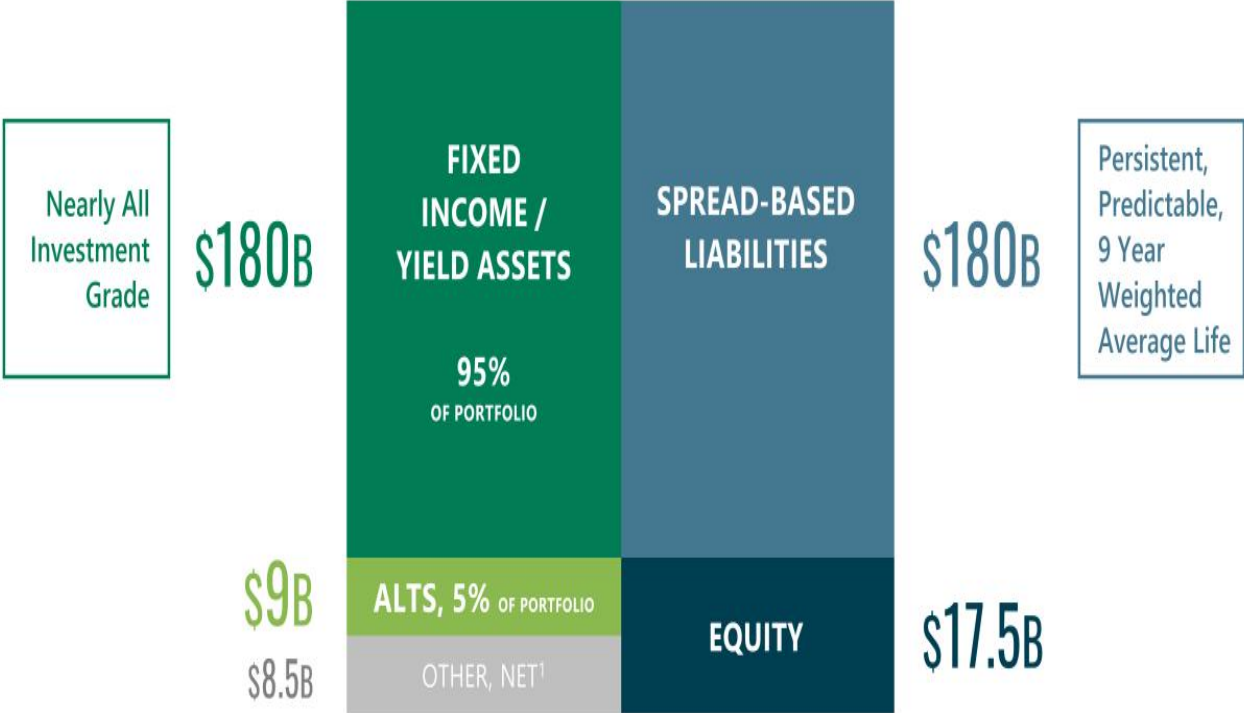

Note: Data as of June 30, 2021. Spread liabilities equal to gross reserve liabilities. Equity equal to adjusted AHL common shareholders' equity, ACRA non-controlling interest, and preferred equity. 1. Other, net includes all other assets as defined by GAAP excluding gross invested fixed income and alternative assets, less other liabilities including debt and accumulated other comprehensive income.

Athene Has a Simple, Spread-Based Business Model

STRONG TRACK RECORD OF PROFITABILITY & OUTPERFORMANCE

	TODAY (Recent New Business, 1H21)	TRAILING 3YR (3Q18-2Q21)	
Asset Yield	3.49%	4.38%	~30bps better vs others, net of fees ¹
Cost of Funds	2.24%	2.77%	Disciplined and dynamic pricing
Opex & Taxes	0.22%	0.48%	~30bps more efficient OpEx vs others ²
Net Spread on Assets	1.03%	1.13%³	
Implied ROE⁴		~15%	~300bps better vs others⁵

Note: Industry comparison noted as "others" represent a weighted average of AEL, AIG, AFG, FGL, LNC, MET, PRU, and PFG for the 5 years 2016 to 2020. Source: SNL Financial, Company Filings. Footnote explanations may be found in presentation endnotes.

Athene is Uniquely Positioned in the Industry

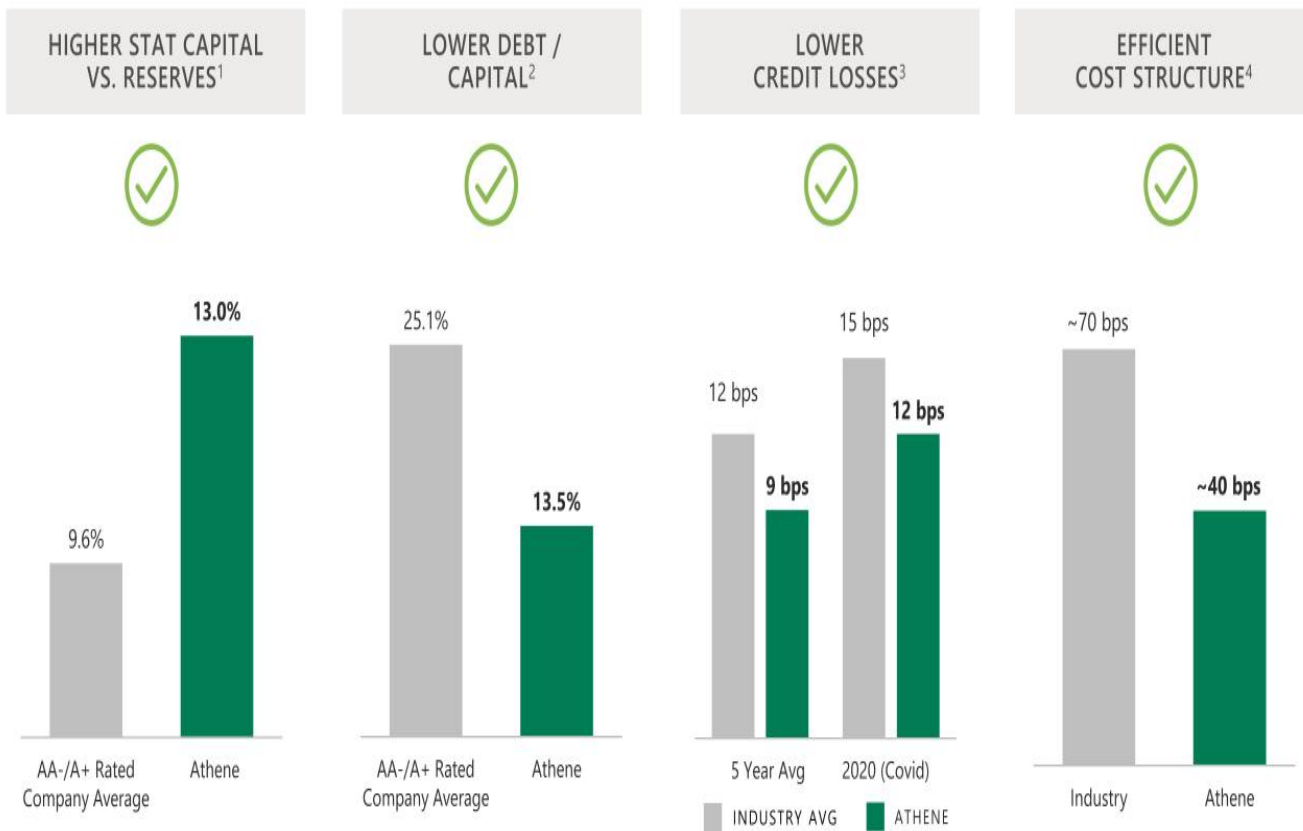

Footnote explanations may be found in presentation endnotes.

Athene's Substantial Available Capital = Embedded Growth

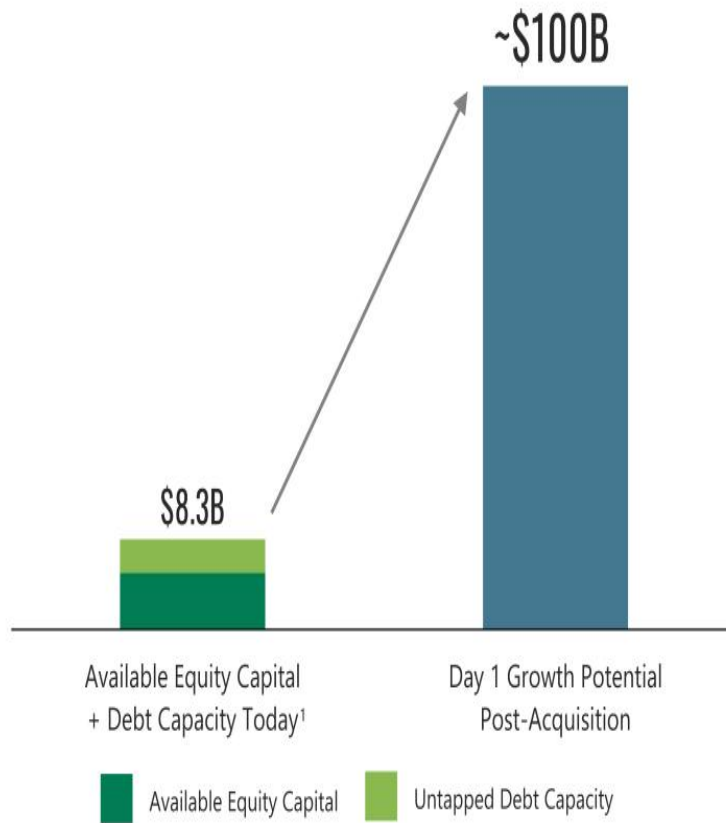

1. For Athene, available equity capital (inclusive of excess capital and uncommitted capital in ADIP) and debt capacity as of June 30, 2021.

Athene Has Generated Compelling Returns Over Time

ADJ. OPERATING ROE¹

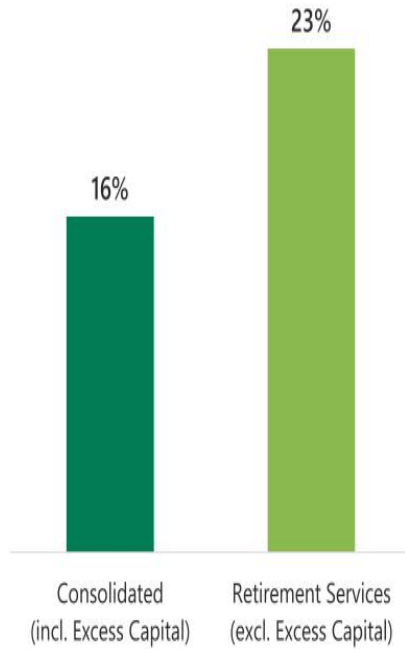

ADJ. BOOK VALUE GROWTH²

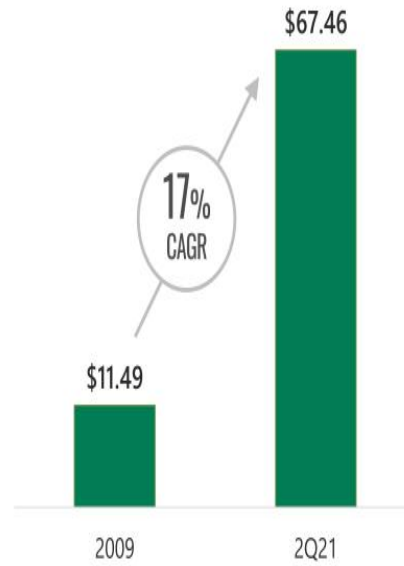

Note: Data as of June 30, 2021, unless otherwise stated. 1. Long-term average over 2014-2021 excluding AOG. 2. Adjusted book value per ATH common share.

APOLLO INVESTOR DAY 2021

High Returns Attract Third-Party Capital to Finance Growth

IN 2019, WE FORMED AN INNOVATIVE SIDECAR TO SUPPORT ATHENE'S CONTINUED GROWTH

APOLLO/ATHENE DEDICATED INVESTMENT PROGRAM (ADIP)

- ✓ First sidecar in the industry
- ✓ Direct equity capital to support Athene's growth
- ✓ No dilution to shareholders
- ✓ Greater 3rd party participation & capital efficiency for future sidecars

\$3.2B Capital Raised

\$1.7B Deployed To-Date

Target Mid-Teens Net IRR to LPs

ADIP is an Innovative Tool Which Drives Greater Capital Efficiency

% OF ANNUAL GROWTH ATHENE SUPPORTS WITH ITS OWN CAPITAL

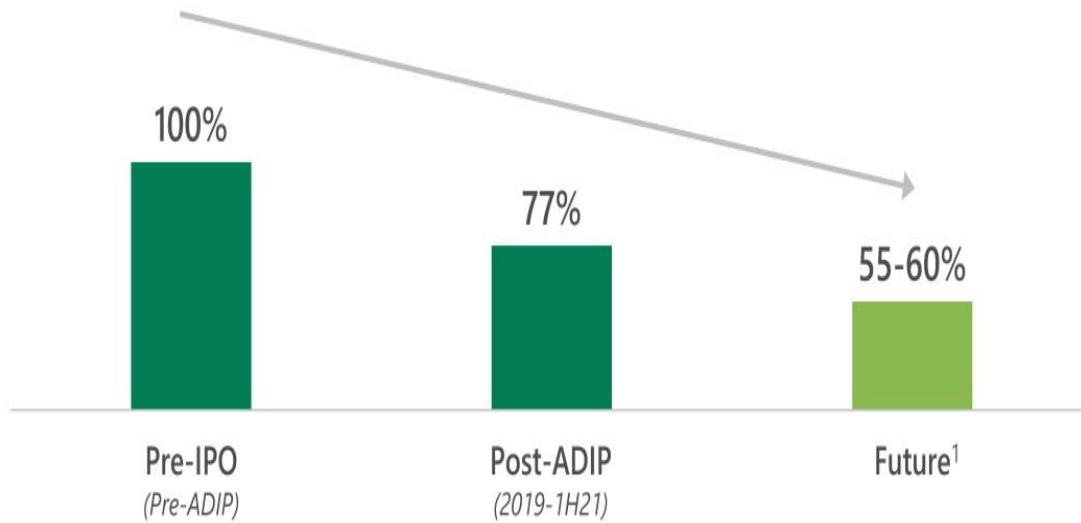

We anticipate Athene will be increasingly capital efficient going forward

1. Based upon current 5-year projections and estimates.

What Do You Need to Understand About This Business?



Why Own 100% of Athene and Change the Status Quo?

THIS IS TABLE STAKES, THERE'S NOTHING MORE STRATEGIC

Control over

~\$35B

of annual inflows

Control over
asset origination
with combined

\$80B

run-rate
originations

Capture attractive spread
earnings, which we
anticipate will amount to

~\$13B

pre-tax cumulative
over 5 years

Strategic Alts capacity,
which we anticipate
will double to

~\$20B

over
5 years

Strategic Importance of Athene's Investment Portfolio

ATHENE'S PORTFOLIO IS A HOME FOR STRATEGICALLY IMPORTANT DEBT AND EQUITY INVESTMENTS

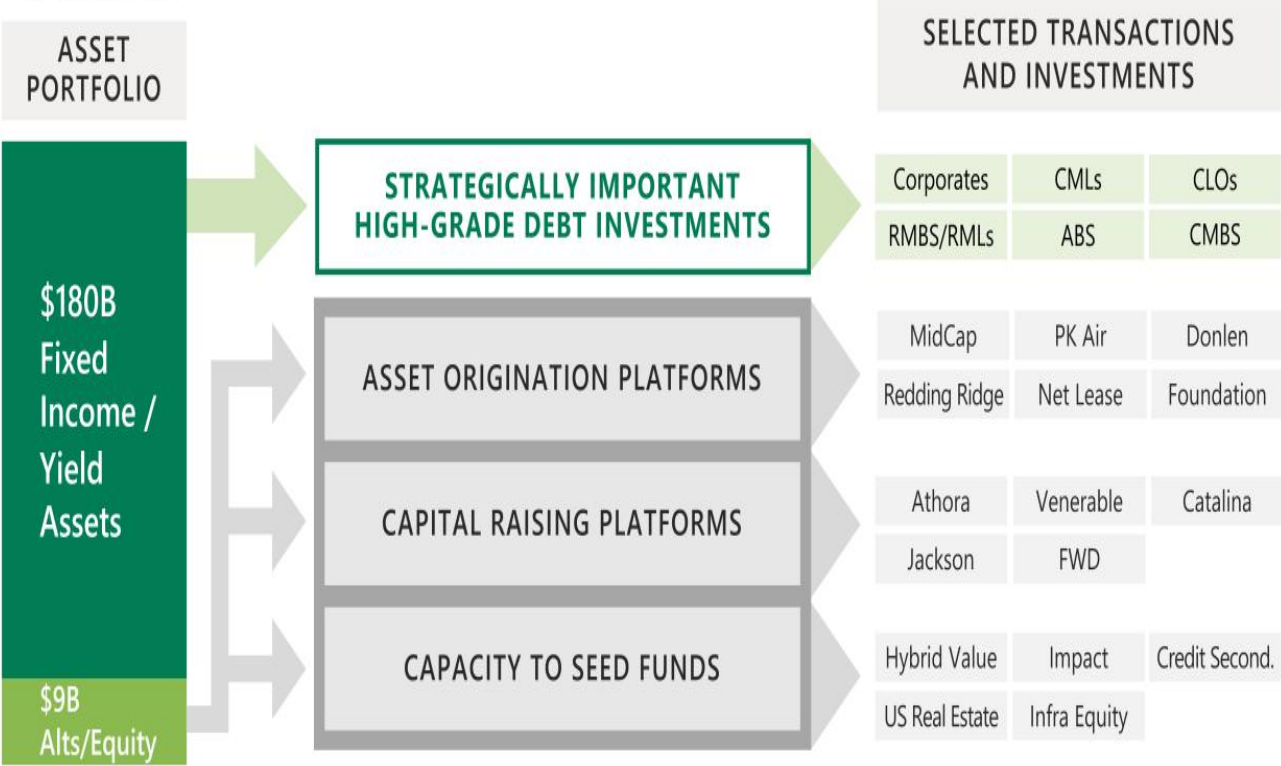

Note: Represents Athene gross invested assets as of June 30, 2021, presented on a GAAP basis. Transaction with FWD has not closed and may never close.

100% Alignment Accelerates Growth

ATHENE HAS SUPPORTED / SEEDED APOLLO STRATEGIES THAT HAVE SCALED TREMENDOUSLY

WITH MORE WIN-WIN OPPORTUNITIES ON THE HORIZON

Products Seeded by Athene	Third-Party AUM	Run-Rate Third-Party FRE Revenue
Funds	~\$14B	~\$72M
Platforms	~\$87B	~\$186M
Products	~\$16B	~\$68M
	~\$117B	~\$326M



New Platforms

Consumer Revolvers Railcar
Supply Chain Home Improvement

New Funds & Products

Growth GP Solutions
Energy Transition FinTech

Capital Solutions

Asia

Japan Asia ex-Japan Australia

FWD **challenger**

Note: Run-rate based on June 30, 2021 AUM. There is no assurance that run-rate FRE revenue will be achieved.

Highly Efficient Model

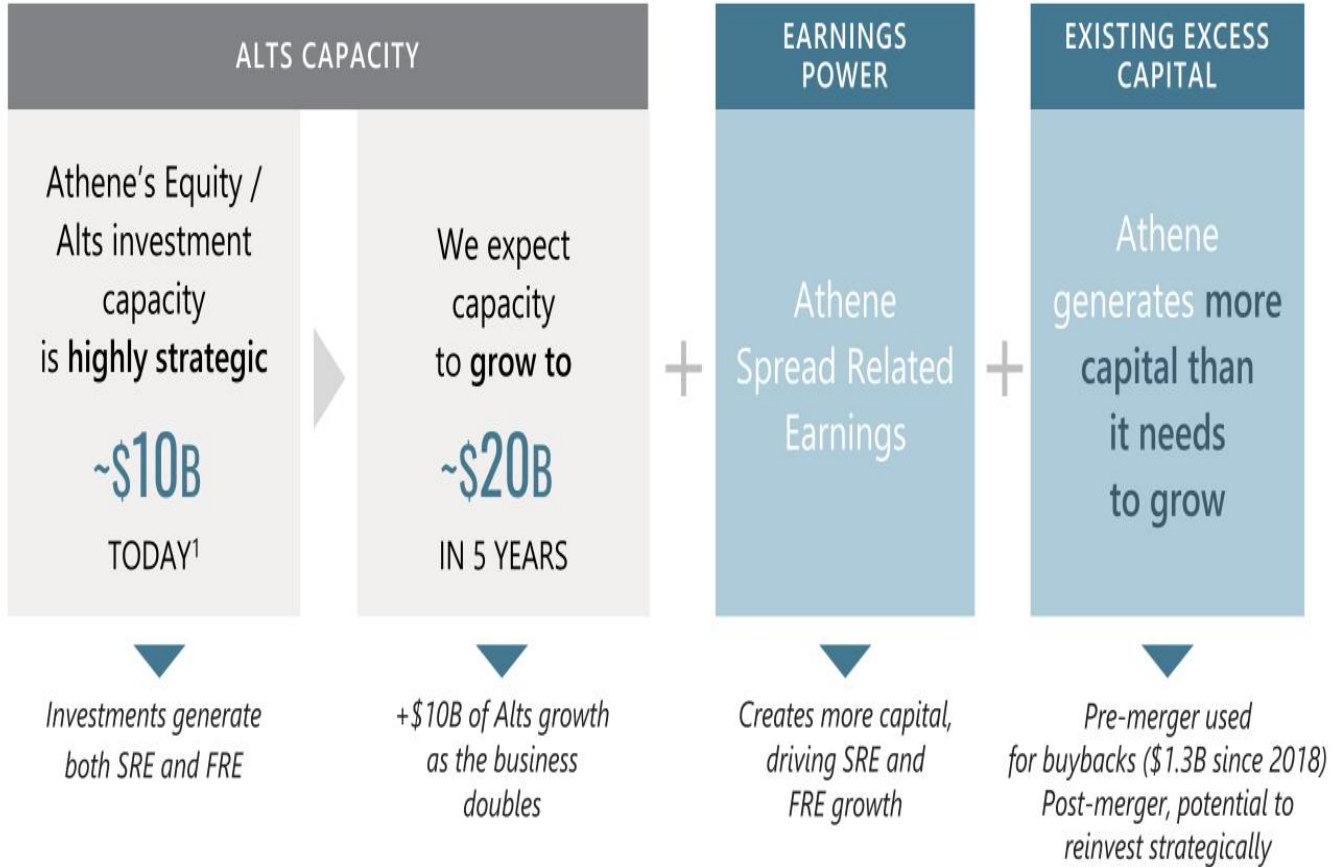

1. Post-merger, expect to transfer approximately \$800M of alternatives from Apollo balance sheet into Athene's alternatives portfolio.
APOLLO INVESTOR DAY 2021

Athene Represents a Strategic Purchase for Apollo

	AT ANNOUNCEMENT 2021E	CURRENT 2022E
Apollo Issues Shares in Merger	166M	166M
Apollo Share Price ¹	x \$49.56	x \$67.42
Apollo Stock Issuance, gross	\$8.2B	\$11.2B
Apollo Equity Held by Athene	(\$1.4B)	(\$1.7B)
Apollo Stock Issuance, net	\$6.8B	\$9.5B
Consolidate 100% ² of Athene Recurring Spread Related Earnings	÷ \$1.4B ³	÷ \$1.7B ⁴
IMPLIED ACQUISITION P/E MULTIPLE	5.0X²	5.6X²

Footnote explanations may be found in presentation endnotes.

APOLLO INVESTOR DAY 2021

53

Non-Traded BDC and REIT Growth Has Been Explosive

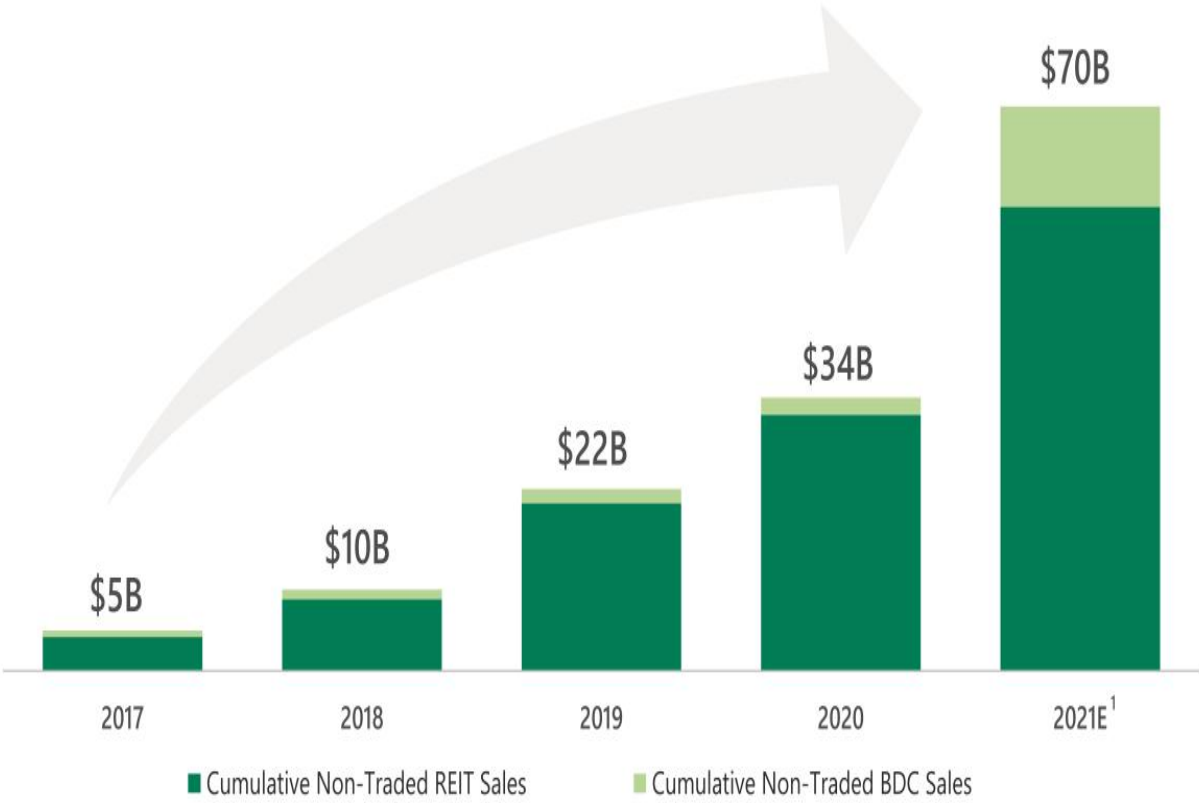

Source: Robert A. Stanger & Co. Inc. 1. Includes annualized 2021 sales. Non-Traded REIT sales through May 30, 2021. Non-Traded BDC sales through June 30, 2021.

Non-Traded BDC and REIT Earnings Model

INCENTIVE STRUCTURE

RETAIN 12.5% OF UPSIDE
OVER 5.0% HURDLE

TO CLEAR THIS HURDLE,
RISKIER INVESTMENTS
ARE REQUIRED



SAMPLE INVESTMENTS

Sub-Investment
Grade



Fiber
Companies



Middle Market
Loans



Shopping
Malls



The Market Values These Earnings Streams at High Multiples

BDC/REIT DRIVEN MANAGEMENT & INCENTIVE FEES WITHIN FRE

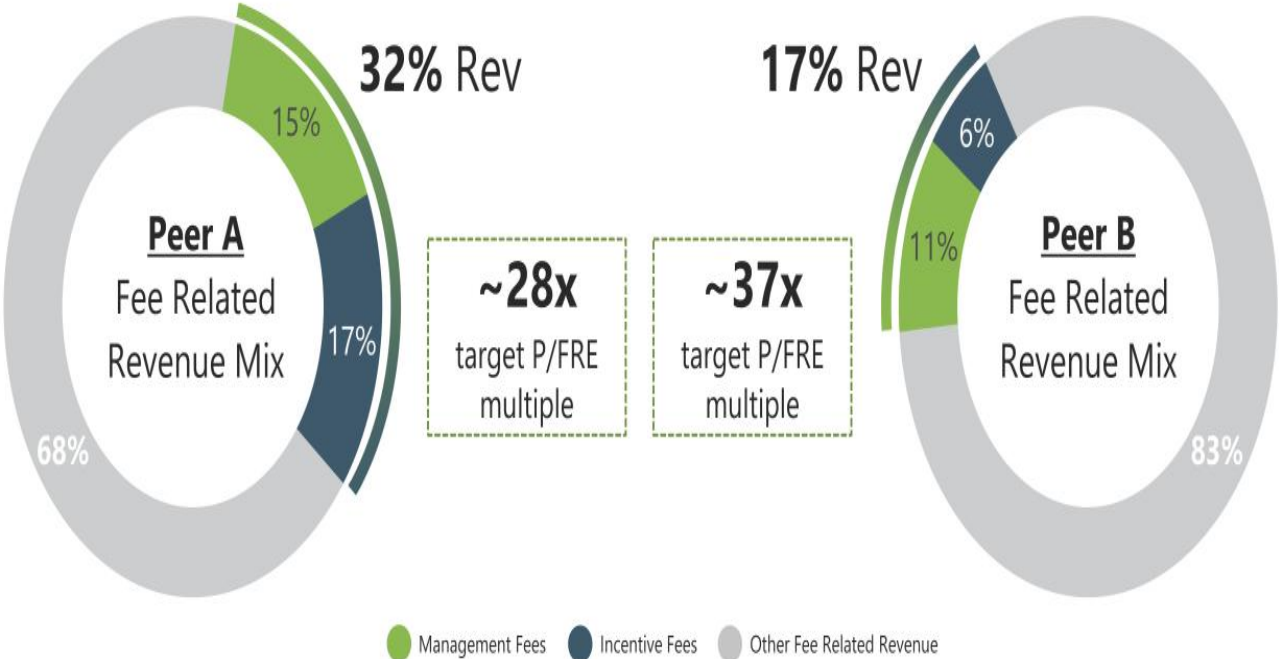

Note: Represents LTM fee revenue as of June 30, 2021. FRE multiples based on average P/E multiples on 2022E used across sell-side valuation frameworks from KBW, Goldman Sachs, and Citi.

Retirement Services Earnings Model

EARNINGS MODEL



SAMPLE INVESTMENTS

A-Rated
Bonds



Asset-Backed
Securities



First
Mortgages



Senior
Corporate Debt



1. As of June 30, 2021 94% of AFS securities designated NAIC 1 or 2.

We Believe Retirement Services is a Superior Model

	NON-TRADED BDC / REIT MODEL	RETIREMENT SERVICES MODEL	
<i>Portfolio</i>	Non-Investment Grade Assets	Investment Grade Assets	<input checked="" type="checkbox"/>
<i>Hurdle</i>	5-8% Hurdle	~2.5% Cost of Funds	<input checked="" type="checkbox"/>
<i>High Water Mark?</i>	Yes, Driving Volatility	None	<input checked="" type="checkbox"/>
<i>Profitability</i>	Cyclical	All Weather	<input checked="" type="checkbox"/>
<i>Marks</i>	Marked-to-Market	Held at Cost	<input checked="" type="checkbox"/>
<i>Liquidity</i>	Periodic Liquidity	None	<input checked="" type="checkbox"/>
<i>Basis of Fees</i>	Equity	Assets	<input checked="" type="checkbox"/>
<i>Capital</i>	0% Co-invest Today	8% Co-Invest	

We Like All Three, But We Have More of What We Like The Most

\$1 OF COMMINGLED FUND CAPITAL
Fundraising treadmill, but generally good for high return products
Carry not valued by the market
Capture management fee or 20% of upside
~3% coinvest
Riskier, limited applicability
Mid-teens growth

VS.

\$1 OF PRIVATE BDC/REIT CAPITAL
Permanent capital with periodic liquidity
Carry is fully-valued by the market
Earn management fee and 12.5% of upside
0% co-invest (today)
Cyclical performance
High-teens growth

VS.

\$1 OF RETIREMENT SERVICES CAPITAL
Permanent capital ¹
Upside is undervalued by the market
Earn management fee and keep 100% of upside
8% co-invest
Reliable earnings stream
Mid-teens growth forecasted

1. Please refer to the Definitions pages at the end of this presentation for the definition of permanent capital.

SRE is Recurring, Predictable, and Sustainable Through the Cycle

SPREAD RELATED EARNINGS¹

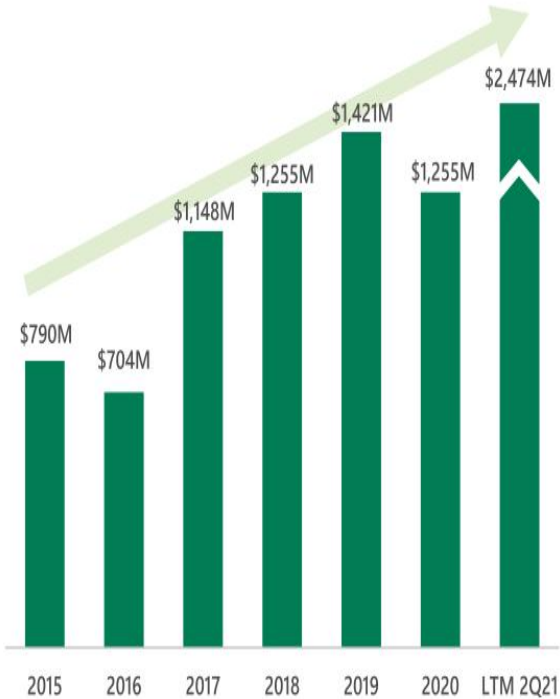

NORMALIZED SPREAD RELATED EARNINGS²



1. As reported by Athene, represents adjusted operating income with alternatives marked-to-market (excluding AOG investment, taxes and long-term incentive plan). 2. As reported by Athene, represents adjusted operating income (excludes AOG investment, taxes, and long-term incentive plan compensation) and reflects 11% long-term alternative investment returns.

Spread Earnings Significantly Undervalued

SPREAD EARNINGS (SRE)

Investment Grade Assets
Held at Cost / Less Impaired
No High Water Mark
Franchise Stability Through Cycle
"All Weather" Profitability
Mid-teens growth, 8% Capital

7-8x P/E Multiple

Analyst Consensus Valuation

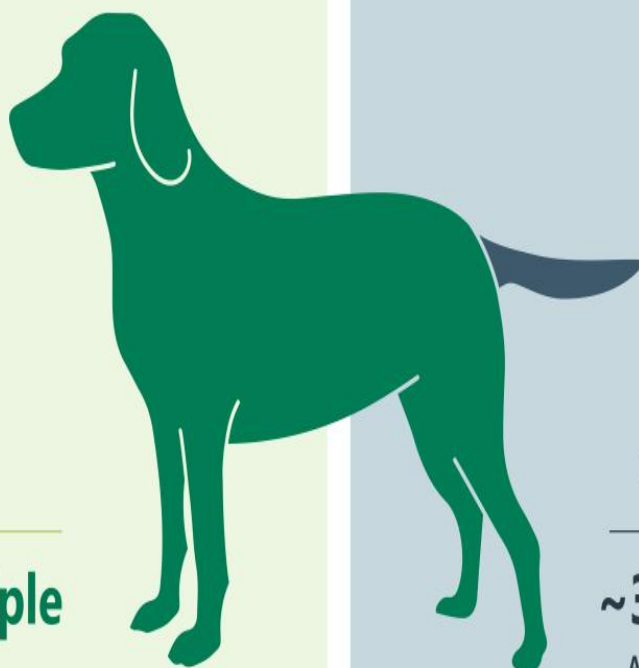

BDC/REIT INCENTIVE FEES

Non-Investment Grade Assets
5-8% Hurdle
Volatility over High Water-Mark
Cyclical Risk of Franchise Impairment
Potential Interest Rate-Driven
Earnings Volatility
High-Teens Growth, No Capital Today

~33x P/E Multiple

Analyst Consensus for BDC/REIT Incentive Fees within Fee Related Earnings

Note: FRE multiples based on average P/E multiples on 2022E used across sell-side valuation frameworks for Blackstone and Ares from KBW, Goldman Sachs, and Citi. SRE multiple based on sell-side analyst SOTP valuation.

APOLLO INVESTOR DAY 2021

4

Our Model Is Highly
Capital Efficient

Substantial, Visible Earnings Growth

BEFORE INVESTMENT OF ~\$5B OF CAPITAL GENERATED, ONE OF THE KEY BENEFITS OF MERGER, AND UPSIDE OPTIONS

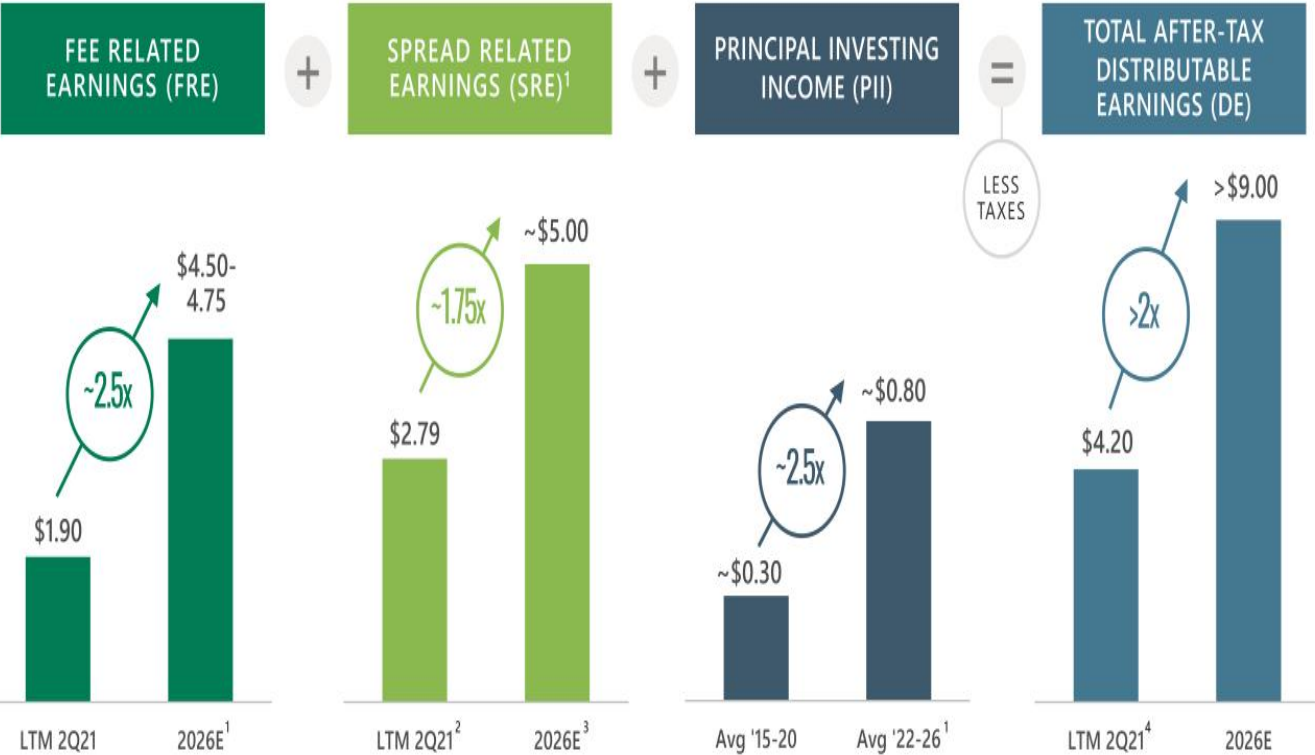

Note: Pro-forma for post merger share count of approximately 600mm shares, including anticipated equity awards related to compensation reset. 1. Reflects anticipated pro-forma allocation of expenses across segments. 2. Normalized earnings – see Appendix for more detail. 3. Includes estimated purchase accounting benefits. 4. Pro-forma for post merger share count of approximately 600mm shares, including anticipated equity awards related to compensation reset, and assumed tax rate of 18%.

Base Plan of 18% Compound Annual FRE Growth and Investment of ~\$5B of Capital, Before Embedded Options

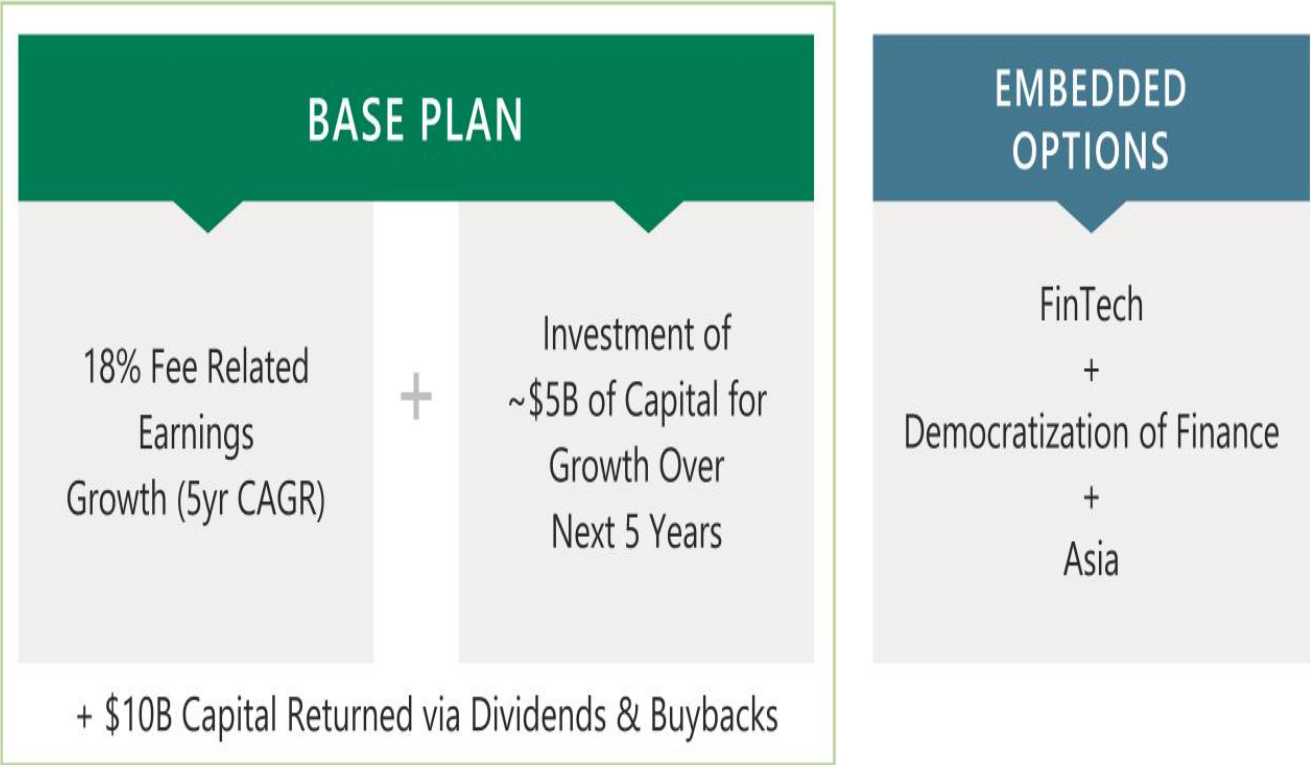

Projected to Generate Massive Capital

APOLLO

Growth
Engine



ILLUSTRATIVE
CAPITAL SPLIT...

~\$5
BILLION

\$1.60
**Base
Dividend**

~\$5
BILLION

for
**Additional
Capital Return**

~\$5
BILLION

for
Growth

Strategic Uses for Targeted Capital Generation

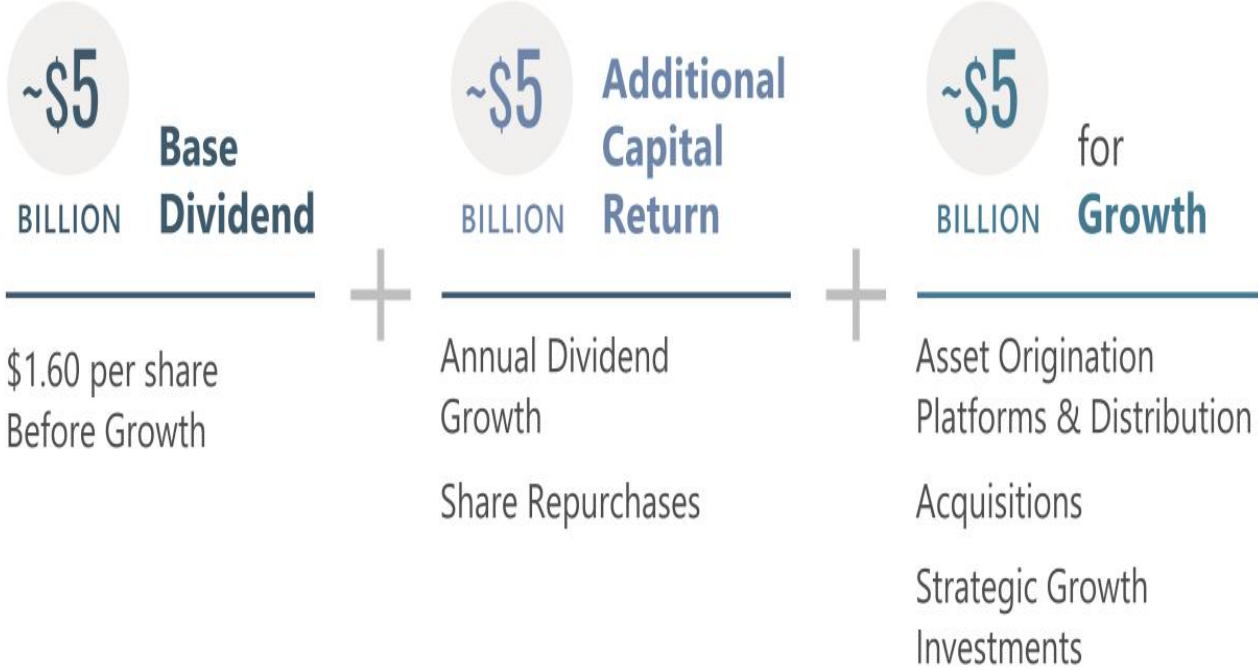

Three Components to Our Firepower

1
~\$100B

Potential embedded
growth from existing
Athene capital

+

2
\$10B ▶ ~\$20B

Available strategic growth
capital within Athene
alternative portfolio

+

3
~\$5B

Estimated capital earmarked
for strategic growth
over next 5 years

~\$100B of Embedded Growth Potential +
~\$15B of Expected Aggregate Capital Available

5

Strong Momentum Behind Aligned Team

Tomorrow's Apollo Will... **Be Larger and More Profitable**



**DOUBLE ASSETS
UNDER MANAGEMENT**



**MORE THAN
DOUBLE EARNINGS**

...Before
Benefit of
Investing ~\$5B
for Growth

1. "Tomorrow" represents 2026E. 2. "Today" reflects LTM ended June 30, 2021 normalized spread related earnings. 3. Pro-forma for post merger share count of approximately 600mm shares, including anticipated equity awards related to compensation reset, and assumed tax rate of 18%.

Tomorrow's Apollo Will... **Generate More Capital**

LAST 5 YEARS

\$5 billion of Distributable Earnings generated

>90% cumulative Payout Ratio on DE

—
—

BUSINESS STARVED OF GROWTH CAPITAL

NEXT 5 YEARS

Projecting \$15 billion of capital generation, \$5 billion for growth

Dividend grows as FRE grows

—
—

BUSINESS WILL HAVE PLENTIFUL GROWTH CAPITAL AVAILABLE

Note: Last 5 years generally representative of 2016-2020. Next 5 years representative of 2022-2026.

APOLLO INVESTOR DAY 2021

70

Tomorrow's Apollo Will... **Be More Aligned With Employees**



Undertaking a holistic and necessary **revamp of our comp model...**



...which we believe drives a **powerful and positive impact** as we execute for our shareholders

Greater emphasis on stock compensation; one-time equity investment in alignment concurrent with merger

Give employees greater share of incentive fees undervalued by market

Strengthens employee alignment with investment performance

Stronger alignment with stock performance

Better continuity and longer tenure

Improves long-term FRE margin potential

Aligning Compensation Structure with Shareholders

GREATER PORTION OF COMPENSATION ALIGNED WITH VARIABLE PERFORMANCE FEES

FRE COMPENSATION RATIO

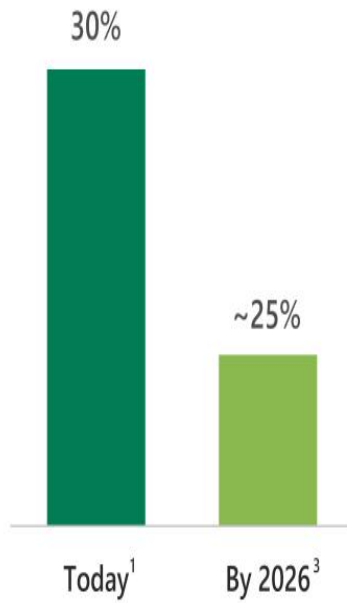

PRINCIPAL INVESTING COMP RATIO

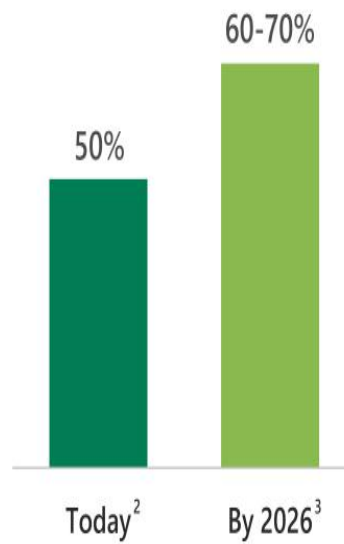

1. As of LTM 2021. 2. Reflects average PII compensation ratio from 2020A to 2021E. 3. Reflects anticipated pro-forma allocation of expenses across segments. Principal Investing comp ratio is indicative based on average expected revenues from 2022E-2026E.

It's All About Talent

BRINGING WORLD CLASS SENIOR TALENT TO APOLLO



Renee Anderson
MD, Chief Operating Officer, Technology



Ian Bell
Partner, Head of Asia Sales



Jason D'Silva
MD, Investment Technology and Innovation



Craig Farr
Senior Partner, Capital Solutions



Roger W. Ferguson Jr.
Vice Chairman



Courtney Garcia
MD, Head of Market Risk



Gemma Gucci
MD, Global Head of Talent Acquisition



Noah Gunn
MD, Global Head of Investor Relations



Earl Hunt
Partner, CEO of Apollo Debt Solutions & Co-Head of Credit LP Secondaries



Susan Kendall
MD, Global Head of Strategic Finance



Olga Kusters
MD, Credit Secondaries



David Krone
Senior Partner, Global Head of Public Policy



David Lang
MD, Chief Operating Officer, Enterprise Solutions



Yael Levy
Chief Compliance Officer



Bill Lewis
Senior Partner, Private Equity



Vikram Mahidhar
Operating Partner, Data, Advanced Analytics & Digital Transformation



Howard Nifoussi
MD, Head of U.S. Wealth Management



Ria Nova
Partner, Client & Partner Solutions



Jason Ourman
Partner, Apollo Global Real Estate



Jeff Sayers
Senior Partner, Head of Insurance Solutions Group International



David Stangis
Senior Partner, Chief Sustainability Officer

APOLLO INVESTOR DAY 2021

Tomorrow's Apollo Will... **Be More Investable**



**One Share,
One Vote**
Structure with
Full C-Corp
Conversion¹



**Enhanced
Corporate
Governance**
with Majority
Independent
Board



**Larger Market
Capitalization**
with Greater
Liquidity
and Broader
Shareholder
Base



**Additional
Index
Eligibility,**
including
S&P 500

1. To take effect following closing of previously announced merger with Athene.

Tomorrow's Apollo Will... **Do More Good**



Dedication to Promoting ESG & Sustainability



Focus on Responsible Due Diligence



Engagement Throughout Ownership



Data Availability, Transparency and Expanding Across the Platform



Expanding Opportunity



**INVESTOR
DAY 2021**

Culture at Apollo

VIDEO MODULE



**INVESTOR
DAY 2021**

Yield Overview

JIM ZELTER

Co-President



The Premier Yield Franchise

\$339B

TOTAL GLOBAL YIELD AUM

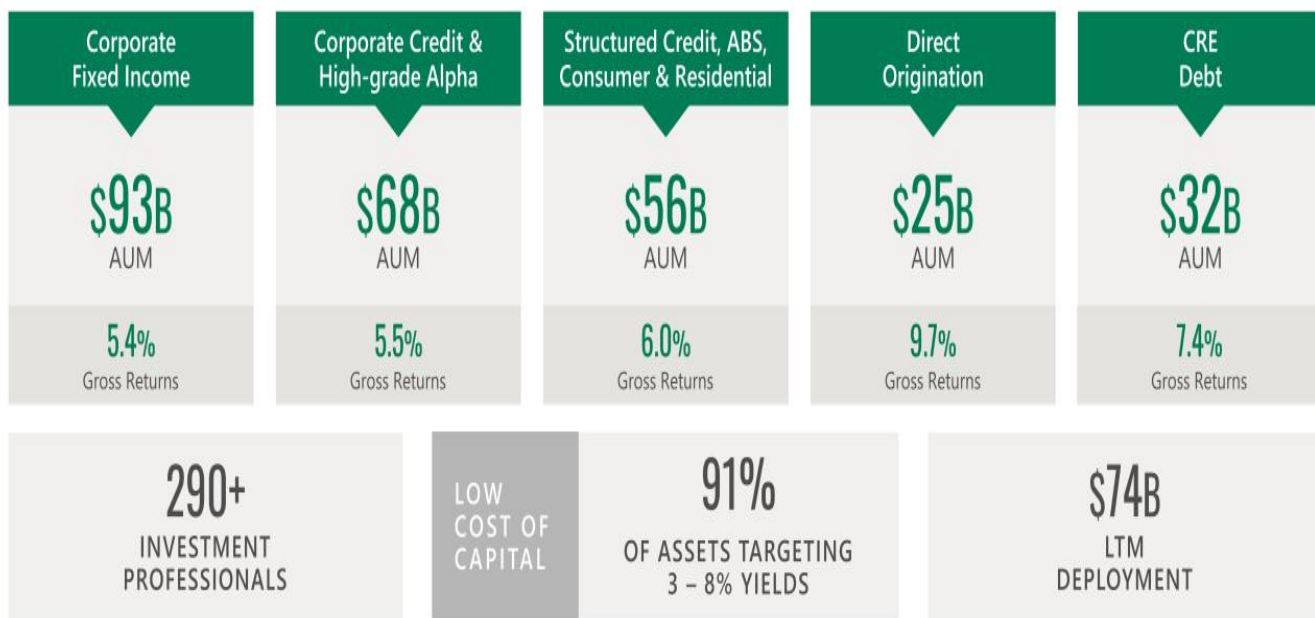

Note: Total Yield AUM includes \$65B of Advisory & Other Assets. All returns shown are gross five-year returns as of June 30, 2021.

APOLLO INVESTOR DAY 2021

We Expect to Double Our Yield Businesses in the Next Five Years

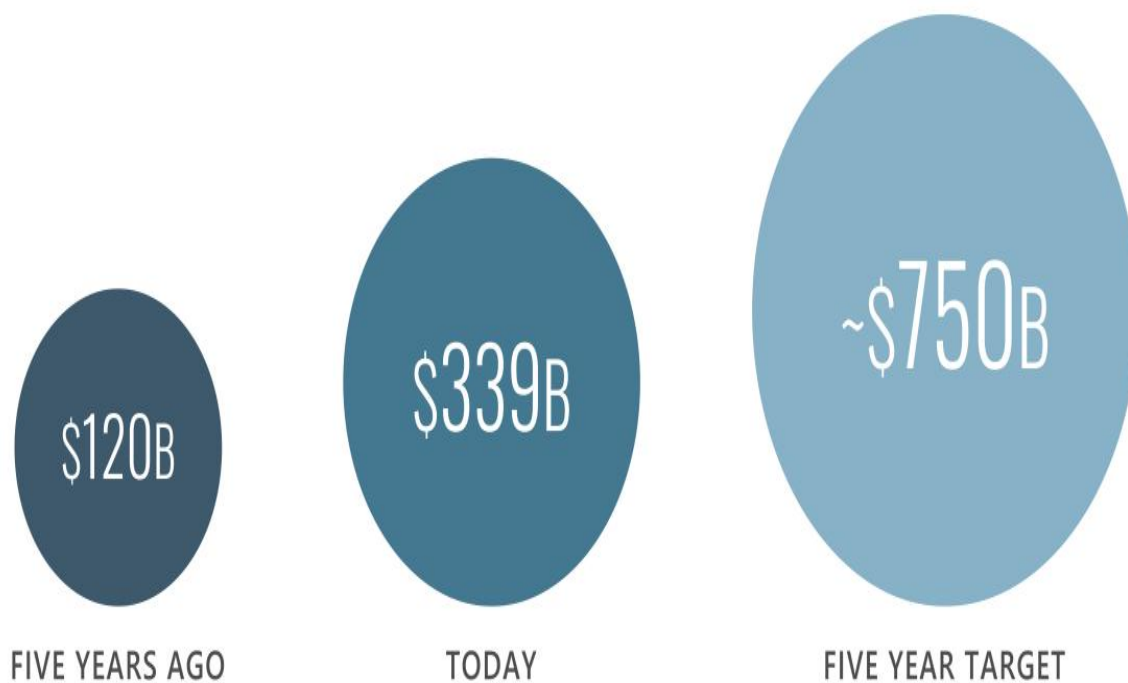

Note: AUM Five Years Ago as of December 31, 2016.

APOLLO INVESTOR DAY 2021

Our Yield Roots Started in Private Credit...

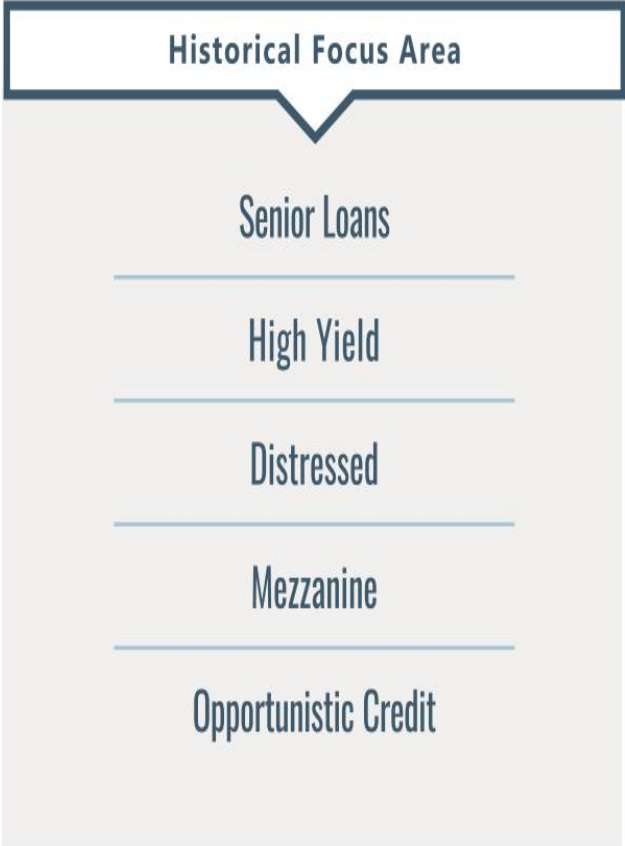

Note: All returns shown are gross returns. 1. Gross IRR represents Hybrid Value Fund I.

...But the Fixed Income Replacement Opportunity Is Broader Than "Private Credit"

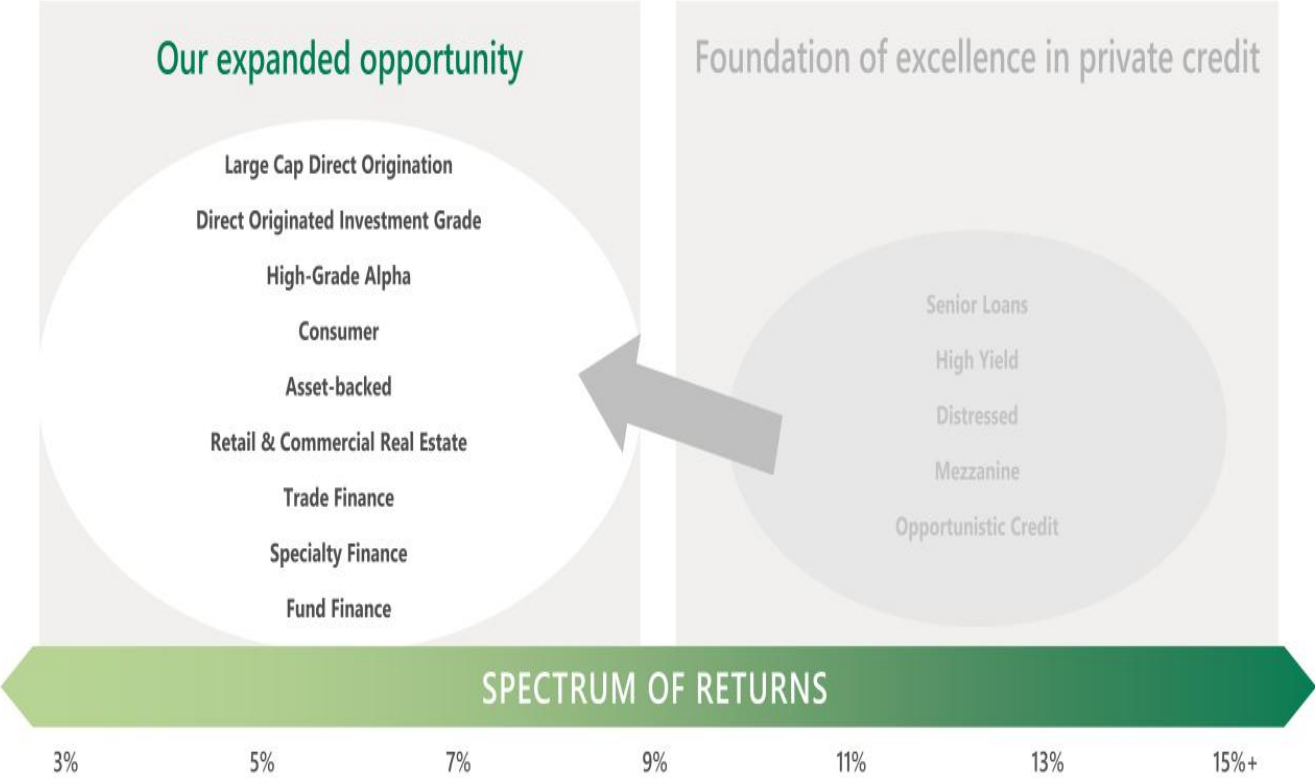

Significant room for growth in Yield given our relationship with Athene and low cost of capital

Note: All returns shown are gross returns.
APOLLO INVESTOR DAY 2021

Apollo Provides Solutions Across The Entire "Fixed Income Replacement Universe"

FINANCING MARKET

PEER FOCUS AREA¹

APOLLO FOCUS AREA²

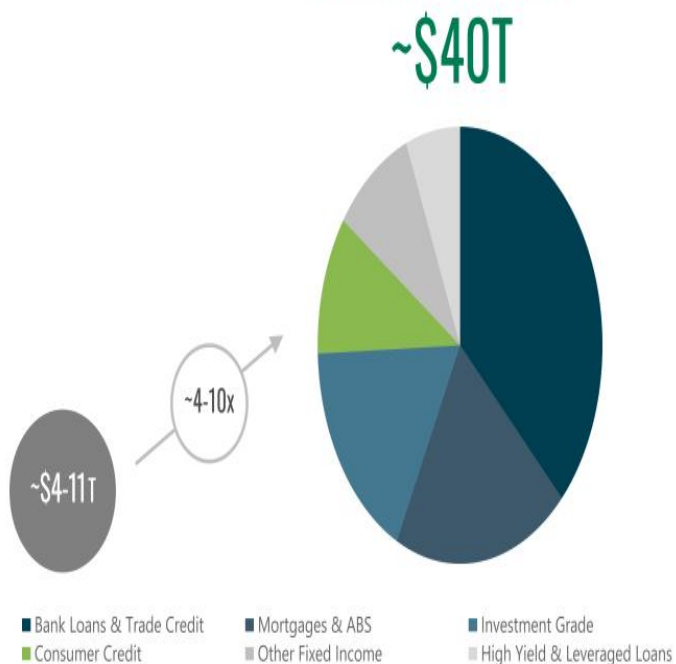

HOW WE SEE THE OPPORTUNITY

- Growth in Private Credit is just the beginning
- Fixed Income Replacement is the new mantra
- Scale and broad capabilities lead to investor solutions
- Global demand for yield and excess return
- Focus area ~4-10x the size of our peers

1. Based on peer disclosures from ARES & KKR. 2. Based on Apollo estimates. Sources: Apollo Chief Economist, Federal Reserve Board, S&P LCD, BoFA, Preqin, SIFMA, Haver Analytics, Bloomberg.

The Components for Success

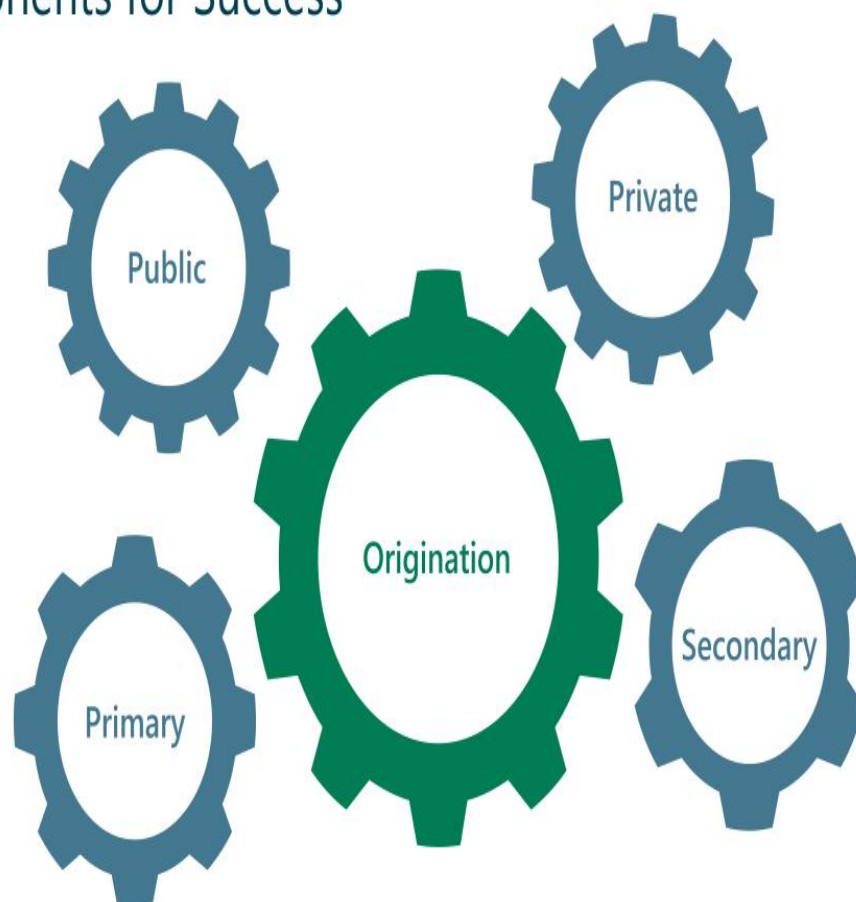

Holistic solutions across all facets of Yield

Our Building Blocks Make Us a Preferred Capital Partner

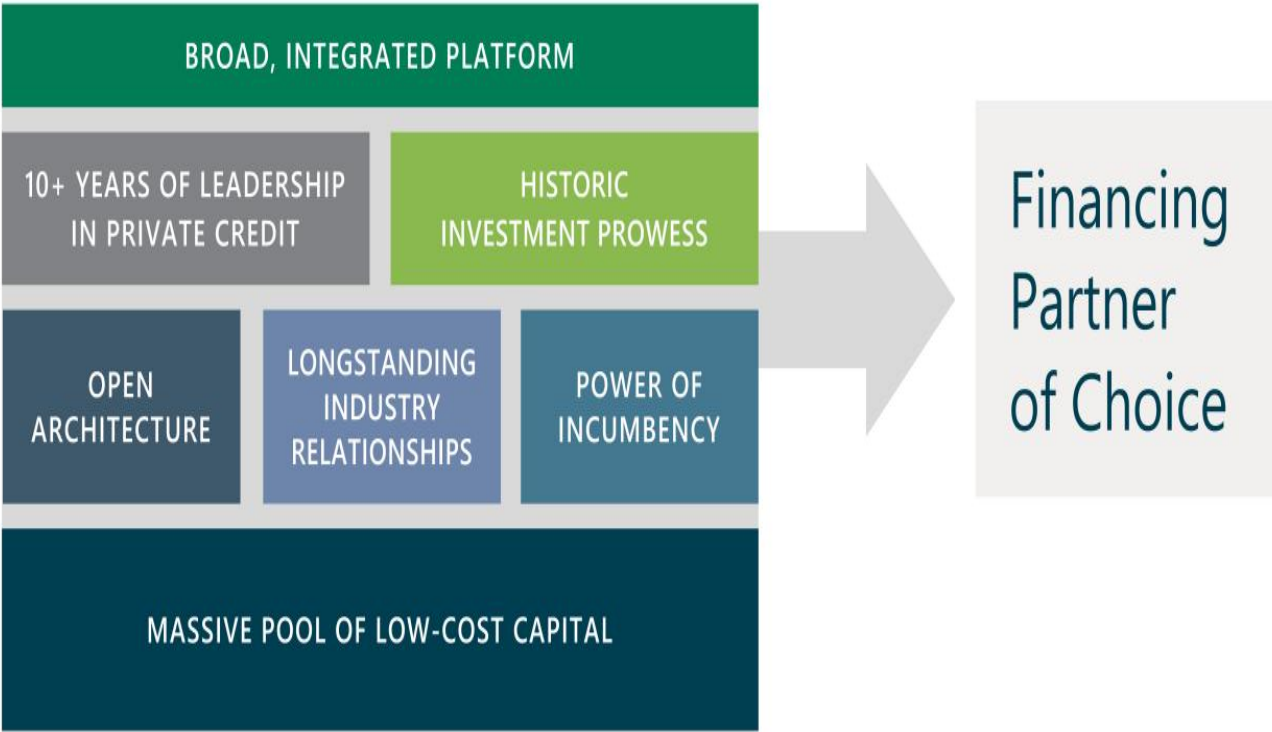

Hertz: Lifecycle of a Trade

FLEXIBLE CAPITAL:
Sourcing the best risk-return within a capital structure

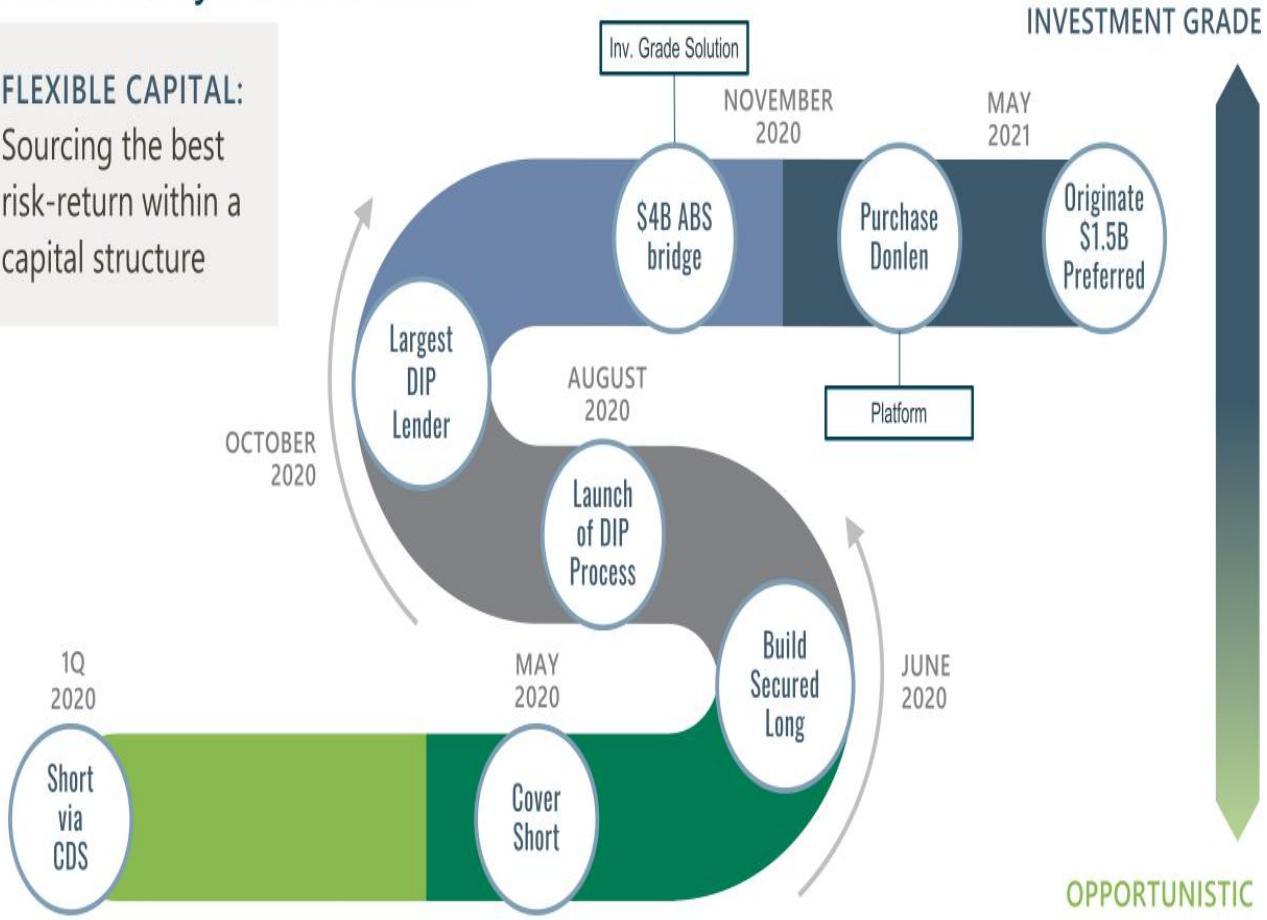

As of May 2021. Investment example has been provided for discussion purposes only. Represents the views and opinions of Apollo Analysts. Subject to change at any time and without notice. There is no guarantee of future results or that similar investment opportunities will become available in the future or, if available, that such opportunities will achieve target returns. Investment example was selected using an objective, non-performance-based criteria, because it represents a recent cross-platform transaction.

Leader in Responding to Secular Change

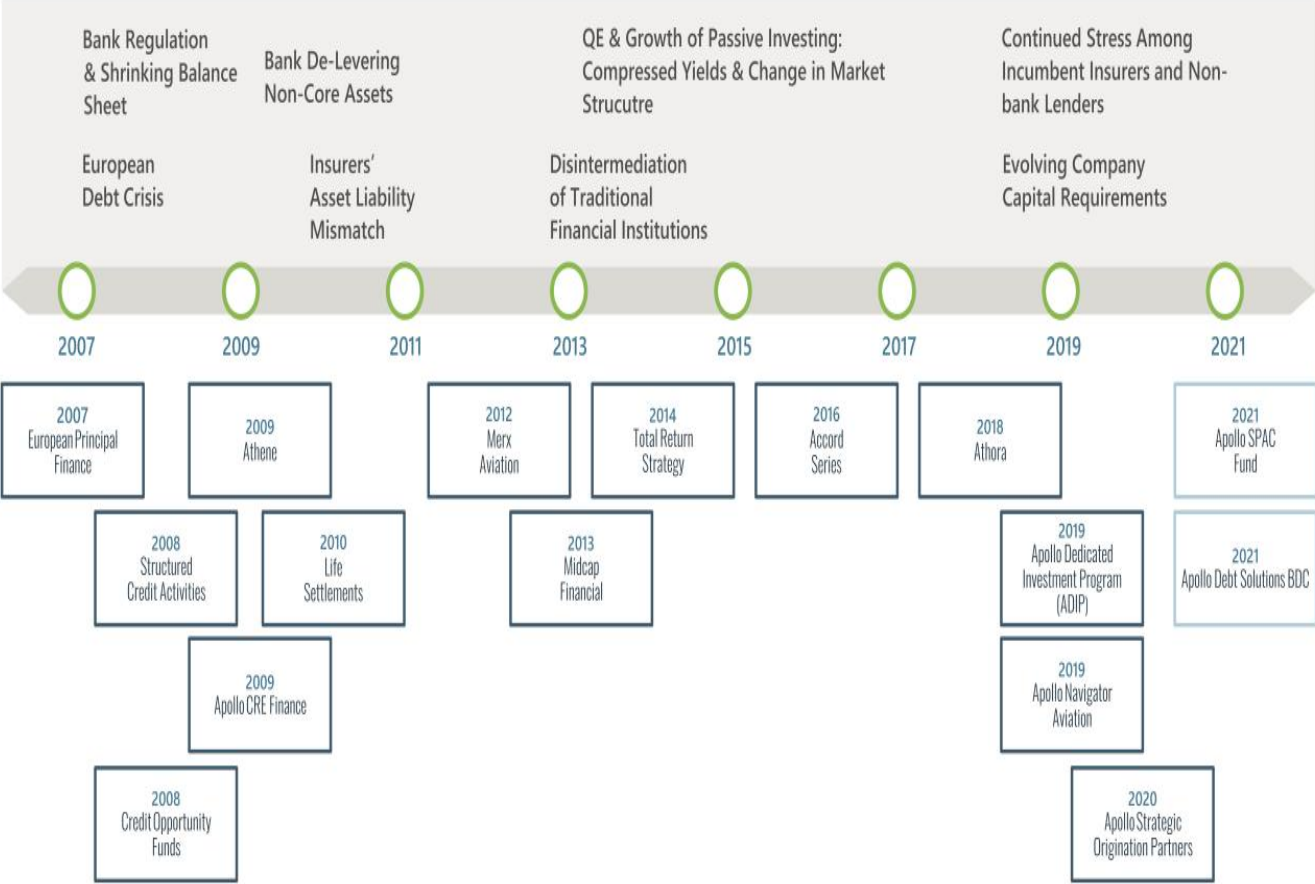

Source: Apollo Analysts as of June 30, 2021. The above is not an exhaustive list.

Historical Success by Being a First Mover



DEDICATED RETIREMENT SERVICES ASSET MGMT



DISLOCATED CREDIT



LARGE CORPORATE DIRECT ORIGATION



CREDIT SECONDARIES

OUTCOME

\$255B AUM

Athene returns of **4.5%**, ~30bps better than peers, net of fees¹

\$5B dedicated AUM

Leveraging 31-year history with distressed expertise

\$21B AUM

Supporting material industry shift of large borrowers going private

\$1B Purchasing Power

Portfolio solutions given breadth and diversity of capital

Source: S&P Financial, Company Filings. Footnote explanations may be found in presentation endnotes.
APOLLO INVESTOR DAY 2021

How Do We Grow the Franchise From Here?

DURATION



No compensation
in today's market

SUBORDINATION



No compensation
in today's market

ORIGINATION



Ability to earn
attractive yield
and attractive
economics

Why We Like Origination



Power of incumbency across entire platform



Control of structure, process, and documents



In-depth knowledge to minimize credit risk and own the collateral



Ability to earn attractive economics



Trade-off liquidity risk for a premium

Secular Tailwinds Will Help Drive Growth in Origination Volume

BANK SHARE REDUCING AMID INCREASED REGULATORY PRESSURES...

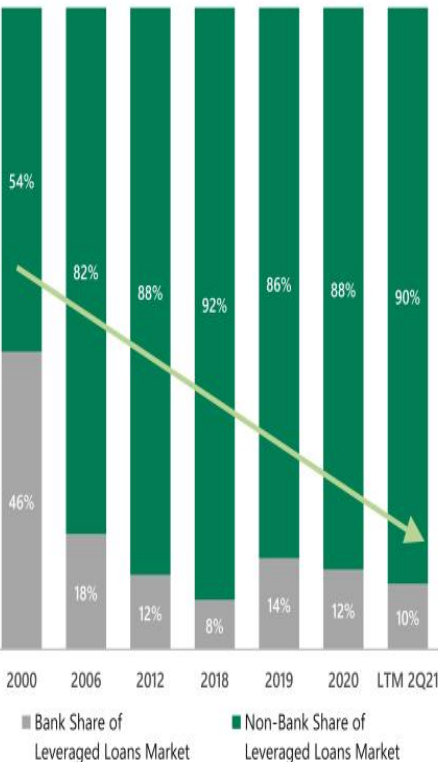

...BUT DEMAND FOR CORPORATE LENDING HAS FLOURISHED

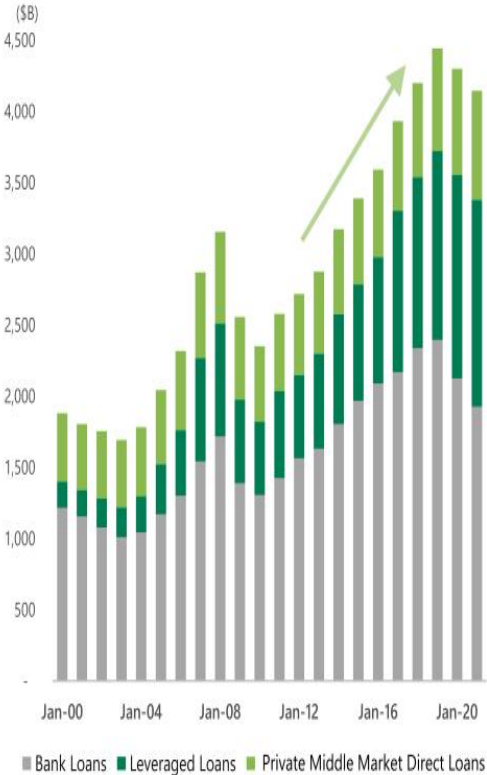

- Demand for alternative sources of capital continues to increase
- Apollo benefits from flexible matched capital with appropriate duration and risk appetite
- 2020 proved the resilience of our model

Source: Bank of America as of June 2021.
 APOLLO INVESTOR DAY 2021

Multi-Pronged Approach to Origination

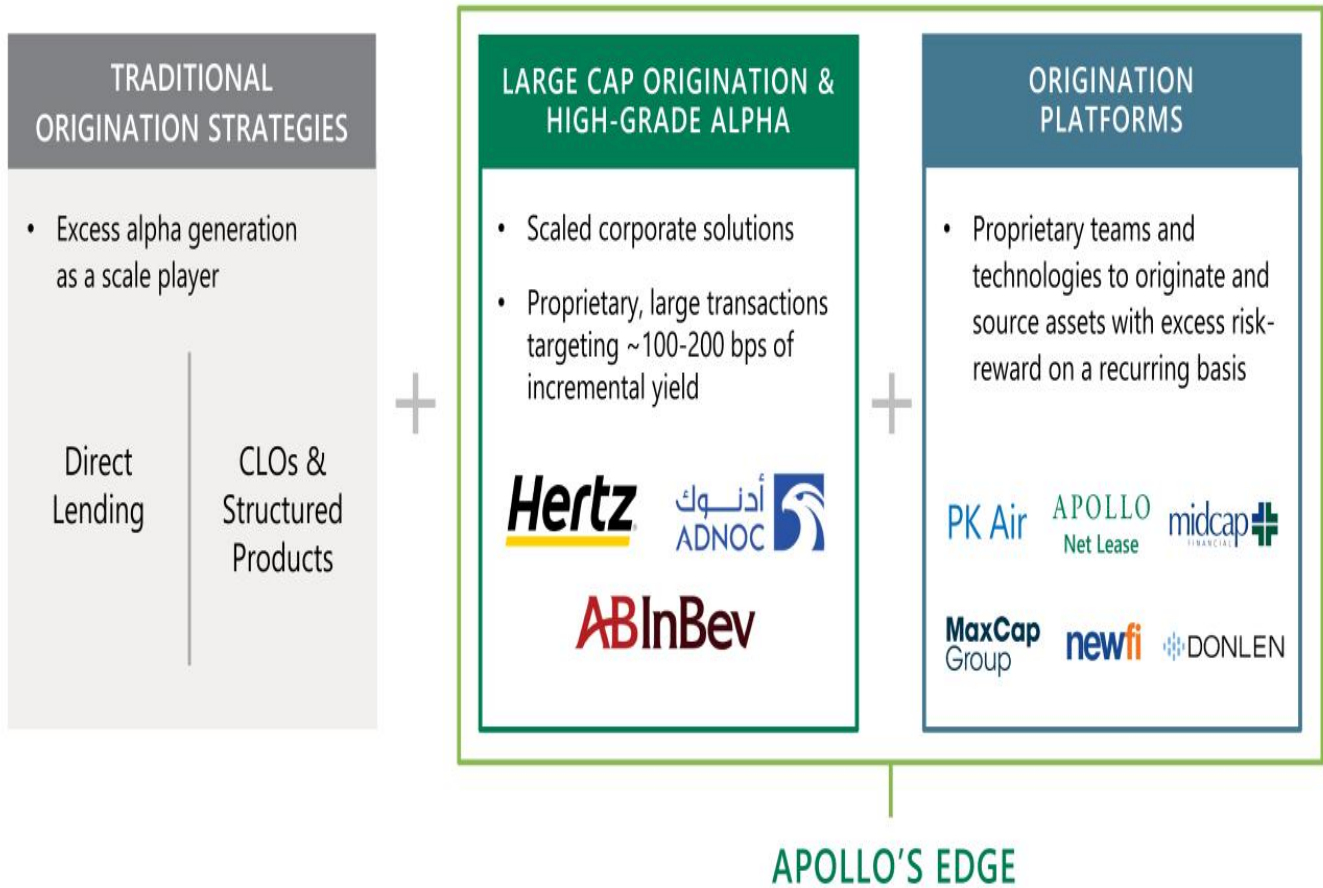

Scaling Through All Three Origination Channels

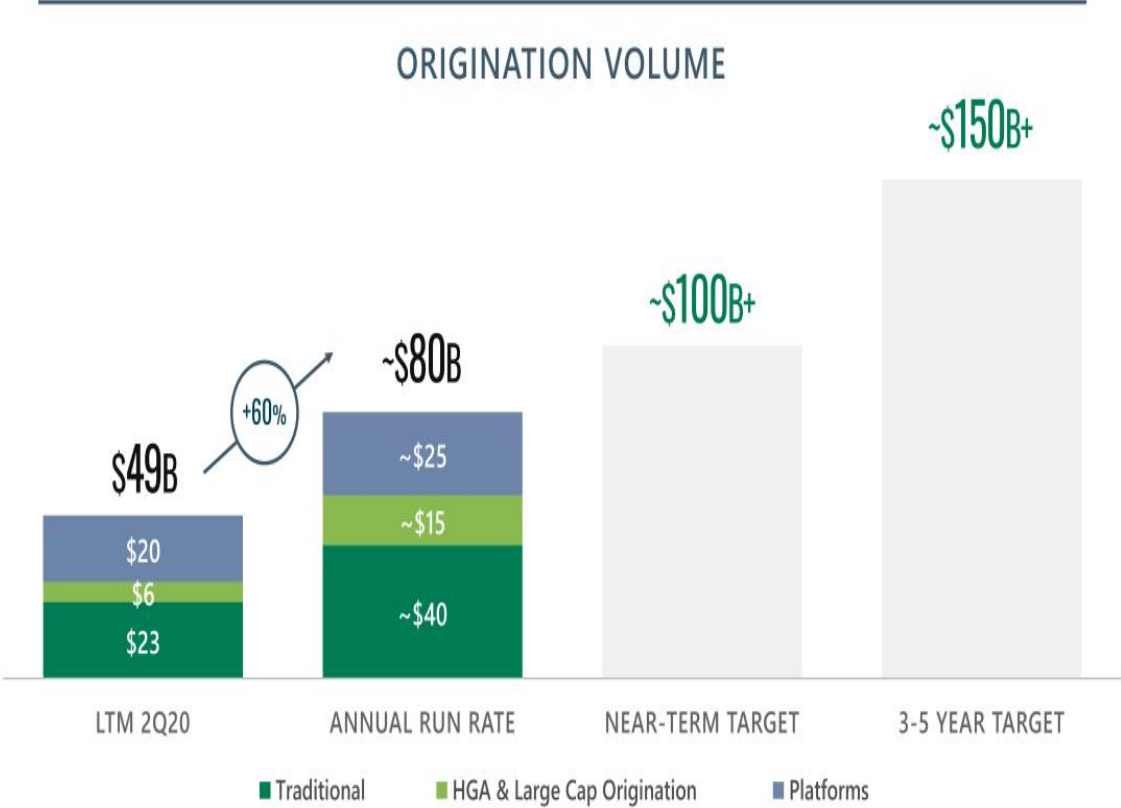

Strong Yield Leadership with the Ability to Attract Top Talent

STRONG SENIOR LEADERSHIP WITH 23 YEARS AVERAGE INDUSTRY EXPERIENCE



JOHN ZITO Deputy CIO, Credit	NANCY DE LIBAN Head of Resi./Consumer Structured Products	CRAIG FARR Head of Apollo Capital Solutions	JIM GALOWSKI Head of European Credit	ROB GRAHAM Resi./Consumer Credit	JIM HASSETT Head of Corporate Fixed Income	EARL HUNT Partner, CEO of Apollo Debt Solutions & Co- Head of Credit LP Secondaries	JEFF JACOBS CIO, Insurance Solutions Group	BRET LEAS Head of Global Corp. Structured Credit & ABS	LESLIE MAPONDERA Partner, European Investment Grade	JOE MORONEY Co-Head Corporate & Multi-Credit	MATT O'MARA Alternatives, Insurance Solutions Group	BRIGETTE POSCH Head of Emerging Markets Credit	SCOTT WEINER Head of CRE Debt	HOWARD WIDRA Head of Direct Origination	JASJIT SINGH Chief Risk Officer
---	--	---	--	---	--	---	--	--	--	--	--	--	--	--	--

~80 BEST-IN-CLASS CREDIT HIRES OVER THE LAST 18 MONTHS

PARTNER AT GOLDMAN SACHS	HEAD OF EQUITIES AND CREDIT TRADING AT NOMURA
HEAD OF CREDIT TRADING AT BARCLAYS	PORTFOLIO MANAGER AT ELLIOTT
HEAD OF CREDIT AND CAPITAL MARKETS AT KKR	MANAGING DIRECTOR AT ALCENTRA

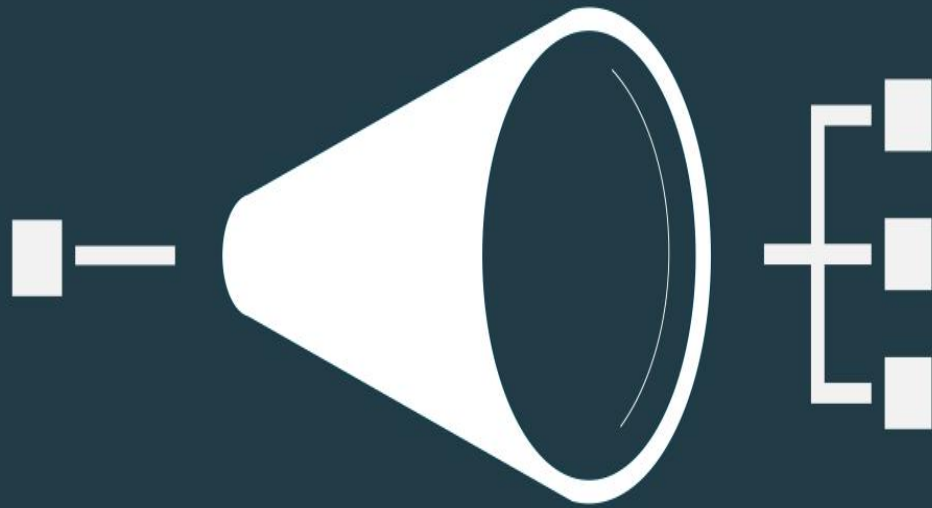

CAPITAL SOLUTIONS BROADENS OUR DISTRIBUTION FUNNEL

Our Originated Assets Have Multiple Homes

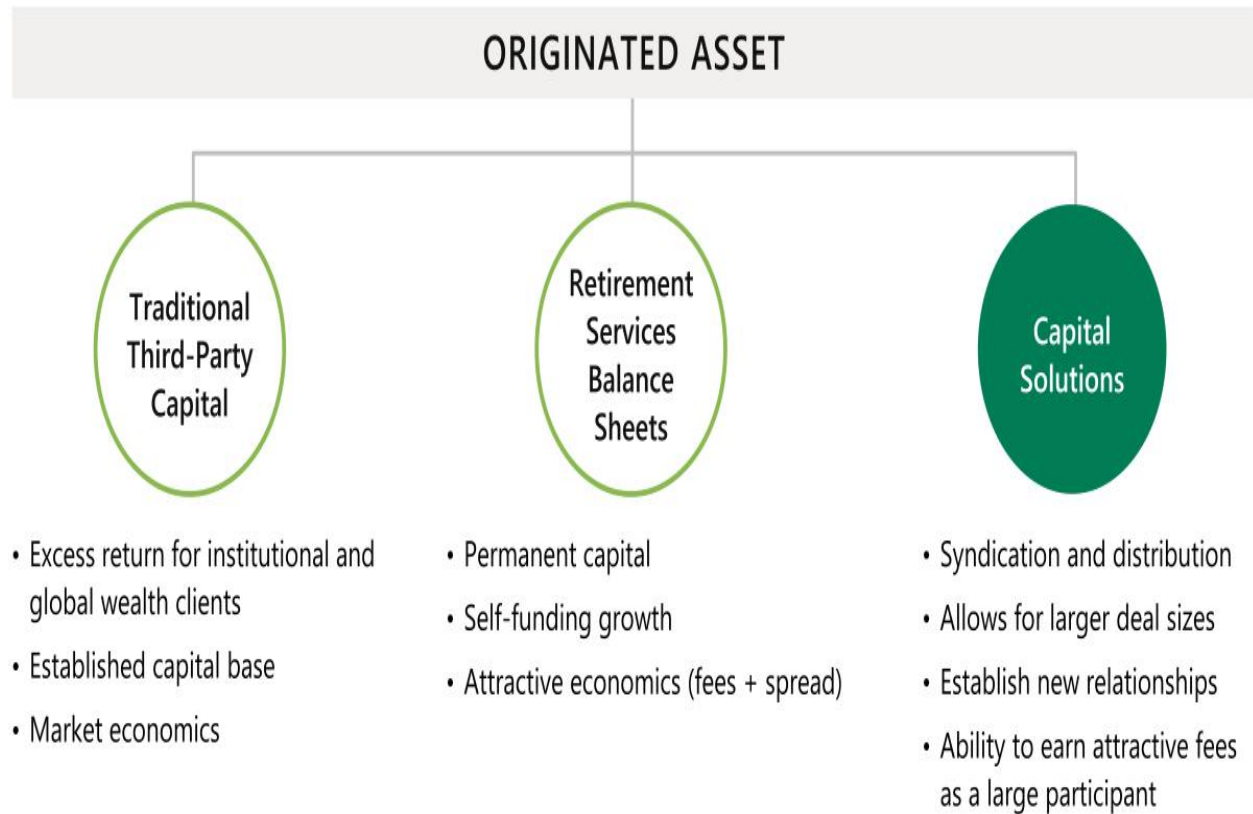

Apollo Capital Solutions Further Expands Our Toolkit

FEE RELATED REVENUE

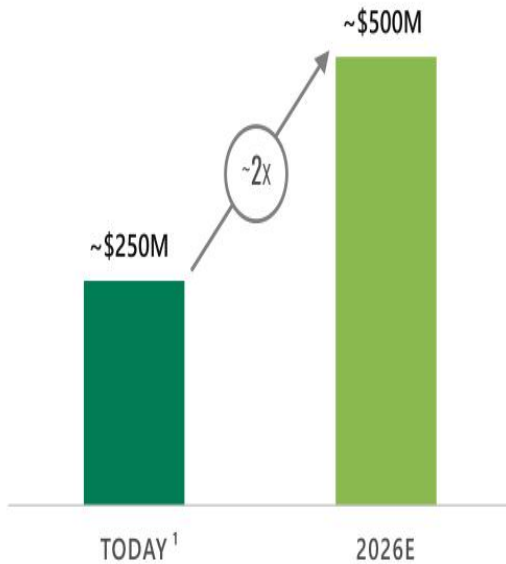

MULTIPLE LEVERS FOR FRE GROWTH

- 1 Large existing portfolio with capital markets activity
- 2 Premier yield and origination franchise
- 3 Excess flow across scaling strategies

Centralized solution supporting cross-platform origination, structuring, and syndication that is expected to drive FRE growth

1. For presentation purposes, LTM 2021 fee related revenue from transaction and advisory fees excludes monitoring and miscellaneous fees from the private equity segment recognized over the same period.

Key Takeaways for Our Yield and Capital Solutions Businesses

1

Private Credit is evolving into Fixed Income Replacement, a market which is magnitudes larger

2

Apollo's differentiated scale and cost of capital drives our competitive edge in origination

3

Capital Solutions expands our toolkit for distributing investments to our clients

4

We believe we have the capabilities and experience to drive sustainable growth and create enterprise value

INVESTOR
DAY 2021

Origination Platforms

CHRIS EDSON

Senior Partner, Co-Head of US FIG



Access to Direct Origination Is Now More Important Than Ever

TRADITIONAL ASSET BUYER

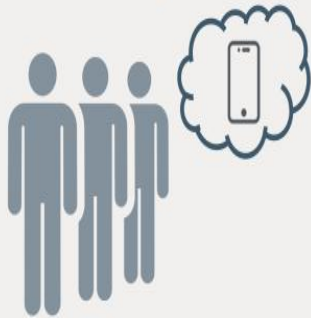

Increasing Demand in
Low Yield Environment

DIRECT ORIGINATION PLATFORM



Perpetual and
Recurring Supply

Owning origination platforms provides **perpetual¹**, recurring access to attractive assets at scale

1. Platforms are ongoing businesses that we may potentially never sell and thus provide us with the opportunity to originate assets over an indefinite time period.

Origination Platforms Drive Permanent Asset Growth

HOW DO WE DEFINE ORIGINATION PLATFORMS?

Origination platforms are best-in-class businesses, teams and technologies that originate assets with excess risk-reward on a sustainable and recurring basis

APOLLO'S EXISTING ORIGINATION PLATFORMS



What Can Direct Origination Offer Apollo and Apollo Clients?

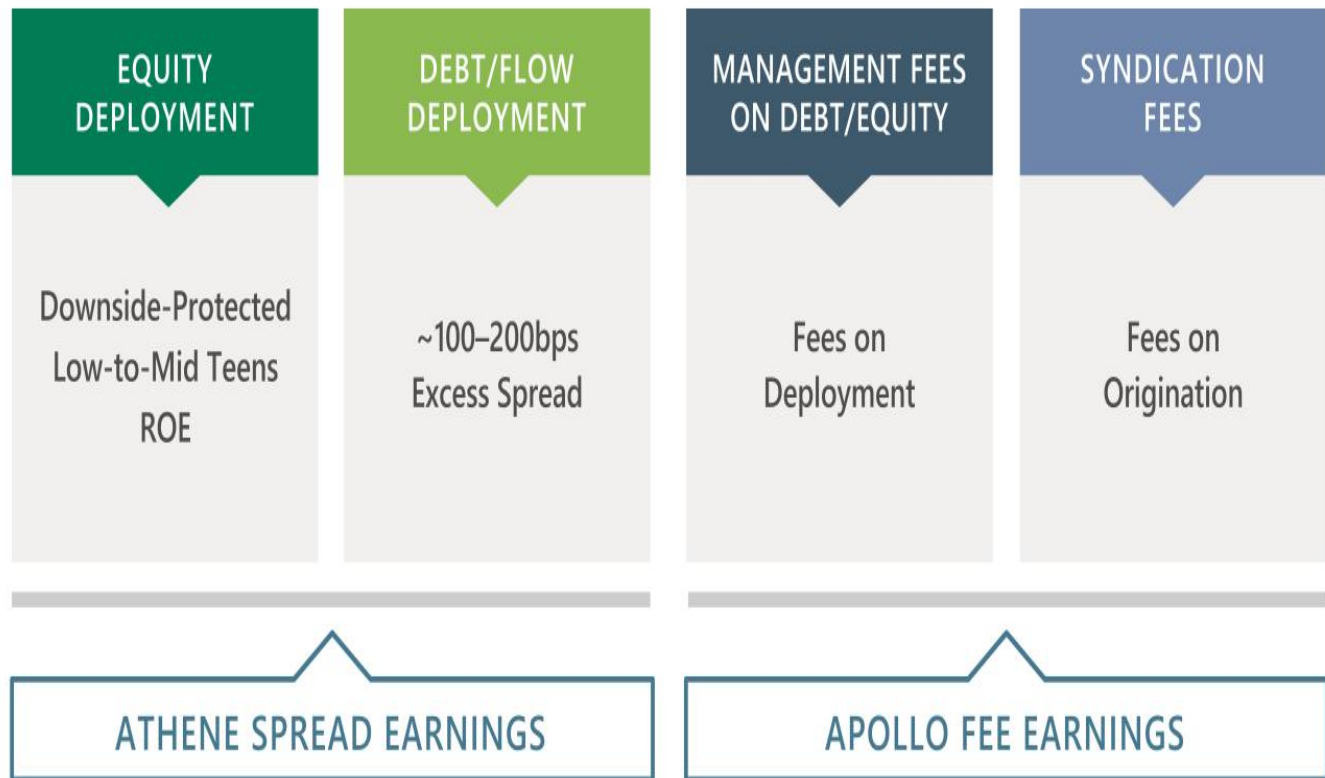

Manufacturing Spread in a Low Spread World

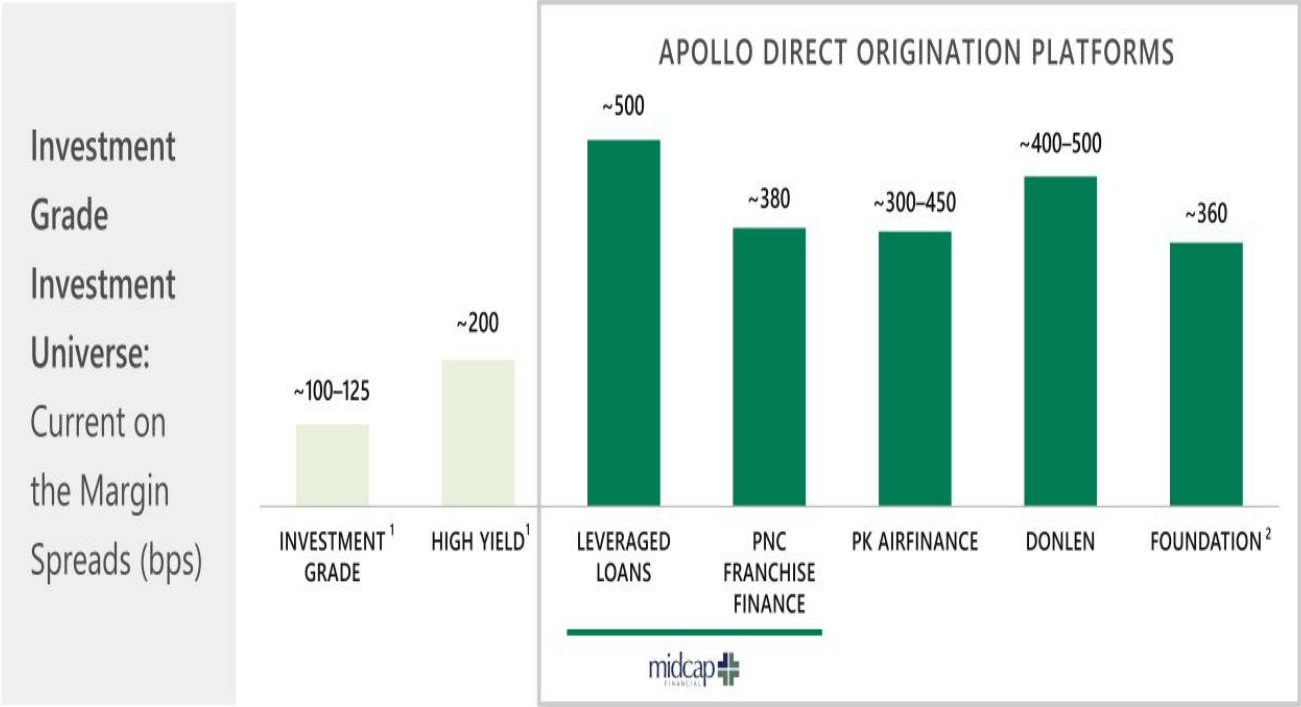

Apollo direct origination platforms systematically originate IG assets at ~100–200bps higher spreads than broadly syndicated markets

1. Illustrative spreads based on market prices observed for BBB corporates (IG) and BB corporates (HY), as of September 2021. 2. Acquisition of Foundation is signed but not yet closed.

Apollo Origination Platforms Represent Our Differentiated View

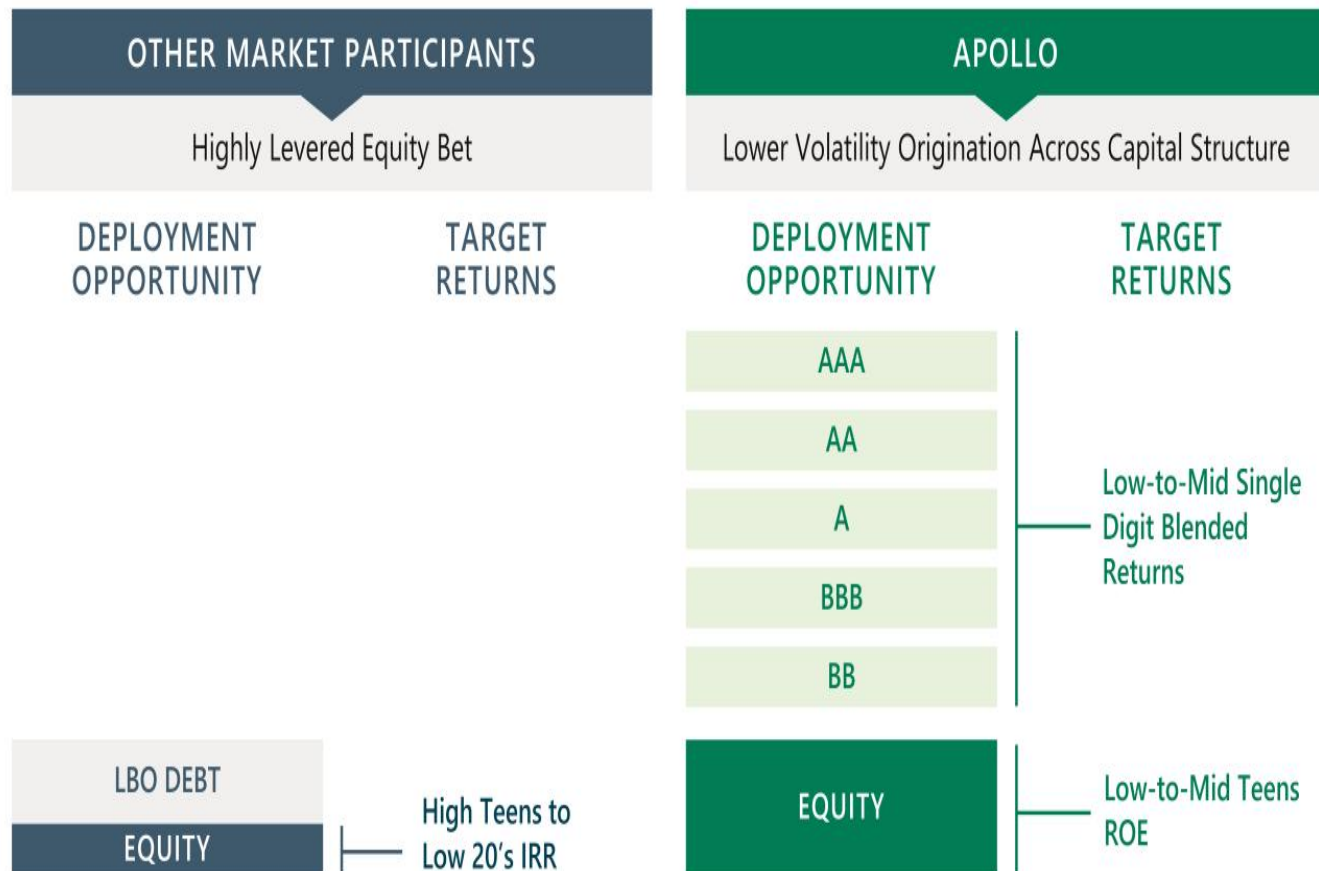

Why “Holding the Underwriting Pen” Is Better than Buying CUSIPs

	BROADLY SYNDICATED LOANS	APOLLO DIRECT ORIENTATION PLATFORMS
Credit Documentation Control	✗	✓
Due Diligence Access	PARTIAL	FULL
Relationship with Borrower	LIMITED	COMPREHENSIVE
Origination and Spread Economics	✗	✓
Syndication Control	✗	✓
Recurring Flow and Allocation Control	✗	✓
Granularity	CONCENTRATED	GRANULAR

We believe directly originating assets drives better risk-adjusted returns

MidCap Serves as a Case Study for Origination Platforms

ORIGINATION GROWTH

GLOBAL SCALE AND FOOTPRINT

LOW LOSSES

~\$2B

in 2014



~\$15B

Today

200+

Employees

WORKING
TOGETHER
FROM

12

Offices Globally

35bps

Since 2003

OPPORTUNITIES CREATED FOR APOLLO AND APOLLO CLIENTS

~\$2.5B permanent
equity deployment

low-to-mid teens dividend yield
low-to-mid teens ROE

~\$4B debt origination
for Athene
and Athora

~\$5B debt origination
for other
Apollo clients

Management fees
on debt
and equity

MidCap provides a playbook to scale our other platforms and penetrate new markets

Platforms Create Significant Value for Apollo and Apollo Clients

REAL-TIME EXAMPLE

APOLLO CLIENTS



APOLLO



There Are Plenty of Growth Opportunities Ahead

DEVELOPED	HIGH GROWTH			WHITESPACE
\$25B+ in annual originations and ~\$50B in gross assets				
 <p>\$15B ASSETS</p>  <p>\$15B ASSETS</p>	 <p>PK AirFinance</p>  <p>\$8B ASSETS</p>  <p>\$300M ASSETS</p>	 <p>\$500M ASSETS</p>  <p>\$3B ASSETS</p>  <p>\$2B ASSETS</p>	 <p>\$2B ASSETS</p>  <p>\$4B ASSETS</p>	<p>Consumer Finance</p> <p>US Mortgage</p> <p>Continental Europe</p> <p>Asia Pacific</p> <p>GP Solutions</p> <p>Fund Finance</p> <p>Trade Finance</p>

While we have made material progress to date, significant whitespace remains

Origination Platforms Will Benefit from a Virtuous Feedback Loop



Flywheel effect: \$25B+ annual originations to target of \$60B+ in 5 years

Key Takeaways for Our Origination Platform Capabilities

1

Direct origination delivers excess risk-adjusted returns at scale and on a recurring basis

2

Our existing platforms originate tens of billions in assets for Apollo clients every year

3

Origination platforms generate substantial fee income to Apollo

4

Significant runway to scale our existing platforms and fill in whitespace opportunities

INVESTOR
DAY 2021

Capital Solutions

CRAIG FARR

Senior Partner, Capital Solutions



What You've Heard Thus Far...

We **source unique investments** across the entire Apollo platform

We **generate tremendous asset flow** via our Yield, Equity, and Hybrid businesses

Our **origination platforms augment this** with additional yield products

Given ideal holding size, **we often have excess flow...**

...Hence a need for a **centralized utility to execute and syndicate capital markets opportunities**

What is Apollo Capital Solutions?



ORIGINATION

Directly originate more private transactions, provide flexible capital



CAPITAL MARKETS

Competitive pricing, flexible structuring, quick execution



SYNDICATION

Expand our investor reach, speak for greater volume



We Deliver a Broad and Holistic Solution Set for Clients

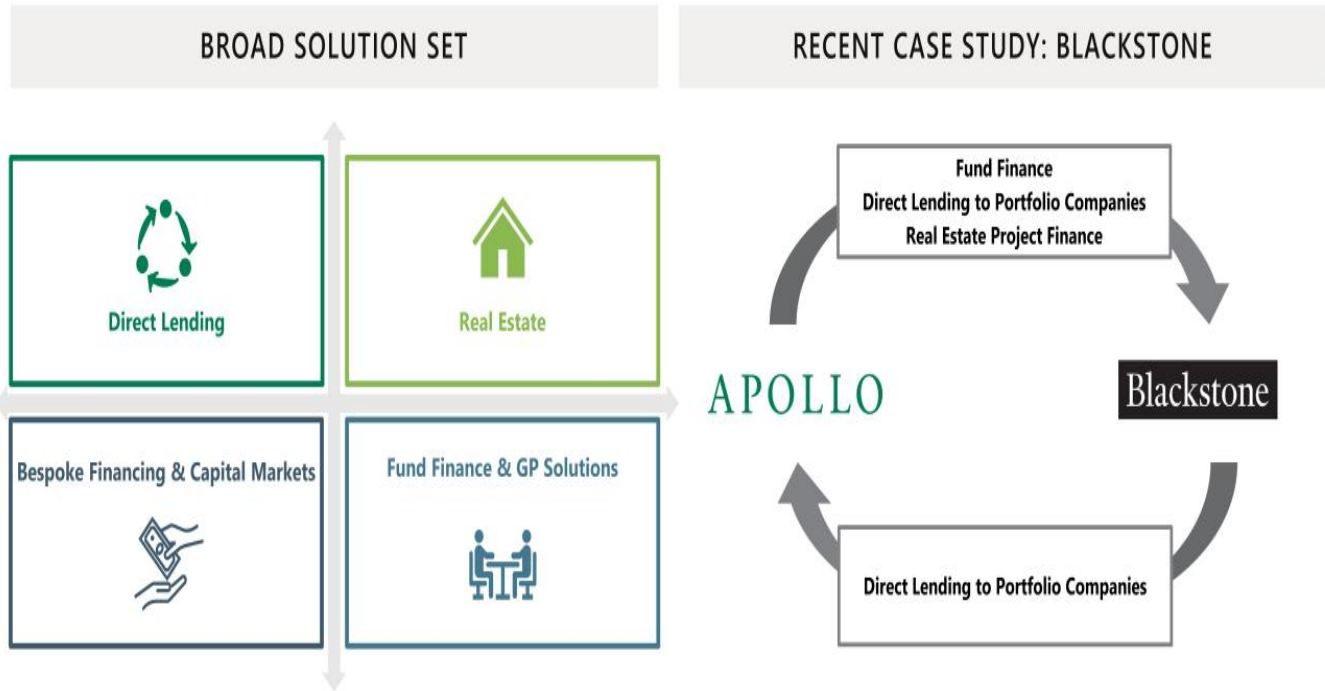

Our breadth of products and long-term capital base are key strategic differentiators

Dedicated Syndication Allows Us to Significantly Expand Our Reach

ADDRESSABLE CHANNELS FOR FLOW & SYNDICATION



■ Apollo Clients
 ■ Traditional Alternative LPs¹
■ Mutual Funds, Hedge Funds, Family Offices²

Significant Potential Incremental Relationships



1. Represents 2020 Private Equity, Private Debt, Real Estate, Infrastructure and Natural Resources AUM. Source: Preqin - Futures of Alternatives 2025. 2. Includes 2020 Hedge Fund AUM of \$3.6T per Preqin - Futures of Alternatives 2025, 2020E Mutual Fund AUM of \$50.2T as of 2020 per PwC - Asset and Wealth Management Revolution, The Future of Financial Services, and Family Office AUM of \$5.9T as of 2019 per Campden Research.

ACS is a Multiplier, Creating Value for Clients and Shareholders

ILLUSTRATIVE APOLLO-ORIGINATED TRANSACTION

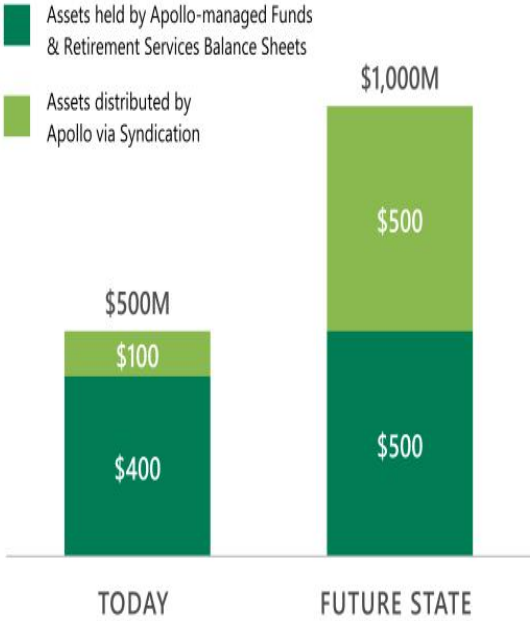

	TODAY	FUTURE STATE
Mgmt. Fees	\$4.0	\$5.0
Carry	\$8.0	\$10.0
Upfront + Syndication	\$1.5	\$7.5
Total	\$13.5M	\$22.5M

Creates a multiplier effect – both increasing economics per unit of capital and allowing us to originate more/larger assets

Apollo is the Perfect Home to Build This Business

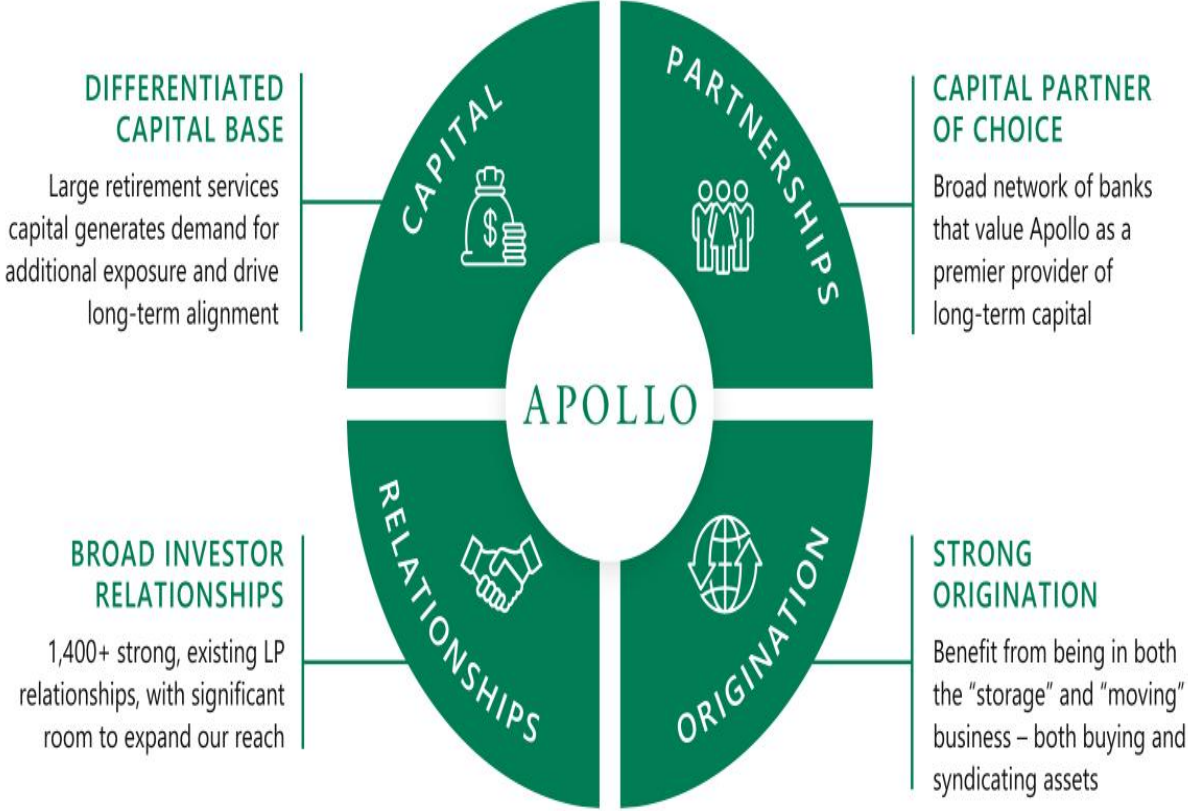

ACS Drives Values for All Stakeholders

Sponsors, Corporates & Banks

Holistic solutions | Dedicated & coordinated coverage | Broader investor & capital base

Limited Partners & Investors

Bespoke sourcing | Better returns
Access to direct deal flow

Shareholders

Greater economics | Fee income |
FRE growth



~2X FEE RELATED
REVENUE GROWTH

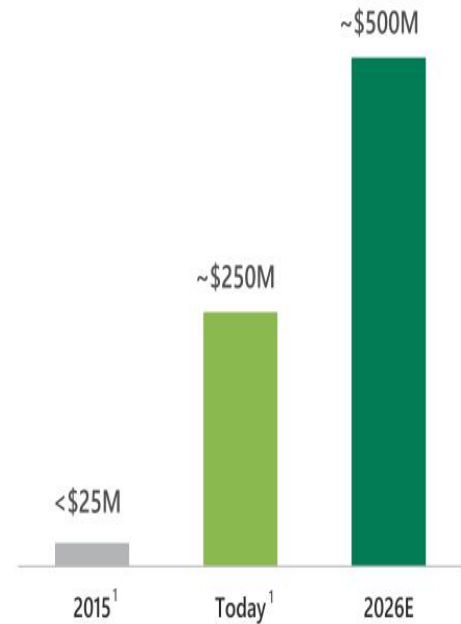

1. For presentation purposes, LTM 2021 fee related revenue from transaction and advisory fees excludes monitoring and miscellaneous fees from the private equity segment recognized over the same period.

We Are Building ACS for the Future of Financial Markets

TODAY

Salesperson-intensive Syndication approach

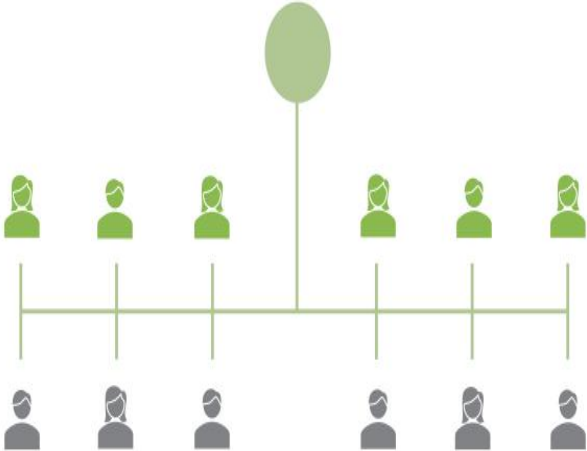

THE FUTURE

More efficient Syndication to a larger investor pool



FinTech is already transforming access to products and funds. Direct deals will be the next frontier.

Key Takeaways for Apollo Capital Solutions

1

Quality of our investments is the key to growth; originate strong assets and capital will quickly follow

2

Dedicated syndication efforts connect our leading investment franchise with expansive capital pools

3

ACS creates a multiplier on Apollo's existing business success, driving accelerated FRE growth and asset generation

**INVESTOR
DAY 2021**

Equity & Hybrid Overview

SCOTT KLEINMAN

Co-President



We Have a Leading Equity and Growing Hybrid Franchise

\$133B

TOTAL EQUITY & HYBRID AUM

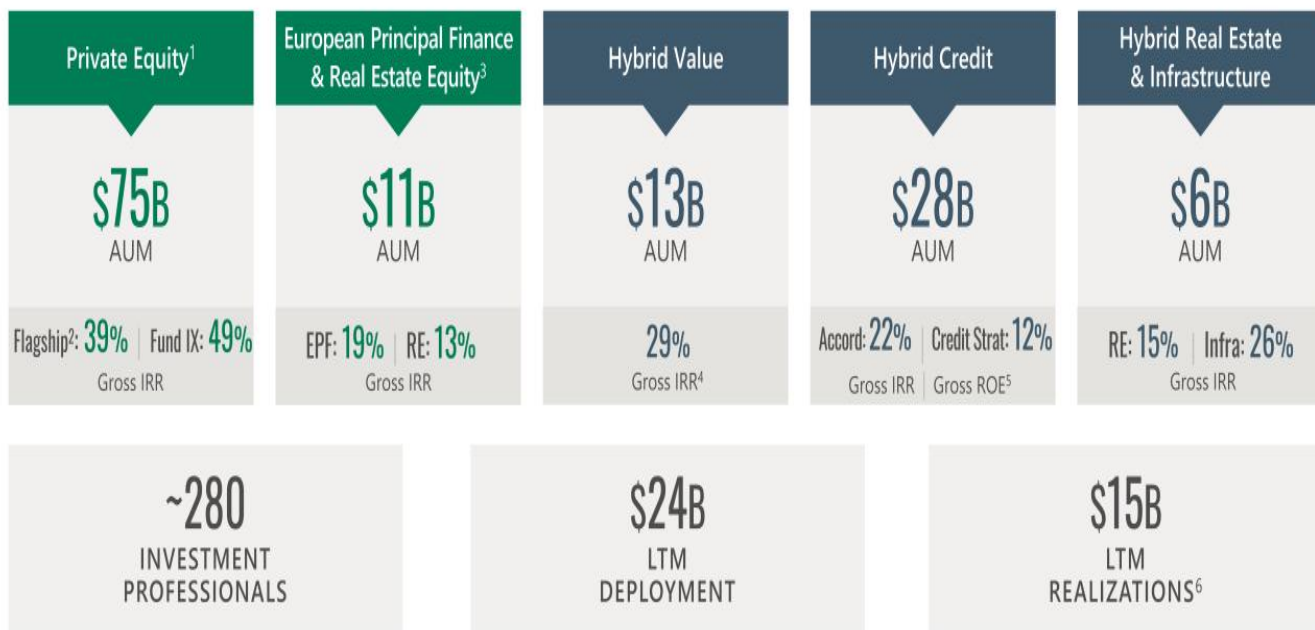

Note: As of June 30, 2021. All returns shown represent franchise returns except Private Equity. 1. Private Equity includes Flagship PE Funds and other adjacent strategies. 2. 39% Gross IRR across Apollo's Flagship Private Equity Funds since inception. 3. Real Estate Equity AUM inclusive of co-invest capital. 4. Gross IRR representative of HVF I only. 5. Gross ROE as of June 30, 2021. 6. Across both Equity and Hybrid combined.

APOLLO INVESTOR DAY 2021

We Expect to Grow Our Equity and Hybrid Business by Over 1.5x

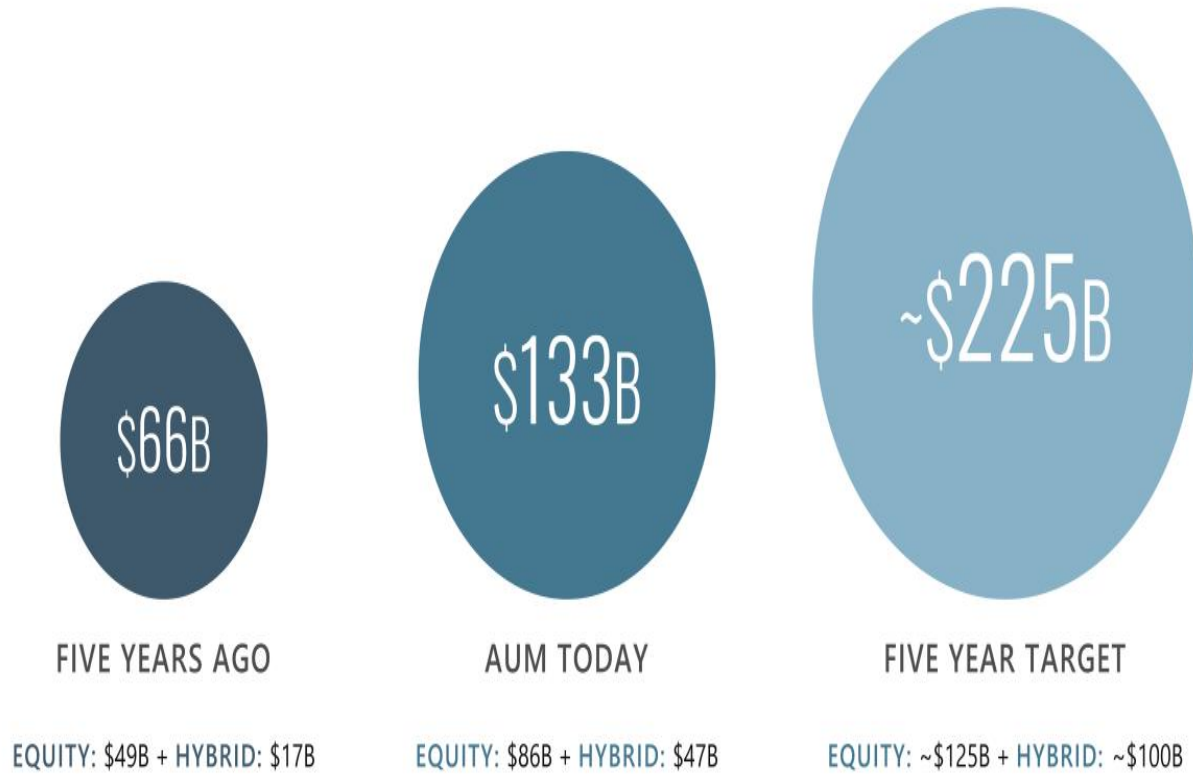

Note: AUM Five Years Ago as of December 31, 2016.
APOLLO INVESTOR DAY 2021

We Have an Industry-leading Equity Franchise, Powered by Flagship Private Equity

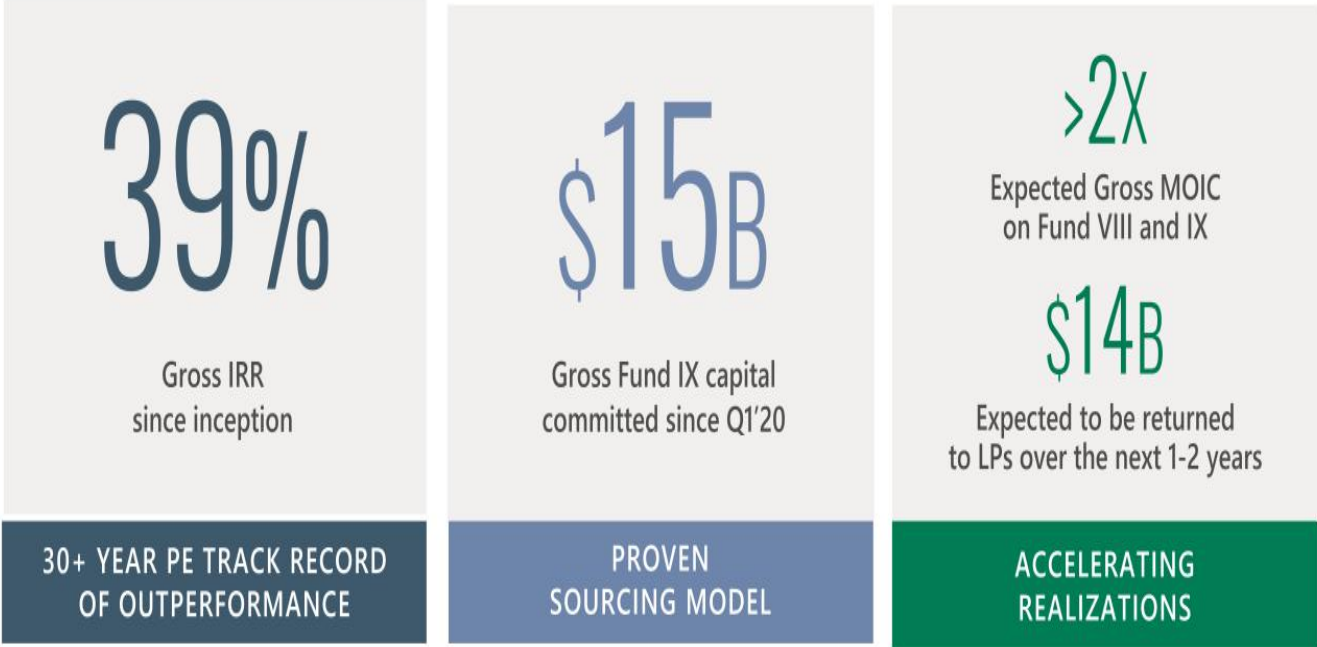

We're expecting to launch Fund X in 2022

Note: As of June 30, 2021, 39% Gross IRR across Apollo's Flagship Private Equity Funds since inception.
APOLLO INVESTOR DAY 2021

Equity Platform Capabilities Drive Alpha Generation

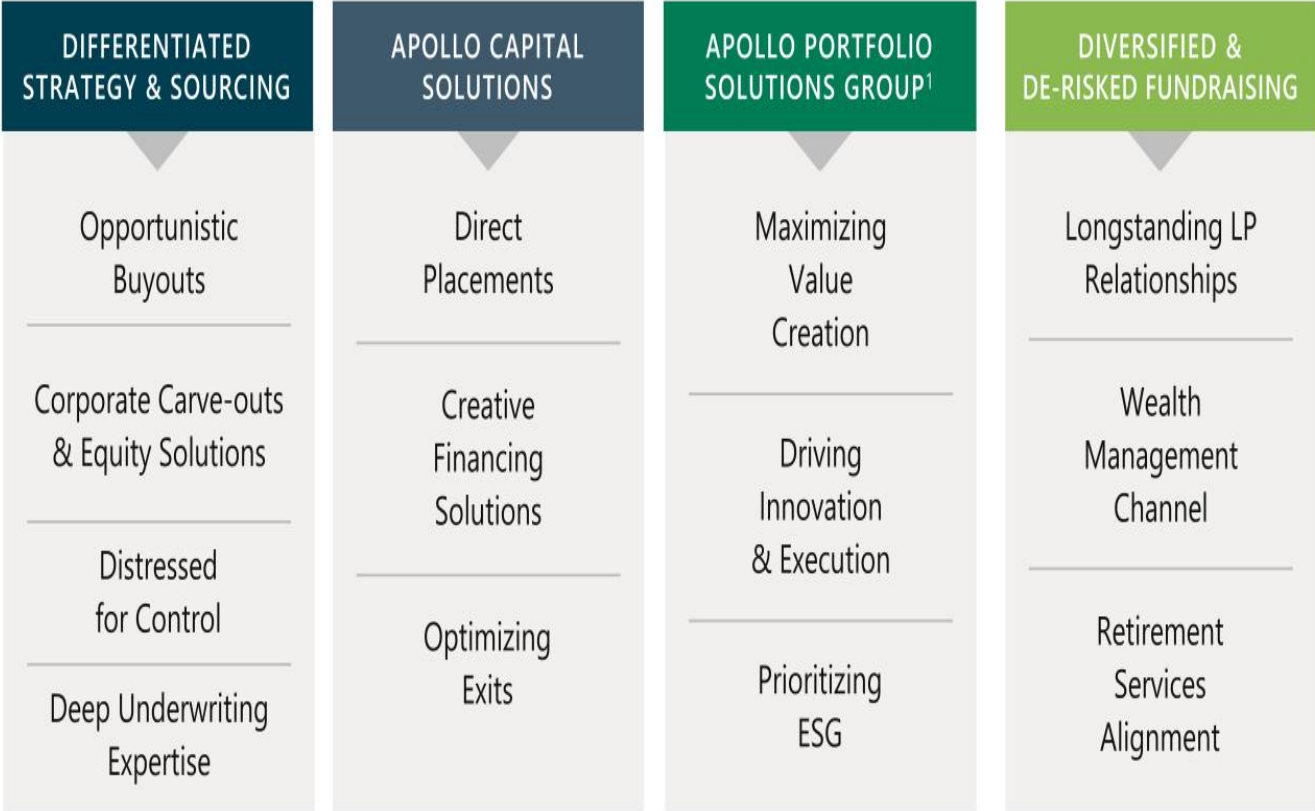

1. Apollo Portfolio Performance Solutions group also known as 'APPS'.
APOLLO INVESTOR DAY 2021

What is Hybrid?

ATTRACTIVE RISK / REWARD

- Flexible capital for corporates, assets, real estate, and insurers
- Deep diligence and underwriting
- Highly structured and/or downside protected
- Opportunistic in dislocation
- Well-positioned in the capital structure

\$47B

ASSETS UNDER
MANAGEMENT

ROBUST PRODUCT
OFFERING TO MEET
GROWING DEMAND

Growth in Hybrid Driven by Market and Capital Inefficiencies

MARKET INEFFICIENCIES

Technicals and Liquidity

"Tourists"

Speed and Complexity

Race to Scale

Event-Driven

CAPITAL INEFFICIENCIES

Banks Exiting Since GFC

Legacy Credit &
Private Equity Allocation Silos

Demand for
Safe Long Duration Alpha

Drawdown Structures

We Have a Robust Portfolio of Mature, Scaling, and Emerging Businesses Poised for Growth

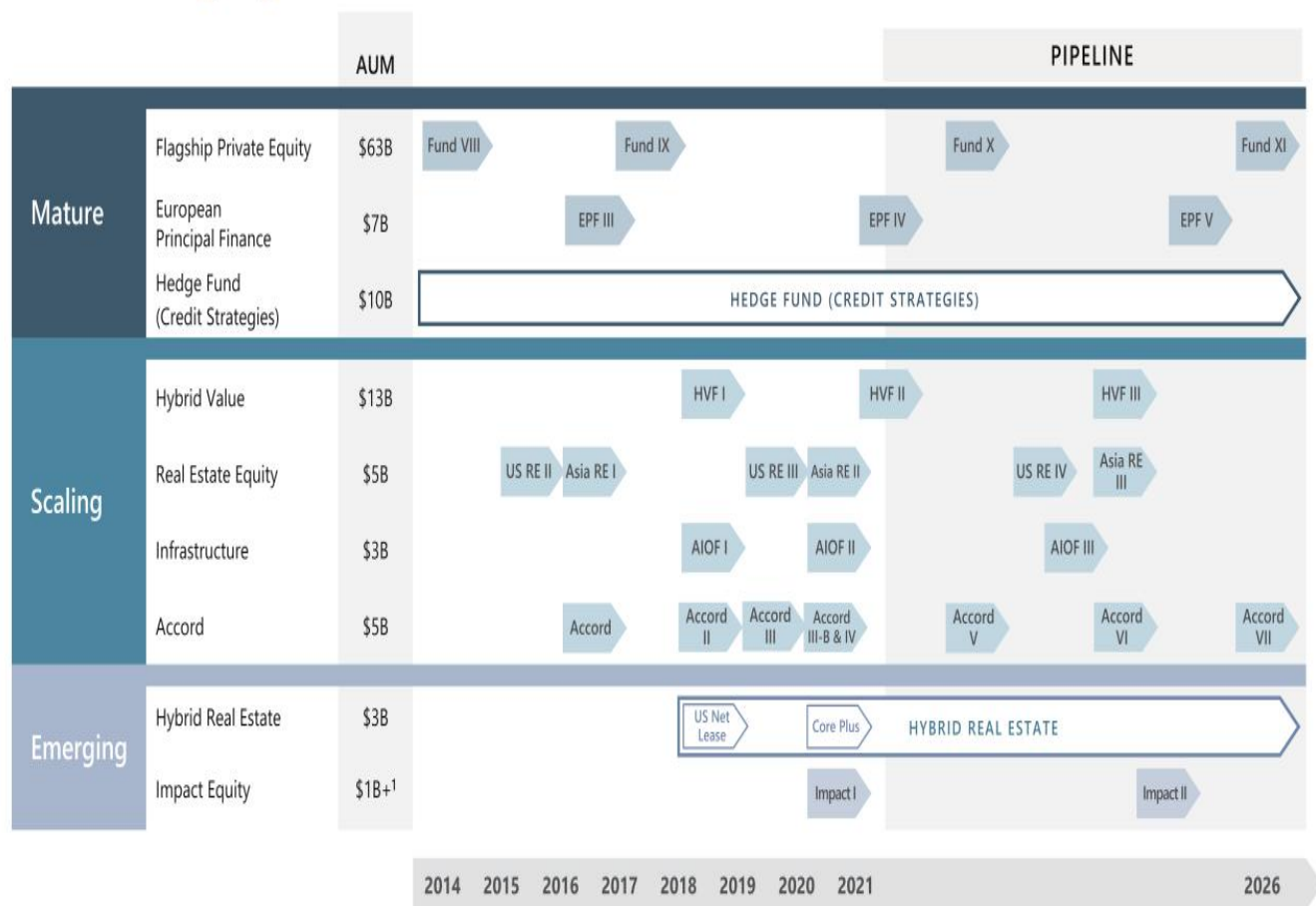

Note: As of June 30, 2021. 1. Targeting \$1B of AUM at final close. Current AUM of \$250M as of June 30, 2021.

What Are We Counting On?

NO HEROIC ASSUMPTIONS...

MATURE

- Similar size for PE franchises
- Normal deployment cadence
- De-risked by strong performance and deep investor relationships

SCALING

- Top quartile performance
- Proven teams
- Categories with huge whitespace and growth opportunities

EMERGING

- Attractive markets and growth dynamics
- Talented new teams
- Ability to scale over time from a modest base

Scaling Strategies Have Large Opportunity for Growth

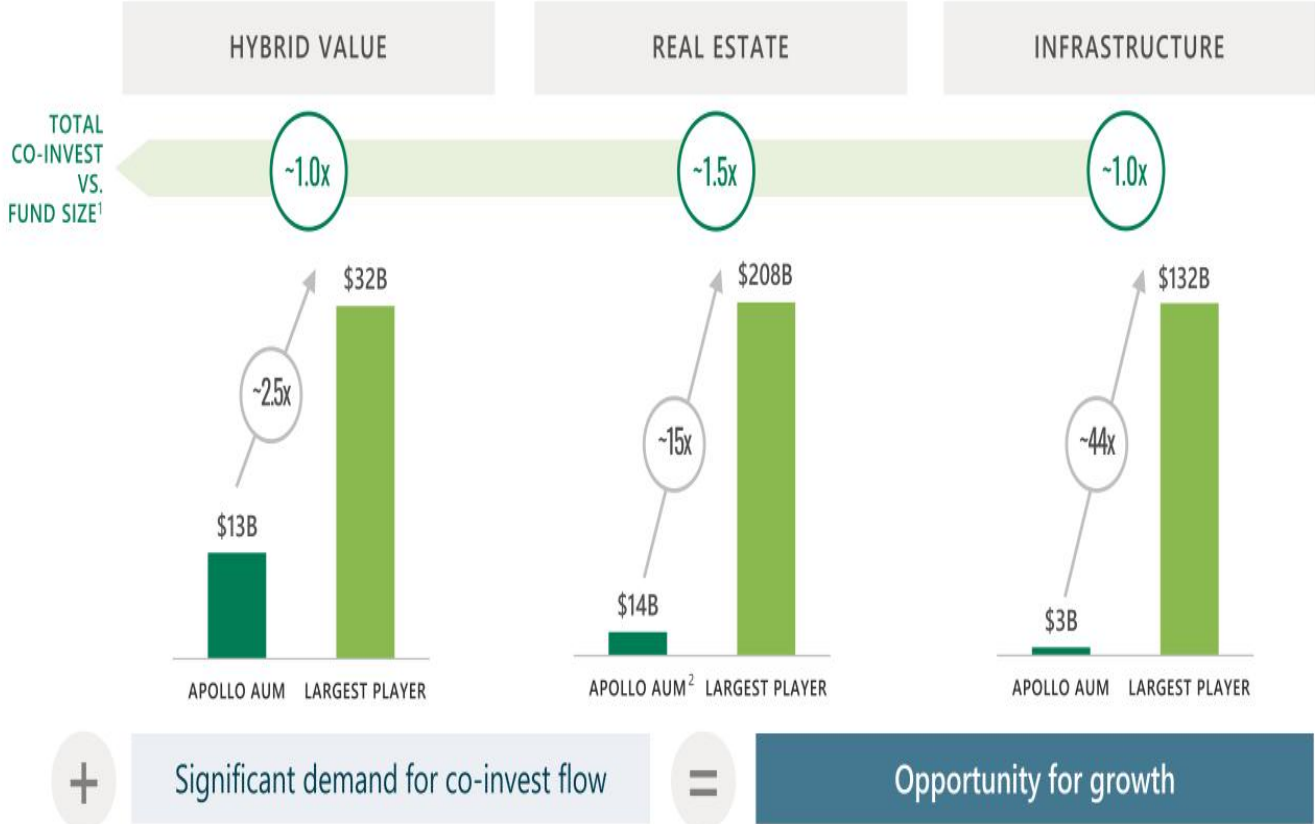

Note: AUM as of June 30, 2021. "Largest Player" represents the investment managers considered by Apollo to be the leading investment managers in their respective markets, and their AUM figures have been obtained from publicly available sources as of August 30, 2021. Information is presented solely as an illustration of comparative AUMs and should not be relied upon as a prediction of Apollo's growth or a forecast of Apollo's AUM in any of the markets presented. Apollo's definition of AUM may differ from the AUM calculations of other investment managers and, as a result, may not be comparable to the AUM presented for these other investment managers. Footnote explanations may be found in presentation endnotes.

We Have De-Risked Our Ability to Scale Rapidly and Successfully





Best-in-class Team

STRONG SENIOR LEADERSHIP WITH 22 YEARS AVERAGE INDUSTRY EXPERIENCE, ~50% AT APOLLO

Equity Leadership

Hybrid Leadership



- | | | | | | | | | | | | | | |
|---------------------------------|------------------------------------|--|-------------------------------------|--|--|---|--|---|--|--|---|--------------------------------------|--|
| MATT NORD
Co-Head, PE | DAVID SAMBUR
Co-Head, PE | AARON MILLER
Head of APPS ¹ | SKARDON BAKER
Head of EPF | PHILIP MINTZ
CIO US & Asia
Real Estate Equity | OLIVIA WASSENAAR
Co-Head of NR | MARC BECKER
Co-Head of Impact | JOANNA REISS
Co-Head of Impact | MATT MICHELINI
Co-Head of Hybrid Value & Head of Asia Pacific | ROB RUBERTON
Co-Head of Hybrid Value | JOHN ZITO
Deputy CIO, Credit | JAMSHID EHSANI
Head of Principal Structured Finance | DYLAN FOO
Co-Head of Infra | GEOFF STRONG
Co-Head of Infra / NR |
|---------------------------------|------------------------------------|--|-------------------------------------|--|--|---|--|---|--|--|---|--------------------------------------|--|

DEEP BENCH OF TALENT SUPPORTED BY ~280 INVESTMENT PROFESSIONALS

Meet the 2021 Rising Stars of Private Equity
The 25 under 40 stars of European private equity 2021

NEW YORK BUSINESS JOURNAL
WOMEN OF INFLUENCE

WSJ PRO
Women to Watch: Female Influencers Making Their Mark on Private Equity

Forbes
30 UNDER 30 FINANCE

Private Equity International
The Future **40**

PHILIP GREUTER
Principal, Private Equity, London



TRACEY GAMBLE
Managing Director, Real Estate Private Equity



TRACY VO
Principal, Private Equity



MONTA OZOLINA
Principal, Private Equity



ANTOINE MUNFAKH
Senior Partner, Private Equity



1. Apollo Portfolio Performance Solutions Team.
APOLLO INVESTOR DAY 2021

Innovating and Evolving While Staying True to Apollo's Core Values

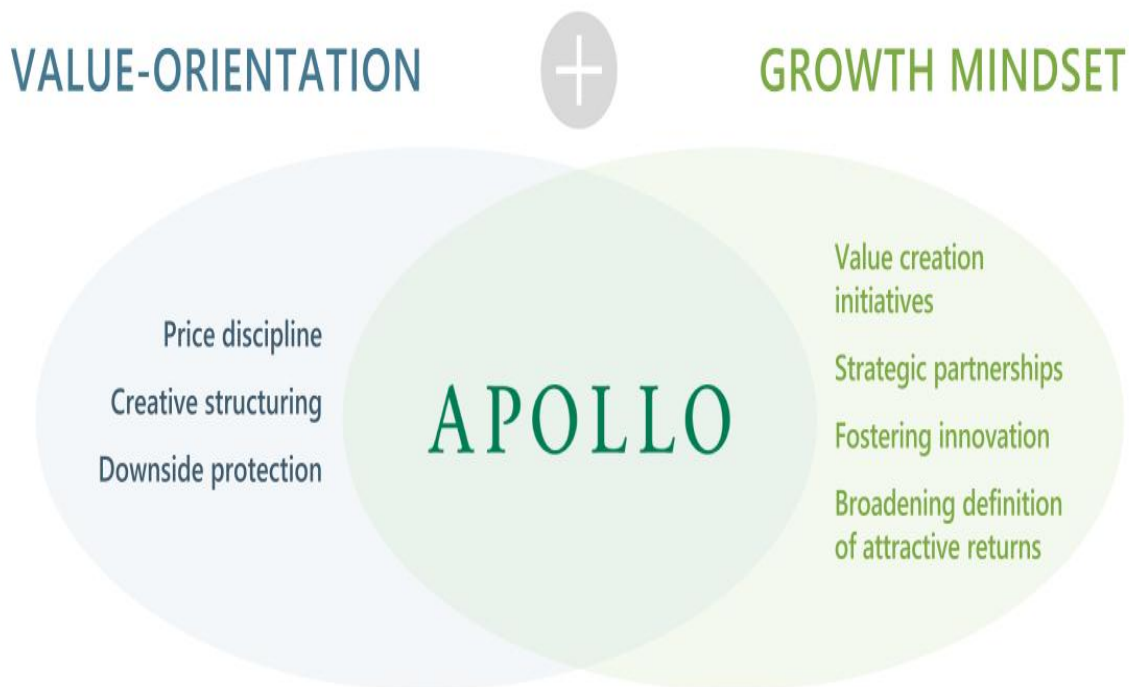

39% Gross IRR

TOP QUARTILE RETURNS¹

Across Apollo's Flagship Private Equity Funds Since Inception

Note: Returns as of June 30, 2021. 1. As provided by Cambridge Associates, as of Q1 2021. Please refer to the Appendix pages for important information on benchmark definitions.

Powered by Our Integrated Platform

INTEGRATED PLATFORM BENEFITS

- ✓ Collaborative Culture
- ✓ Institutional Expertise
- ✓ One-Firm Mindset

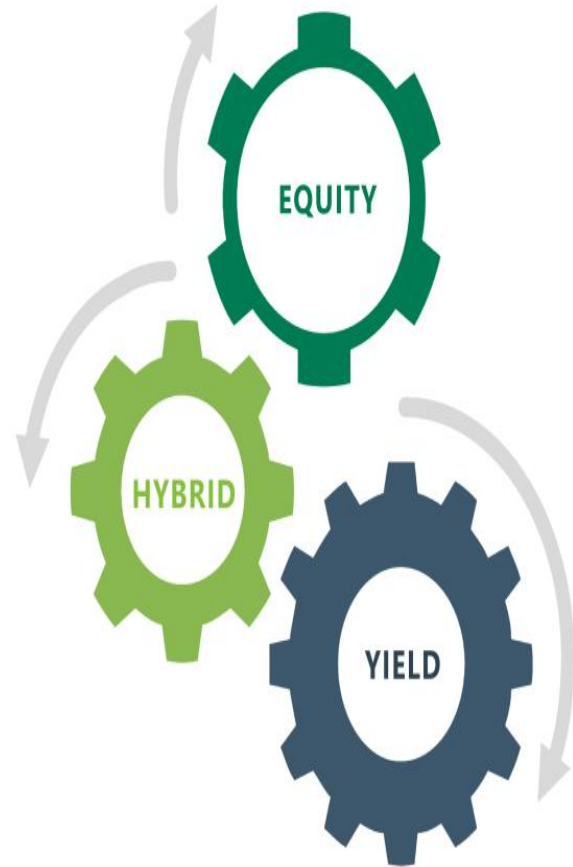



Industry-Leading Track Records Across Our Business

APOLLO STRATEGY	STRATEGY INCEPTION	NUMBER OF VINTAGES	GROSS IRR ¹
Flagship Private Equity	1990	9	39%
European Principal Finance	2008	3	19%
Infrastructure	2018	2	26%
Hybrid Value	2019	2	29% ²
Accord	2017	4	22%
Hedge Fund (Credit Strategies)	2011	Evergreen	12% ³

1. Represents strategy-level Gross IRRs as of June 30, 2021. 2. Gross IRR representative of HVF I only. 3. Gross ROE as of June 30, 2021.

Focus on Modernization



Apollo Portfolio Performance Solutions ("APPS") Team

Value creation at portfolio companies via tech



MOTIVE PARTNERS

Specialist PE firm focused on FinTech investments



25madison

Leading Venture Studio & Innovation Hub

Front Office Technology & Innovation Team

Implements strategies across our platform

FIGURE

Developer of blockchain-enabled solutions

Upside from Innovation and Capitalizing on Growing Whitespace

EXPERIENCE IN EMERGING AREAS OF INTEREST VIA EXISTING PRODUCTS...

...DRIVES POTENTIAL DEDICATED PRODUCT DEVELOPMENT



Spartan Energy Acquisition Corp.

Spartan Acquisition Corp. II

Sunlight Financial

APOLLO | Strategic Growth Capital



GROWTH



Continuation vehicle



Growth lending fund finance



GP SOLUTIONS



TAKKION



ENERGY TRANSITION



MOTIVE PARTNERS

FIGURE



FINTECH

Key Takeaways for Our Equity & Hybrid Business

NO BIG ASSUMPTIONS...

1

Maintaining an industry-leading position in mature franchises and Flagship Private Equity

2

Significant growth opportunity for scaling strategies, especially in Hybrid

3

Upside from whitespace opportunities

**INVESTOR
DAY 2021**

Retirement Services Overview

SCOTT KLEINMAN

Co-President



Retirement Services is a Highly Stable Growth Business

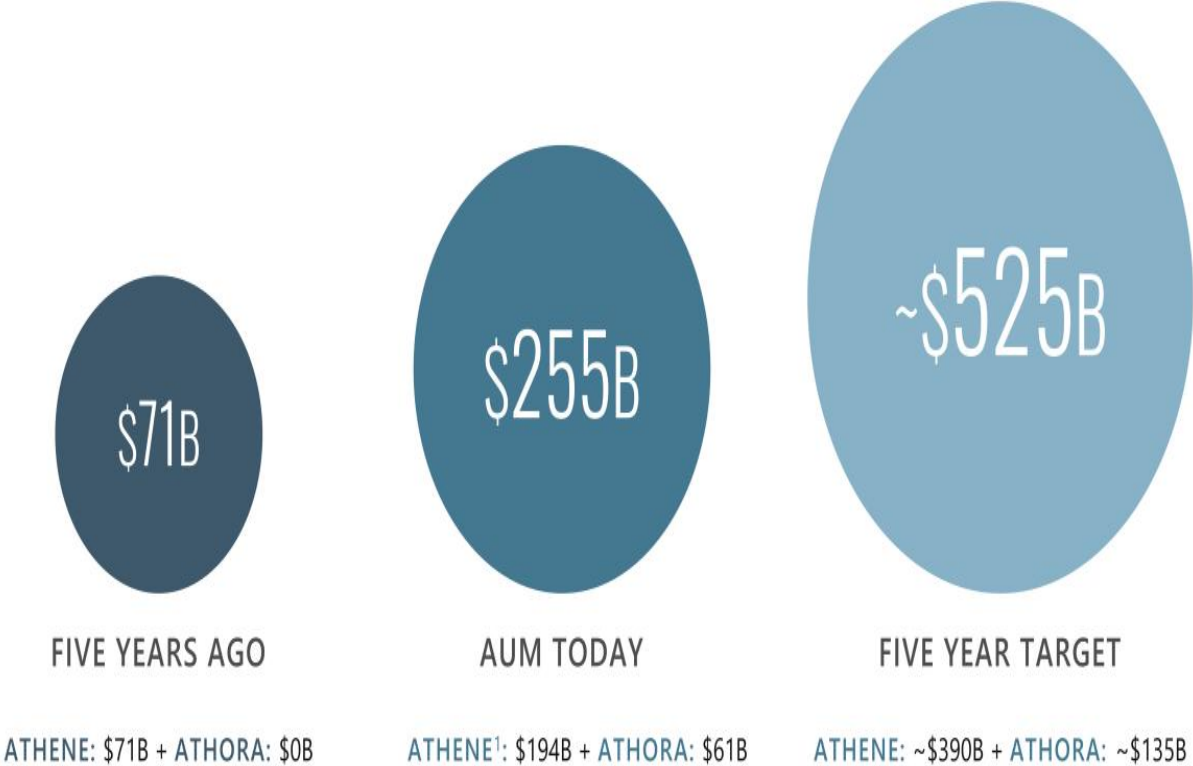

Note: AUM Five Years Ago as of December 31, 2016. 1. Includes \$44.6 billion of gross assets related to Athene Co-Invest Reinsurance Affiliate 1A Ltd. and \$2.1 billion of unfunded commitments related to Apollo/Athene Dedicated Investment Program.

What is Retirement Services?

WHAT RETIREMENT SERVICES IS

Spread business generating investment income for retirees

- ✓ Simple
- ✓ Stable
- ✓ Predictable
- ✓ Growing

SPREAD RELATED EARNINGS (SRE)

WHAT RETIREMENT SERVICES IS NOT

Greater uncertainty and tail risk

- ✗ Variable Annuities
- ✗ Long-Term Care
- ✗ Structured Settlements
- ✗ Property & Casualty
- ✗ Traditional Life Insurance

Retirement Services Raises AUM for Apollo Across All Channels, Just Like Our Traditional Fundraising Activities

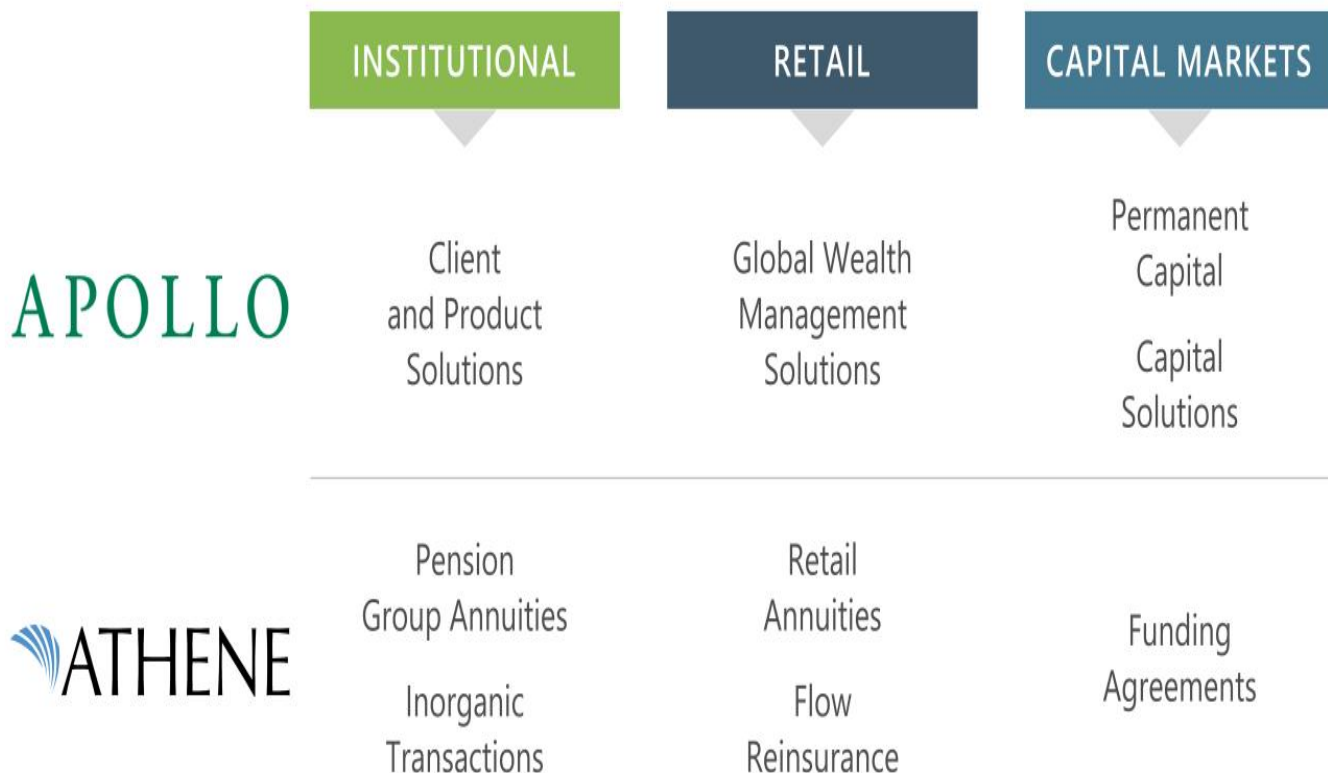

Key to Success in Retirement Services is the Ability to Generate Yield

ILLUSTRATIVE IMPACT OF APOLLO'S ASSET MANAGEMENT CAPABILITIES

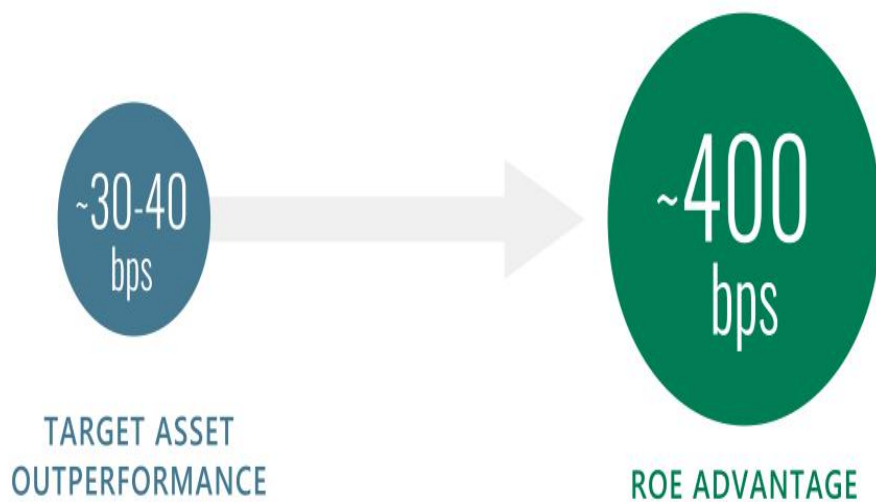

Apollo's Yield franchise sources high-quality, alpha-generating credit assets to drive profitability







Our Retirement Services Footprint is Going Global, and the Market Opportunity is Enormous



Apollo's ~\$260B AUM today represents less than 2% of the \$20T+ total addressable market

Footnote explanations may be found in presentation endnotes.
APOLLO INVESTOR DAY 2021

Secular Tailwinds Will Continue to Drive Retirement Services

DEMOGRAPHICS TAILWINDS	NEED FOR RETIREMENT INCOME	SHIFT FROM DB TO DC	INDUSTRY RESTRUCTURING
 <p>1.5 Billion people aged 65+ in the world by 2050; 2x 2019¹</p>	 <p>10-YEAR TREASURY YIELD²</p>	 <p>15% of US Private Industry workers with a defined benefit plan; 64% with access to a defined contribution plan³</p>	<ul style="list-style-type: none"> ↓ Low interest rates driving down profitability  Legacy liability issues  Increasing pressure from shareholders  Regulatory change

1. US private-sector workers per United Nations Department of Economic and Social Affairs. 2. Federal Reserve Economic Data as of October 15, 2021. 3. As of March 2020, National Compensation Survey, US Bureau of Labor Statistics.

Apollo and its Clients Have Been Beneficiaries of Secular Change

PERSISTENTLY LOW YIELDS HAVE DRIVEN MANY PEERS TO RESTRUCTURE

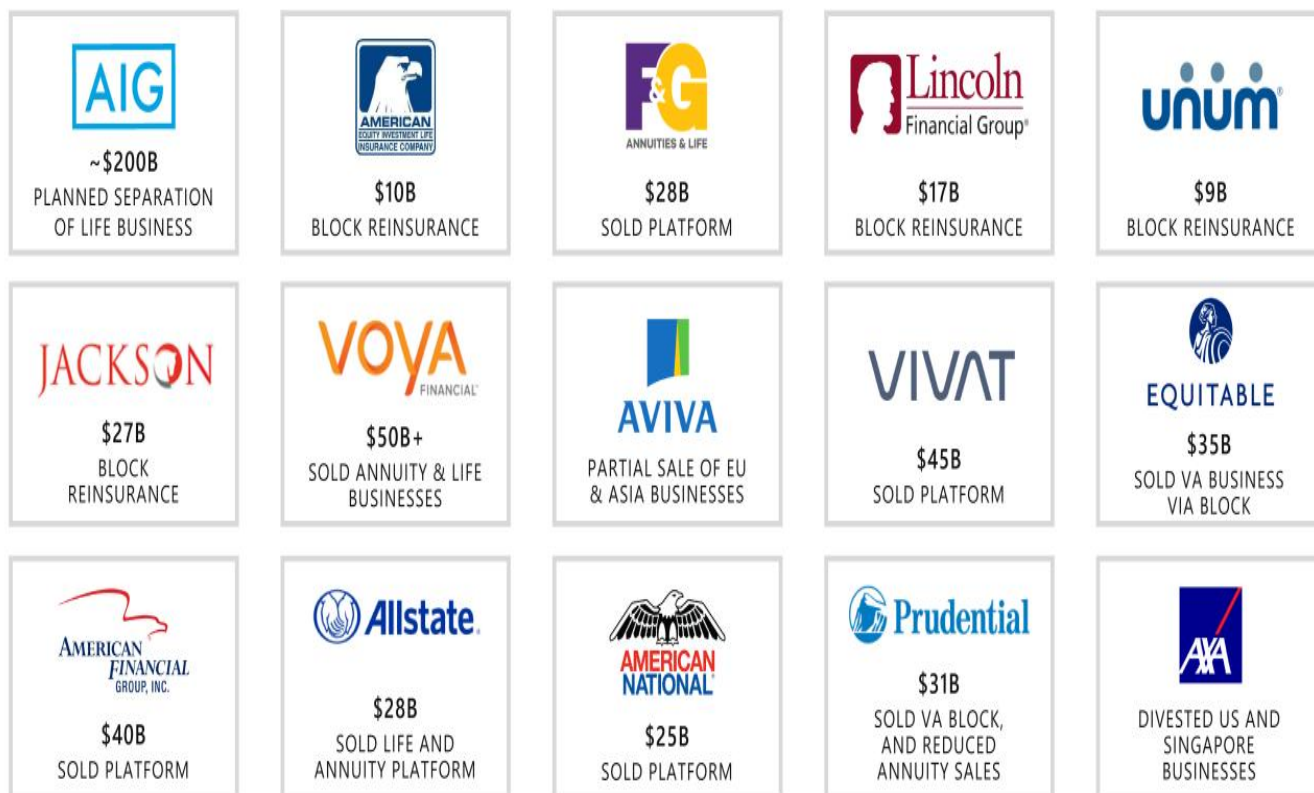

Note: Size represents the assets backing the liabilities.

APOLLO INVESTOR DAY 2021

145

Strong Track Record of Being a Solutions Provider

WITH A FOCUS ON GROWTH THAT IS CLOSELY ALIGNED TO PROFITABILITY



12 transactions over 12 years totaling \$180B of AUM

Significant Growth Expected Over the Next 5 Years



AUM¹ & NORMALIZED SRE GROWTH (\$B)

AUM GROWTH (\$B)



1. Includes \$44.6 billion of gross assets related to Athene Co-Invest Reinsurance Affiliate 1A Ltd. and \$2.1 billion of unfunded commitments related to Apollo/Athene Dedicated Investment Program. 2. As reported by Athene, represents adjusted operating income (excludes AOG investment, taxes, and long-term incentive plan compensation) and reflects 11% long-term alternative investment returns.

Validation of the Path We've Chosen is All Around Us

IF RETIREMENT SERVICES IS TRULY A 'LESS VALUABLE' BUSINESS, WHY ARE OTHERS PILING IN?



Blackstone Investor Day
SEPTEMBER 2018



Carlyle Investor Day
FEBRUARY 2021



KKR Investor Day
APRIL 2021



Ares Investor Day
AUGUST 2021

Insurance Solutions is a natural extension of our credit business

Brookfield Investor Day
SEPTEMBER 2021

Right Capabilities, Right Team, at the Right Time

	OUR APPROACH	COMPETITORS' APPROACH
Experience	<ul style="list-style-type: none"> • 12+ years with Athene & 6 years with Athora 	<ul style="list-style-type: none"> ✗ No historical relationship
People	<ul style="list-style-type: none"> • 450+ FIG and Insurance professionals supported by integrated platform 	<ul style="list-style-type: none"> ✗ Often covered by single, siloed team
Alignment	<ul style="list-style-type: none"> • Full alignment upon merger close 	<ul style="list-style-type: none"> ✗ Partial alignment
Capital Raising	<ul style="list-style-type: none"> • Leader in raising vanilla liabilities with minimal uncertainty and tail risk 	<ul style="list-style-type: none"> ✗ Chasing growth by acquiring complex liabilities & platforms at a premium
Origination of Appropriate Assets	<ul style="list-style-type: none"> • Significant investment in front-end 	<ul style="list-style-type: none"> ✗ Fewer capabilities in relevant risk / return assets

Imitation ≠ Replication

Massive Landscape of Upside Opportunities

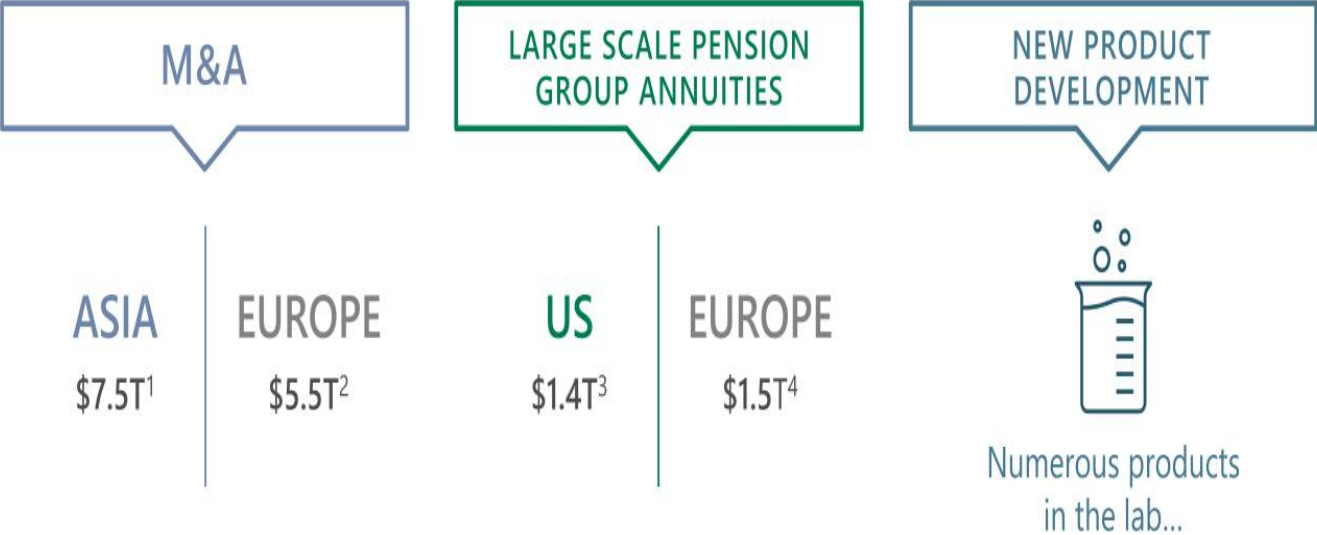

Inorganic growth is a choice - growth determined by available assets, not liabilities

Footnote explanations may be found in presentation endnotes.
APOLLO INVESTOR DAY 2021

INVESTOR
DAY 2021

Athene

JIM BELARDI

Athene Chairman, Chief Executive Officer, & Chief Investment Officer



Athene's Business Is Simple

What
does
Athene
do?

1

ATHENE
GENERATES
INFLOWS

By **providing a suite of principal protected investment products** to the retirement market

2

INVESTS
WITH
APOLLO

In a **high-quality resilient portfolio** optimized for return

3

KEEPS SPREAD
ABOVE
FUNDING COST

Resulting in **strong growth** in spread related earnings

Athene Has Numerous Competitive Advantages



Differentiated asset management through Apollo



Ability to source low-cost funding through various business channels



Highly efficient and scalable operating structure



Highly-rated, strong, and conservatively managed balance sheet with no legacy liability issues



Access to third-party capital through Apollo

Athene's Team is One of the Industry's Strongest

EXPERIENCED SENIOR LEADERSHIP



**JIM
BELARDI**

Chief Executive Officer &
Chief Investment Officer



**BILL
WHEELER**

President



**GRANT
KVALHEIM**

CEO & President,
Athene USA



**MARTY
KLEIN**

EVP,
Chief Financial Officer

IN ADDITION TO...

**1,350+ TEAM MEMBERS
ACROSS 3 COUNTRIES**

DEEP BENCH OF TALENTED EXECUTIVES ACROSS THE BUSINESS



**SEAN
BRENNAN**

EVP,
Pension Risk
Transfer & Flow
Reinsurance



**KRISTI KAYE
BURMA**

EVP,
Human
Resources



**KATIE
DALY**

EVP,
Corporate
Development



**MIKE
DOWNING**

EVP,
Chief Actuary



**RANDY
EPRIGHT**

EVP,
Chief Information
Officer



**JOHN
GOLDEN**

EVP,
General Counsel



**CHRIS
GRADY**

EVP,
Retail Sales



**DOUG
NEIMANN**

EVP,
Chief Risk Officer



**CHRIS
WELP**

EVP,
Insurance
Operations

Athene's Advantages Drive Value Creation

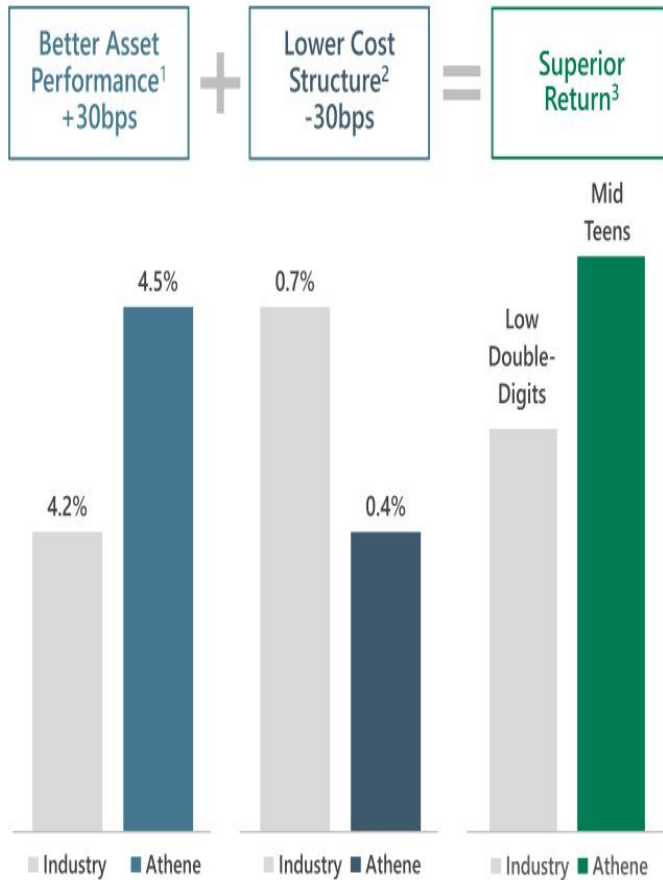

Peers represent a weighted average of AEL, AIG, AFG, FGL, LNC, MET, PRU, and PFG for the 5 years 2016 to 2020. Source: SNL Financial, Company Filings. Footnote explanations may be found in presentation endnotes.

Athene Originates Low-Cost, Long-Dated Funding

SIMPLE RETIREMENT SAVINGS PRODUCTS WITH STRUCTURAL FEATURES THAT INCREASE STABILITY

9 Year
Weighted Average Life of Funding

~75%
Of Funding Carries a Withdrawal Penalty or Cannot be Withdrawn

2.2%¹
Average Cost of Funds on New Business

- ✓ Spread-Based
- ✓ Conservatively Underwritten
- ✓ Very Limited Tail Risk

DIVERSIFIED LIABILITY PORTFOLIO

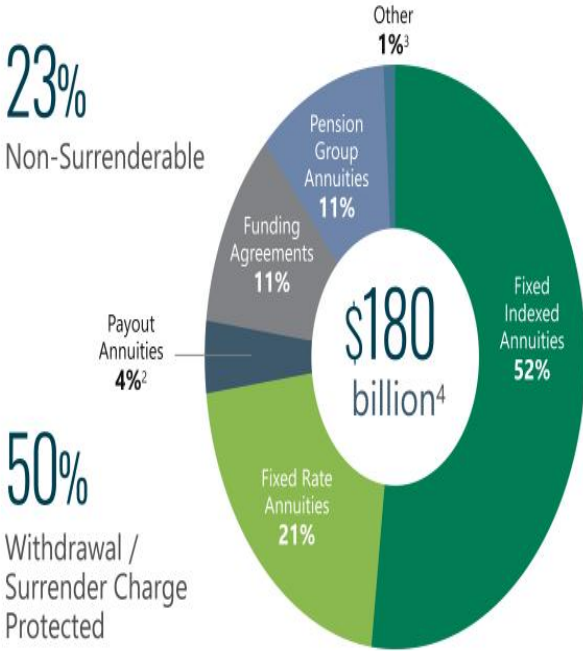

1. 2021 YTD as of June 30, 2021. Expected level lifetime cost of liabilities including policyholder benefits, commissions, and maintenance expenses but excluding taxes, investment fees, and overhead expenses. 2. Includes Single Premium Immediate Annuities, Supplemental Contracts and Structured Settlements. 3. Other primarily consists of the AmerUs Closed Block liabilities and other life reserves. 4. Gross reserve liabilities includes reserves associated with the ACRA noncontrolling interest as of June 30, 2021.

Athene Has Various Channels From Which to Generate Inflows

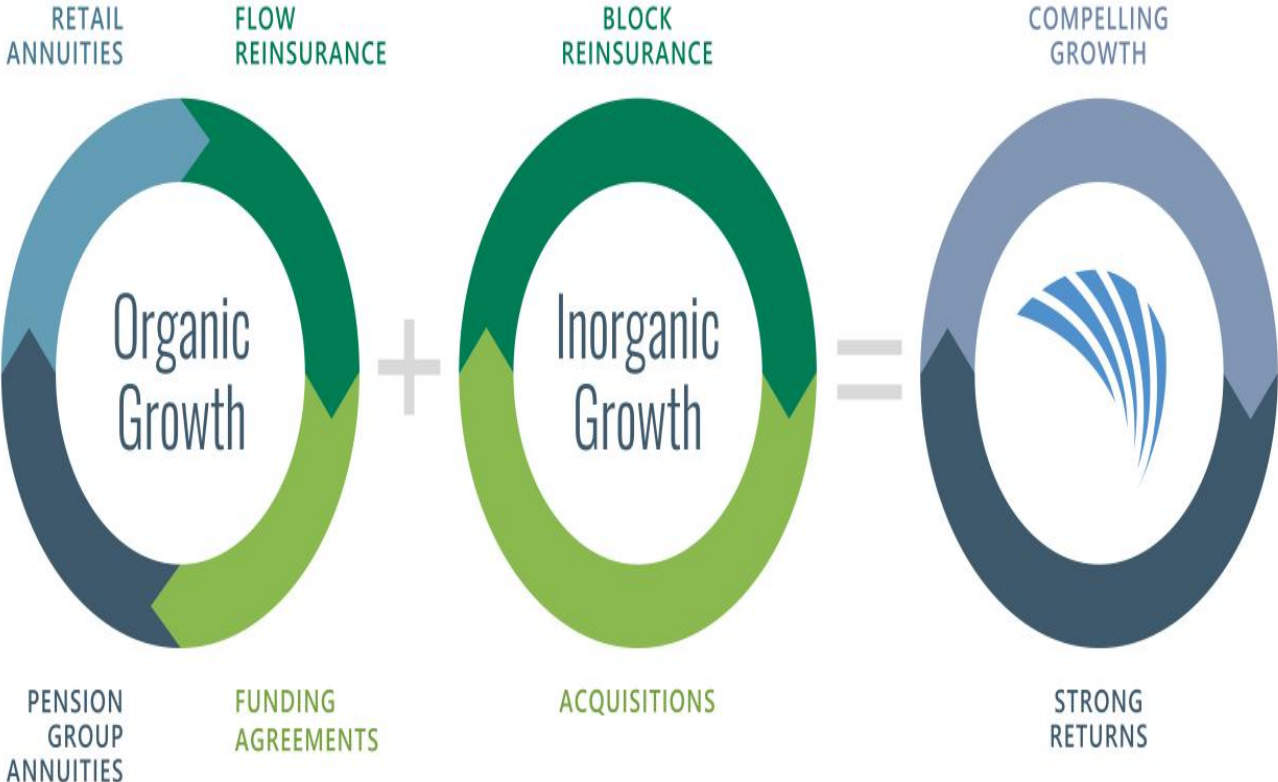

Organic Growth Capability is Market Leading

ORGANIC INFLOWS BY CHANNEL (\$B)

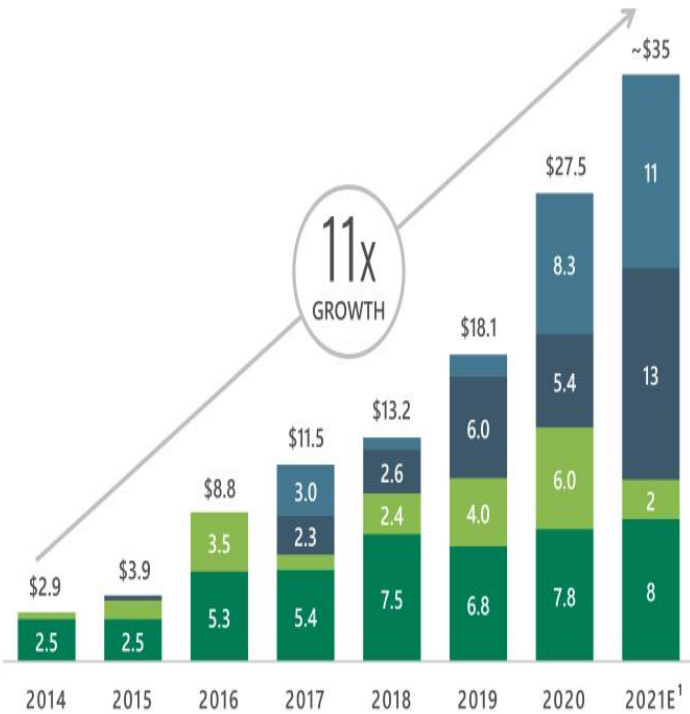

Athene is a Market Leader Across Organic Inflow Channels

<p>RETAIL ANNUITIES</p> <p>#1 Market Share for Fixed Index Annuity Issuance²</p>	<p>FUNDING AGREEMENTS</p> <p>#1 Market Share in 2021 YTD³</p>
<p>PENSION GROUP ANNUITIES</p> <p>#1 Market Share in 2020 and 2021 YTD^{2,4}</p>	<p>FLOW REINSURANCE</p> <p>#1 Market Share in 2020⁵</p>

1. Forecasted organic inflows by channel, subject to change and numbers may not sum due to rounding. 2. LIMRA data for the six months ended June 30, 2021. 3. For the six months ended June 30, 2021. Funding agreements are comprised of funding agreements issued under our FABN and FABR programs, funding agreements issued to the FHLB and long-term repurchase agreements. 4. LIMRA data for full year 2020. 5. Source: Insurance Company US Statutory Annual Statements.

The Opportunity Set Is Vast

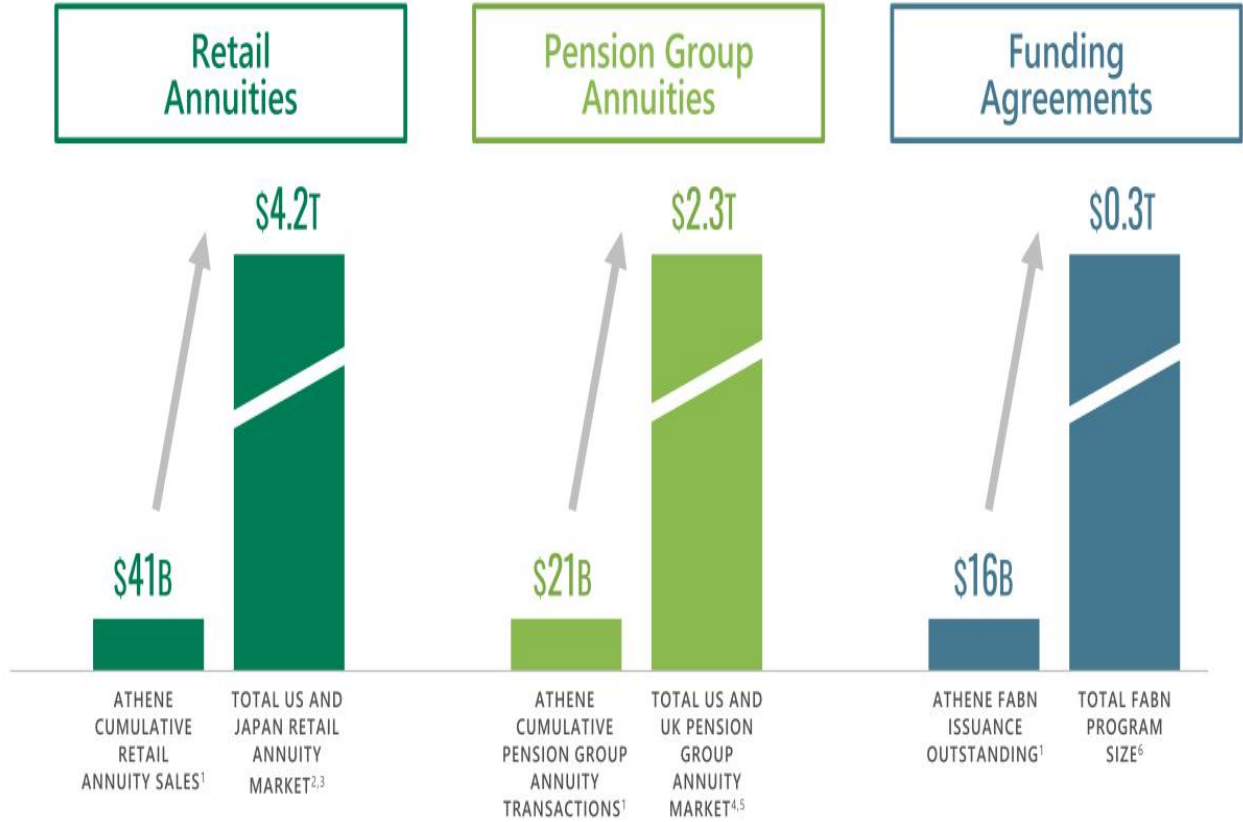

Note: Not shown to scale for illustrative purposes. Footnote explanations may be found in presentation endnotes.

Retail Annuities

Business Highlights

- Athene is a leading fixed indexed annuity issuer
- Broad range of products for various market cycles and retirement strategies, with focus on fixed indexed annuities
- Product differentiation through custom index construction

RETAIL INFLOWS BY DISTRIBUTION¹

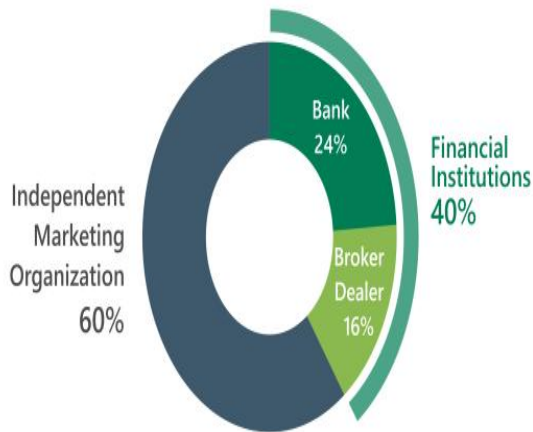

1. Cumulative percentage, 2YR trailing (2Q21-2Q19).

Retail Annuity Inflows (\$B)

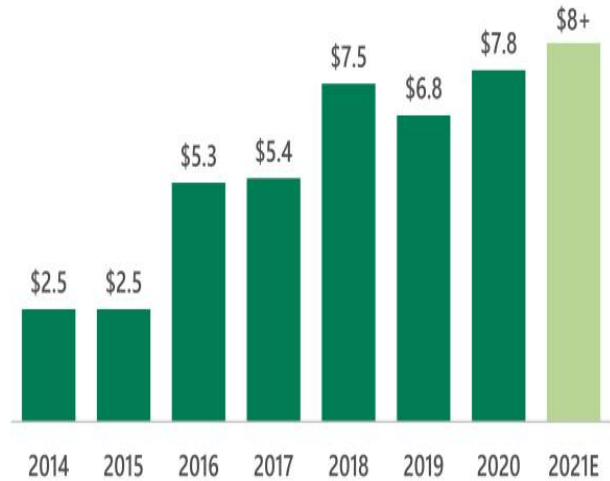

KEY DRIVERS:

- Tailored annuity offerings capitalize on secular demand for yield and income protection for retirees
- Expanding retail distribution within broader financial institutions channel (i.e. product sold through banks and broker-dealers)

Pension Group Annuities

Business Highlights

- Entered the pension group annuity business in 2017 and quickly grew into a market leader
- Through several signature transactions, has become known as a partner of choice for blue-chip corporate pension plan sponsors

Signature Transactions



\$2.6 BILLION
2019



\$4.9 BILLION
2021

WHAT IS A PENSION GROUP ANNUITY?

- 1 Occurs when a defined benefit pension plan sponsor transfers some or all of the plan's liabilities to another company
- 2 That company issues a group ("bulk") annuity which provides benefit continuity for all the pensioners within the plan

Pension Group Annuity Inflows (\$B)

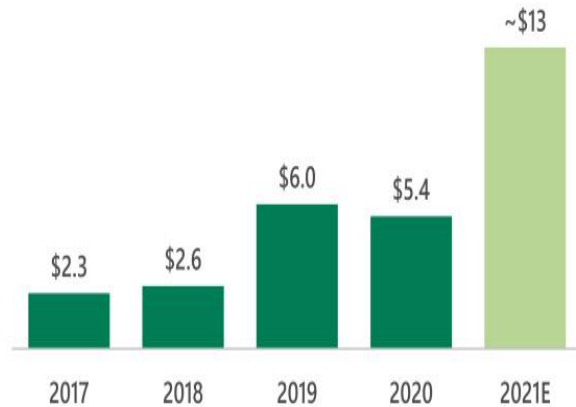

KEY DRIVERS:

- Long-term secular shift by corporations away from managing pension assets internally
- Provides simplicity and consistent income to retirees while offering increased efficiency to corporations and plan sponsors

Funding Agreements

Business Highlights

- Athene maintains issuing capabilities across currencies in North America and European markets
- While at SunAmerica in the 1990s, Jim Belardi pioneered the development of the Funding Agreement Backed Note (FABN), which has since grown into a ~\$250 billion market

WHAT IS A FUNDING AGREEMENT?

- 1 Traditional fixed income investors purchase a fixed income investment (effectively a note or bond), and the issuer guarantees a fixed or floating rate of return over a certain tenor
- 2 The issuer re-invests the amount of the funding agreement and seeks to earn more than the cost of the funding agreement
- 3 Funding agreements are priced based on market demand and the credit rating of the issuer

Funding Agreement Inflows (\$B)¹

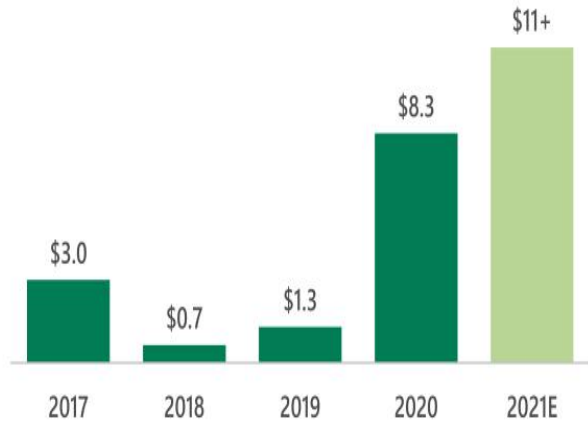

KEY DRIVERS:

- Increasing demand by institutions given the relatively higher yield profile of funding agreements vs. similarly-rated corporate debt
- Strong demand and improved funding costs for Athene FABNs driven by continued credit rating improvements

1. Funding agreements are comprised of funding agreements issued under our FABN and FABR programs, funding agreements issued to the FHLB and long-term repurchase agreements.

Flow Reinsurance

Business Highlights

- Ongoing priority to diversify counterparty relationships across geographies and product areas
- During 2020, built a reputation of strength in the market as a partner of choice, supporting counterparties when others chose to conserve capital
- Recent expansion into Japanese market with two key partnerships

HOW DOES FLOW REINSURANCE WORK?

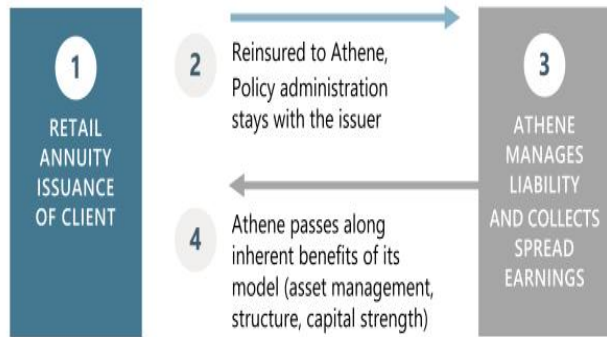

Flow Reinsurance Inflows (\$B)

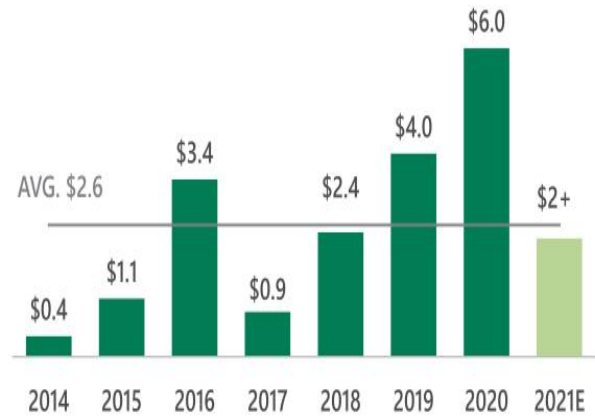

KEY DRIVERS:

- Demand for capital efficiency / risk management from other annuity issuers
- Changes in market pricing conditions and counterparty behavior can cause fluctuations

Athene Generates Significant Capital to Fund Growth

ATHENE IS TODAY, AND HAS ALWAYS BEEN, MASSIVELY CAPITAL GENERATIVE

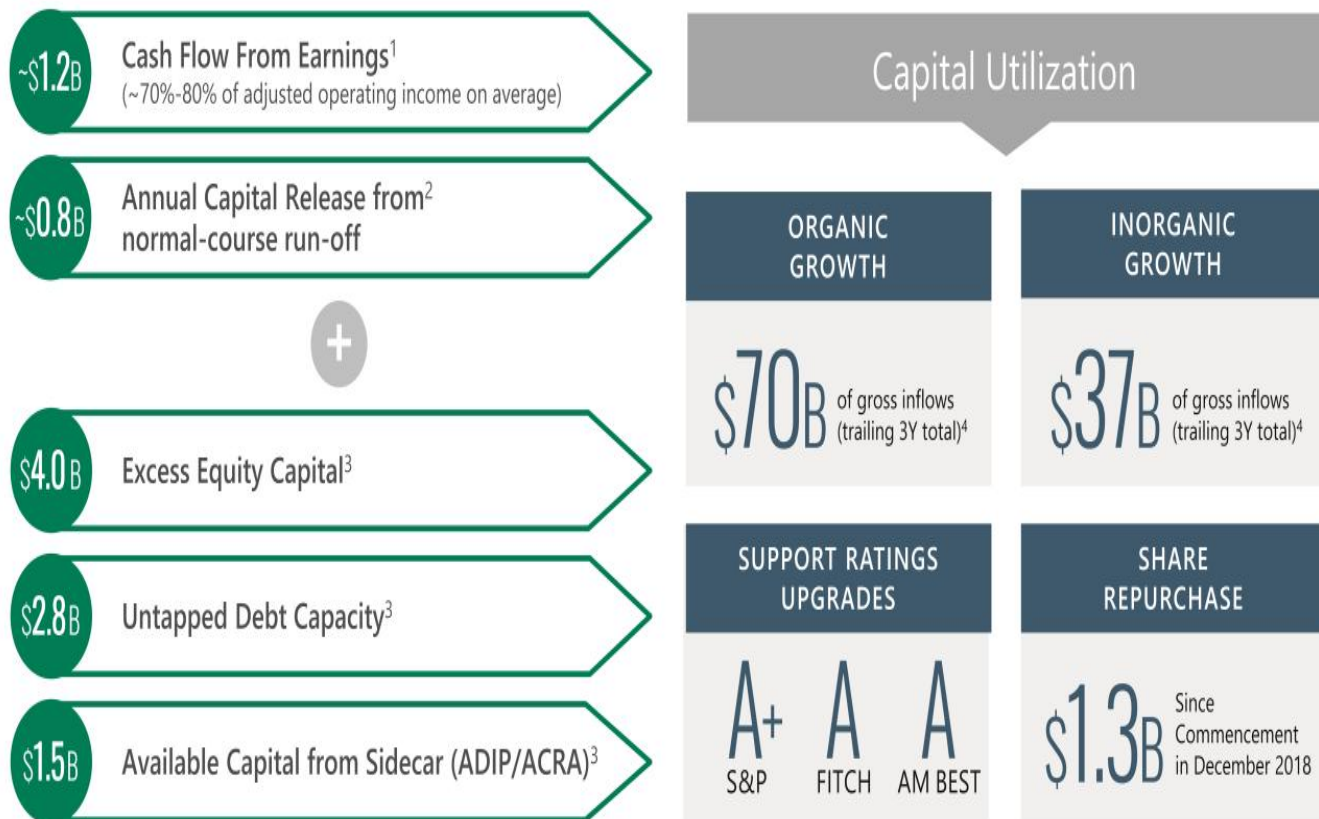

Note: Data as of June 30, 2021. Footnote explanations may be found in presentation endnotes.
APOLLO INVESTOR DAY 2021

Sidecar Capital Augments Our Capital Efficiency and Profitability

Apollo/Athene dedicated investment program (ADIP) is a win-win for Athene and Limited Partners

WHAT IS ADIP?

- **\$3.2 billion On-Demand Capital Pool** (Closed in 2019)
- **\$1.7 billion of capital deployed** to date to support Athene's growth
- 3-5 year investment period
- 13-14% unlevered gross target return to LPs

SUPPORTS GROWTH

Investors earn attractive spread economics on **current ~\$28 billion of assets**, with potential to exceed \$60 billion when fully-deployed

ENHANCES PROFITABILITY

Athene earns up to ~15 basis point fee on all liabilities ADIP supports



~300 basis point ROE enhancement on business Athene retains

ADIP is a structural part of how we operate

High-Quality Asset Portfolio Optimized for Yield Generation

Investment Philosophy

- Target higher and sustainable risk-adjusted returns with opportunistic approach to liquidity and structuring risk
- No need to stretch for yield given long-dated liability profile and low cost of funding
- Dynamic asset allocation to take advantage of market dislocations
- Differentiation driven by proprietary asset origination and greater asset expertise

KEY ATTRIBUTES

94%
AFS FIXED MATURITY
SECURITIES RATED
INVESTMENT GRADE¹

- ✓ RESILIENT
- ✓ HIGH GRADE
- ✓ STRESS TESTED

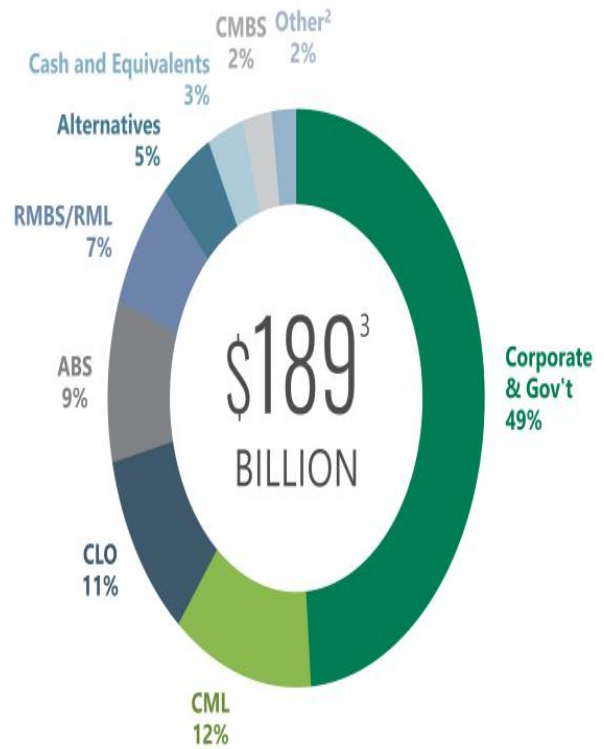

1. Investment Grade means designated NAIC categories 1 and 2 for AFS securities as of 6/30/21. 2. "Other" includes ADG units, Accrued Income, Equity Securities, Policy Loans, and Short Term Investments. 3. Gross invested assets includes investments associated with the ACRA noncontrolling interest.

Risk Management is Embedded in Everything We Do

MANAGE ATHENE'S RISKS SUCH THAT IT CAN GROW PROFITABLY ACROSS VARIOUS MARKETS



ATHENE'S RISK MANAGEMENT PRIORITIES

- Robust risk management framework and procedures underpin focus on downside protection
- Risk strategy, investment, ALM and liquidity compliance policies at the board and management levels
- Stress testing plays a key role in defining risk appetite, with tests performed on both sides of the balance sheet

Committed to transparency by publishing annual stress test: **latest edition available October 19, 2021**

We Run Our Business Aligned with Our Risk Appetite and in Consideration of Historical Events

	ATHENE ASSUMPTIONS		SAMPLE HISTORICAL RECESSION DATA				
	Baseline Recession Scenario	Deep Recession Scenario	1990	2001	2008	Euro 2016	COVID 2020 ¹
10 Yr US Treasury Yield	Down 60% (e.g. ~70bps)	Down 83% (e.g. ~120bps)	Up 4%	Down 21%	Down 43%	Down 84% ²	Down 68%
Absolute Spreads (BBB / B)	279bps / 802bps ³	636bps / 1,789bps ³	240bps / NA	318bps / 1,083bps	642bps / 1,913bps	317bps / 876bps	474bps / 1139bps
Equity Markets⁴	(34%)	(49%)	(20%)	(30%)	(49%)	(12%)	(34%)
Fixed Income Defaults (BBB / B)	0.7% / 12.9%	1.4% / 13.7%	0.3% / 13.7%	1.0% / 9.2%	0.9% / 7.1%	0.0% / 2.4%	0.1% / 6.2%
Housing Price (Peak to Trough)	(3%)	(27%)	(3%)	No Decline	(33%)	No Decline	No Decline
Est. Net Impact on Excess Capital⁵	\$0.0	(\$0.6)	 Net impact represents the total estimated stress impact in a recession, offset by 2020 STAT earnings and mgmt. actions				

Source: Spread – JPMorgan US Liquid Index (JULI) BBB Spread (Libor) for BBB and JPMorgan Domestic HY Spread to Worst for B, except for 1990 and Euro 2016. For 1990: Federal Reserve Bank of St. Louis, Moody's Seasoned Baa Corporate Bond Yield Relative to Yield on 10-Year Treasury Constant Maturity BAA10Y as JP Morgan indices were not available. For Euro 2016: JPMorgan US Liquid Index (JULI) BBB Spread (Treasury) on Feb 10th 2016 for BBB and JPMorgan Developed Market Single B HY Spread to Worst on Feb 9th 2016 for B. FI Default – For COVID 2020: Moody's Monthly Default Report from Moody's Investor Services. For historical experiences: Moody's Annual Default Study, Corporate Default and Recovery Rates. There is no guarantee that Athene will be able to replicate actual historical recession experience under current market conditions or during future recessions. Footnote explanations may be found in presentation endnotes.

Minimal Credit Losses Historically and During COVID-19

DISCIPLINED RISK APPETITE

- Risk appetite is to **avoid a credit rating downgrade** in a typical “recession” scenario, and maintain an investment grade credit rating in a “deep recession” scenario like 2008/2009
- Risk management is **deeply embedded in all business decisions** and processes
- The enterprise risk appetite is established using stress testing and is **cascaded to the business** through risk limits
- Constant **communication with rating agencies** and reinsurance counterparties

HISTORICAL CREDIT LOSSES¹

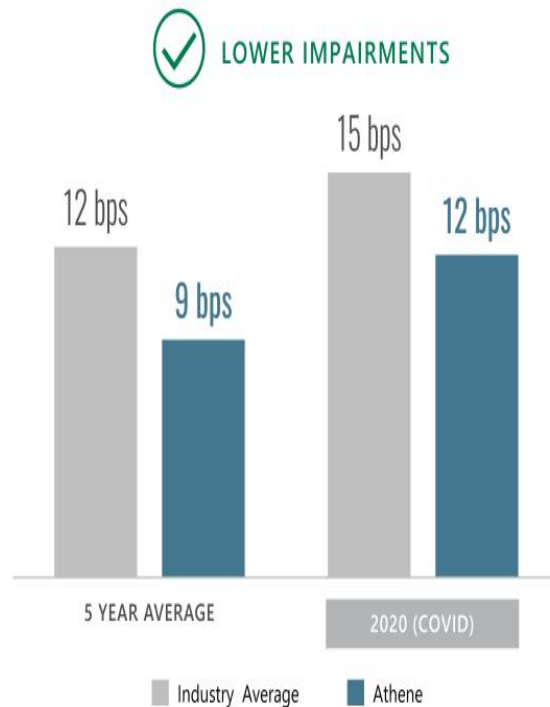

1. Peer U.S. statutory impairments per SML Financial, average includes AEL, AIG, AMP, BHF, EQH, FG, LNC, MET, PFG, PRU, VOYA and Transamerica. For Athene, U.S. statutory data adjusted to include impairments and assets in Bermuda. Linked presentations are not incorporated by reference.

Key Takeaways

1

Athene has a simple spread business model

2

Athene generates low-cost, persistent funding

3

Athene has compelling organic growth capabilities

4

Athene is conservatively capitalized and has a long history of minimal credit losses

5

Athene is well-managed and prepared for future dislocation

INVESTOR
DAY 2021

Client & Product Solutions

STEPHANIE DRESCHER

Chief Client & Product Development Officer



Our Differentiated Distribution Machine

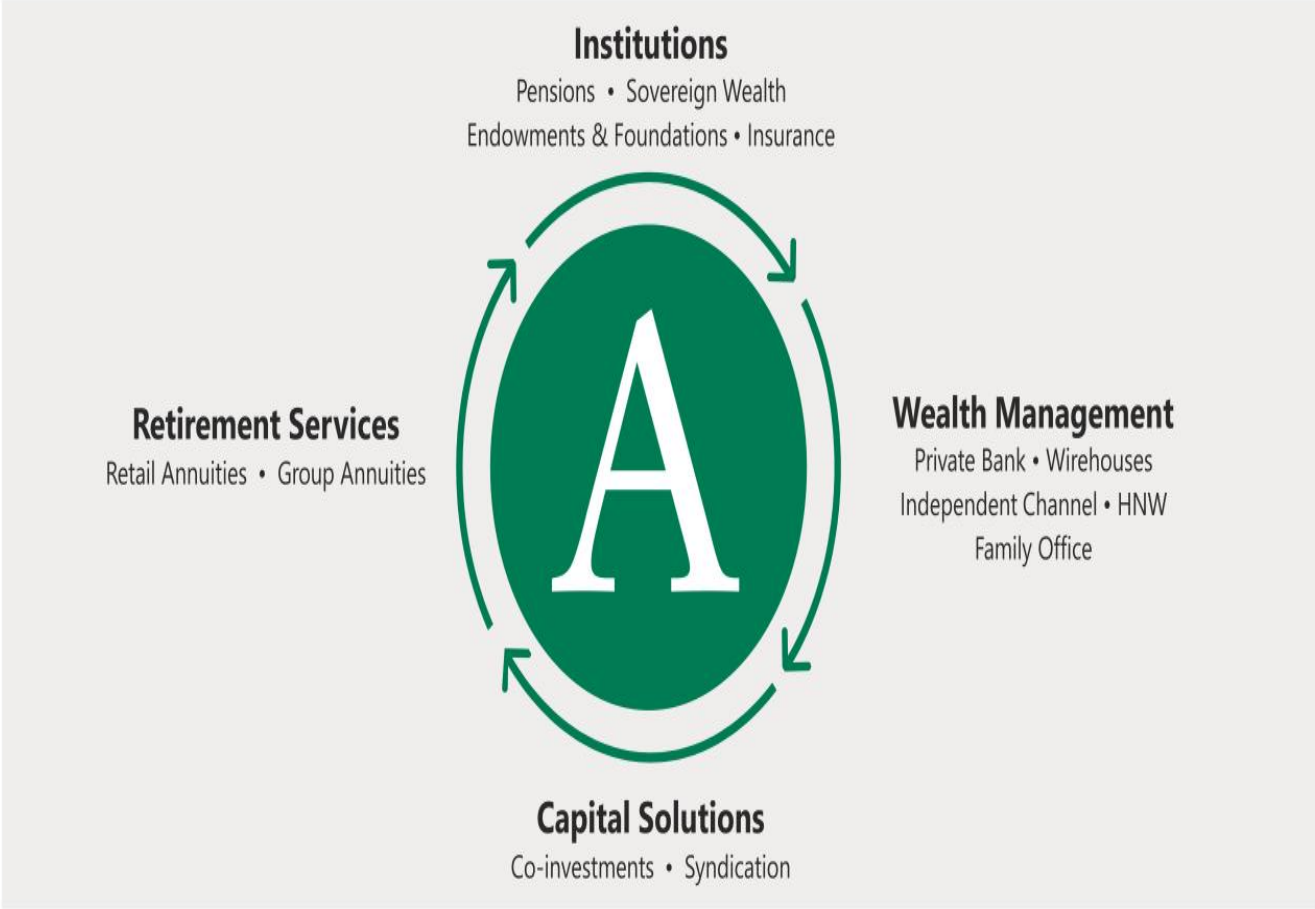

Strength of Our Franchise Serving Investors

1,426
Limited Partners

9
Average Years We've Partnered with Our LPs

138
LPs Have Been Invested with Us for 20+ Years

195
New LPs Since 2020

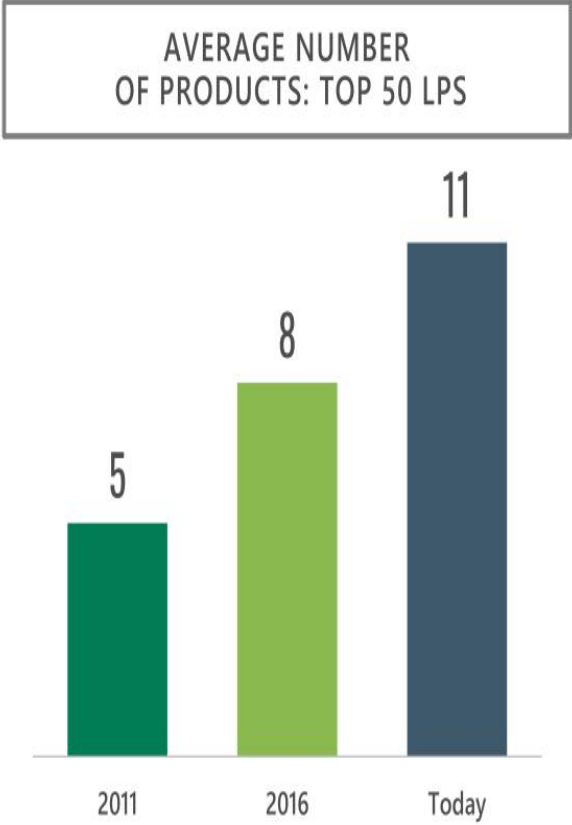

Note: All figures as of September 30, 2021 unless otherwise specified.
APOLLO INVESTOR DAY 2021

Partnering With Investors Across Risk-Reward Spectrum

Yield

- Retirement Services Platforms
- Institutions Seeking Spread
- Wealth Management Clients

ADDITIVE TO EVERYTHING WE DO

Hybrid

- Institutional Investors
- Wealth Management Clients

Equity

- Institutional Investors
- Wealth Management Clients

FUNDED IN DIFFERENT PROPORTIONS BY DIFFERENT INVESTORS

3-8%
TARGETED RETURN

9-14%
TARGETED RETURN

15-20%
TARGETED RETURN

Note: Targeted Return is indicative of gross return. Target returns are neither guarantees nor predictions or projections of future performance. Please refer to the legal disclaimer page for important performance information, including information on target returns.
APOLLO INVESTOR DAY 2021

Quietly Building Third-Party Investor Base in Our Biggest Business

GROWTH OF THIRD-PARTY AUM IN YIELD (\$B)

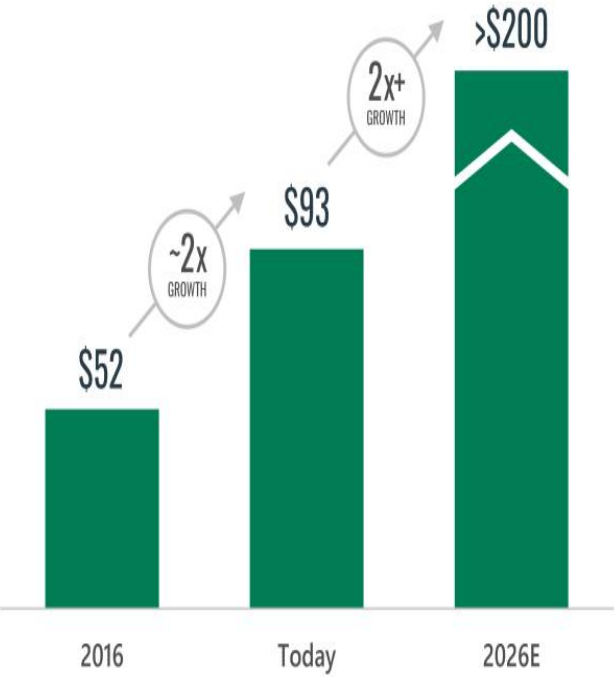

SELECTED THIRD-PARTY PRODUCTS



Redefining our Market – Major Tailwinds for Growth

INSTITUTIONAL INVESTORS

INSTITUTIONAL + HNW & MASS-AFFLUENT

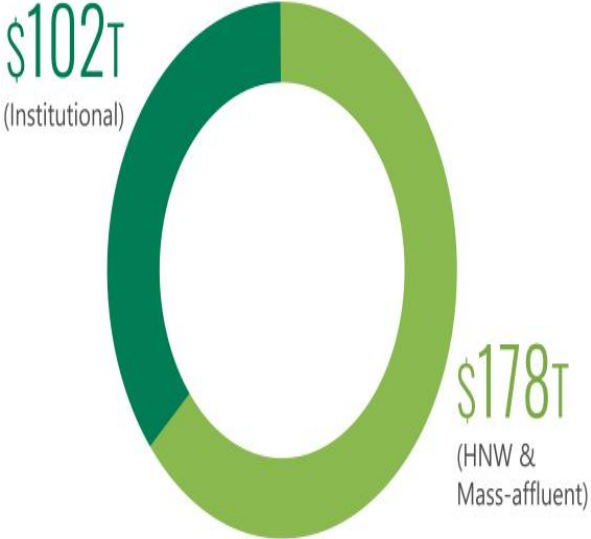
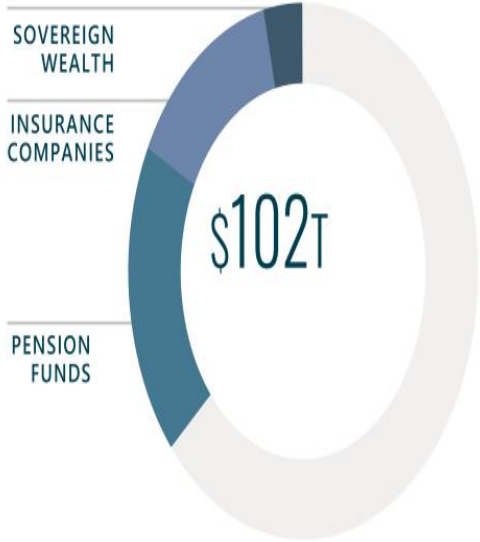

HNW and Mass-affluent are 2-5x under-allocated to alternatives
Historically, ~5% of investor base has been comprised of individual investors

Source: PWC Asset & Wealth Management Revolution: Embracing Exponential Change, McKinsey Growth Cube.
APOLLO INVESTOR DAY 2021

Excellent Fundraising Momentum Heading Into 2022

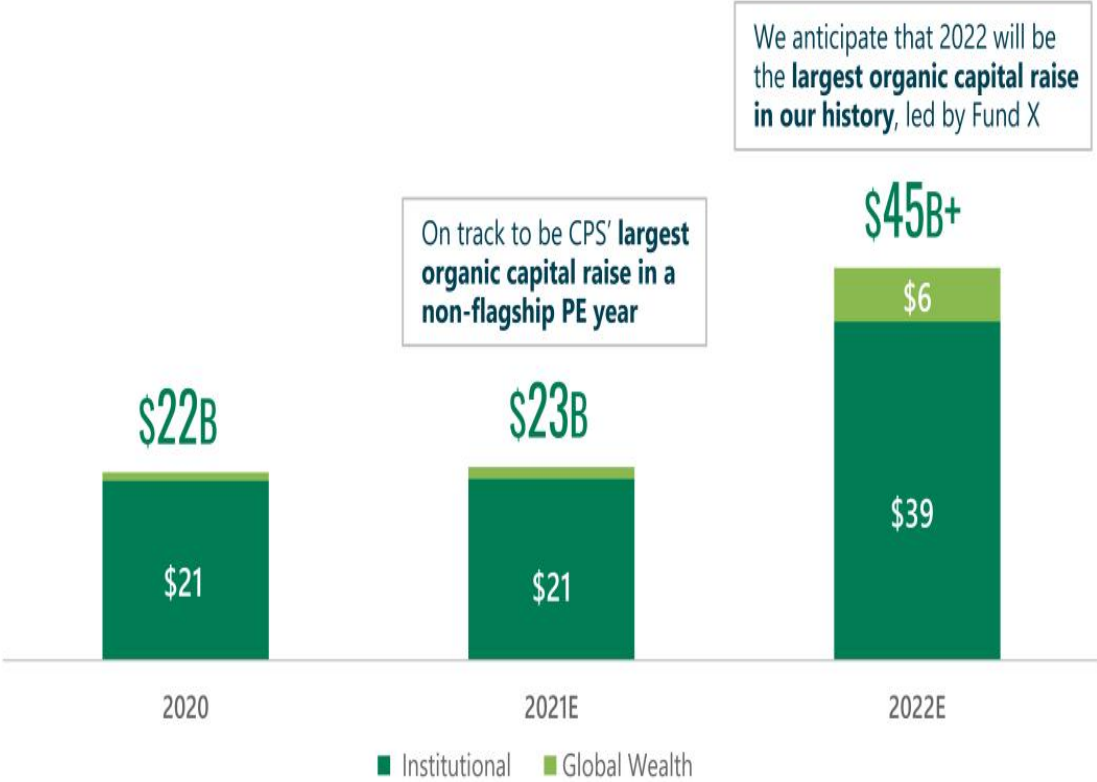

Anticipate raising a record amount of third-party organic capital for a non-flagship PE period

Our Existing Institutional Business Requires Only Modest Assumptions Over Next 5 Years

TARGETING \$5B+ OF INCREMENTAL ORGANIC INSTITUTIONAL CAPITAL RAISE PER ANNUM¹

TARGETED INSTITUTIONAL ORGANIC CAPITAL RAISE OVER NEXT 5 YEARS



1. Assumes non-PE Flagship period. Capital raise anticipated to be materially higher during periods of PE Flagship fundraise. 2. Targets may not be achieved.

Scaling Global Wealth is Our Key Bet to Turbocharging Organic Capital Raise Growth

\$14B of incremental organic capital raise per-annum by 2026

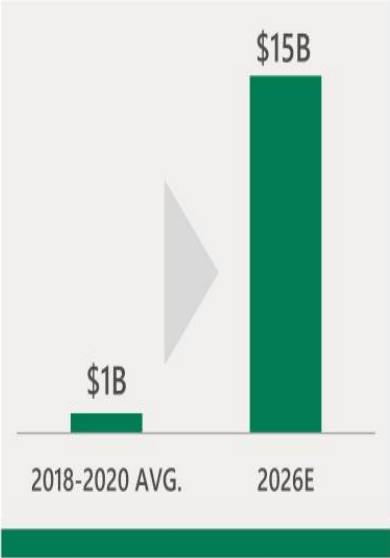

Global wealth organic capital raise over next 5 years



Global wealth expected to be meaningful portion of organic capital raise

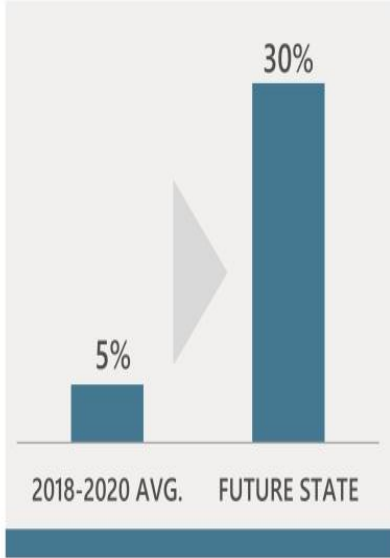

WE ARE PARTICULARLY WELL POSITIONED TO SUCCEED

1. Targets may not be achieved.
APOLLO INVESTOR DAY 2021

An Accelerated Global Wealth Build

COMMITMENT TO GROWTH

GLOBAL WEALTH HEADCOUNT

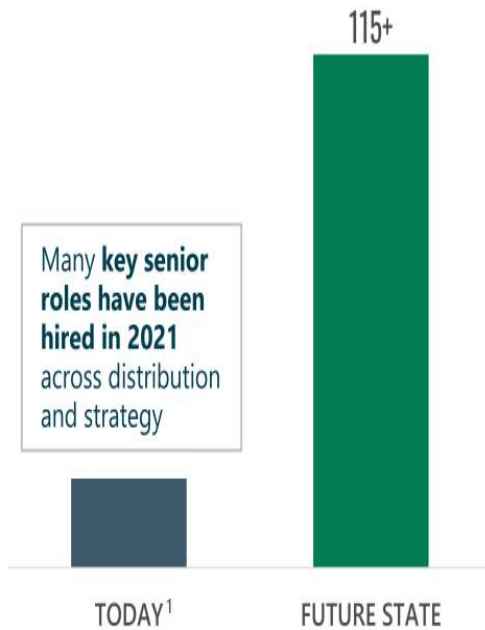

DEDICATED RESOURCES

GLOBAL DISTRIBUTION

Private Banks/Wires

Asia

U.S. Independent Channel

Europe

STRATEGY

Product Development

Technology

Marketing & Branding

Client Service & Operations

¹ As of September 30, 2021.

Strong Receptivity for Our Products

QUALIFIED PURCHASER PRODUCTS

SPAC FUND

~\$200M raised in 2-weeks with large bank platform

HYBRID VALUE FUND II

Launched with bank platform

FLAGSHIP PE FUND X

Expected to launch with multiple bank platforms and independent channel partners

MASS AFFLUENT PRODUCTS

APOLLO DEBT SOLUTIONS BDC¹

Expected to launch with a large global bank platform in Q4

Expected to launch with multiple banks and independent channel partners in Q2 2022

Banks and independent channels are increasingly interested in partnering with us

1. Non-traded BDC.

Investing Aggressively For Future Growth

KEY FOCUS AREAS

Global Hiring Across:

- SALES
- PRODUCT
- PRODUCT DEVELOPMENT
- MARKETING AND BRANDING
- EDUCATIONAL PLATFORM
- TECHNOLOGY
- CLIENT SERVICE AND OPERATIONS

CLIENT & PRODUCT SOLUTIONS HEADCOUNT

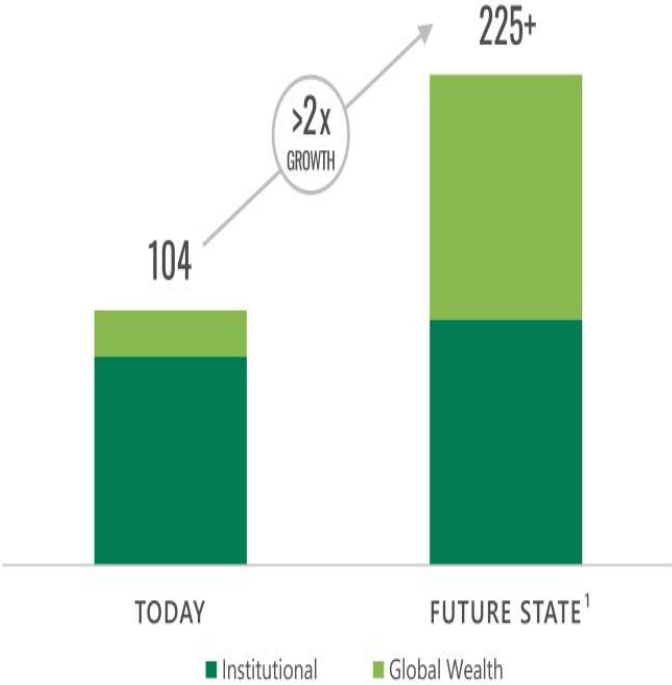

1. Target represented in "Future State" may not be achieved.

Robust Product Offering With Continued Commitment to Innovation as the LP Landscape Continues to Evolve

Search for Yield <ul style="list-style-type: none">✓ Total Return Investment Grade✓ High-Grade Alpha	Impact Investing <ul style="list-style-type: none">✓ Impact Fund I	Democratization of Finance <ul style="list-style-type: none">✓ Apollo Debt Solutions BDC^{1,2} <u>Future Pipeline</u>✓ Insurance-wrapped solutions✓ Credit and RE registered products
Large-Scale Origination <ul style="list-style-type: none">✓ Apollo Origination Partnership	Liquidity <ul style="list-style-type: none">✓ Credit Secondaries✓ GP Solutions	Market Dislocation <ul style="list-style-type: none">✓ SPAC Fund✓ Accord V¹

1. Future expected fundraises. 2. Non-traded BDC.

Key Takeaways for Client & Product Solutions

1

Strength of our franchise: brand, relationships, performance and breadth of product

2

Massive addressable market with the addition of global wealth channel

3

Investment in people and infrastructure to support the next leg of growth

4

An achievable 5-year growth plan with meaningful upside potential

The Future of Distribution

CORE PART OF HOW APOLLO IS THINKING ABOUT DISTRIBUTION

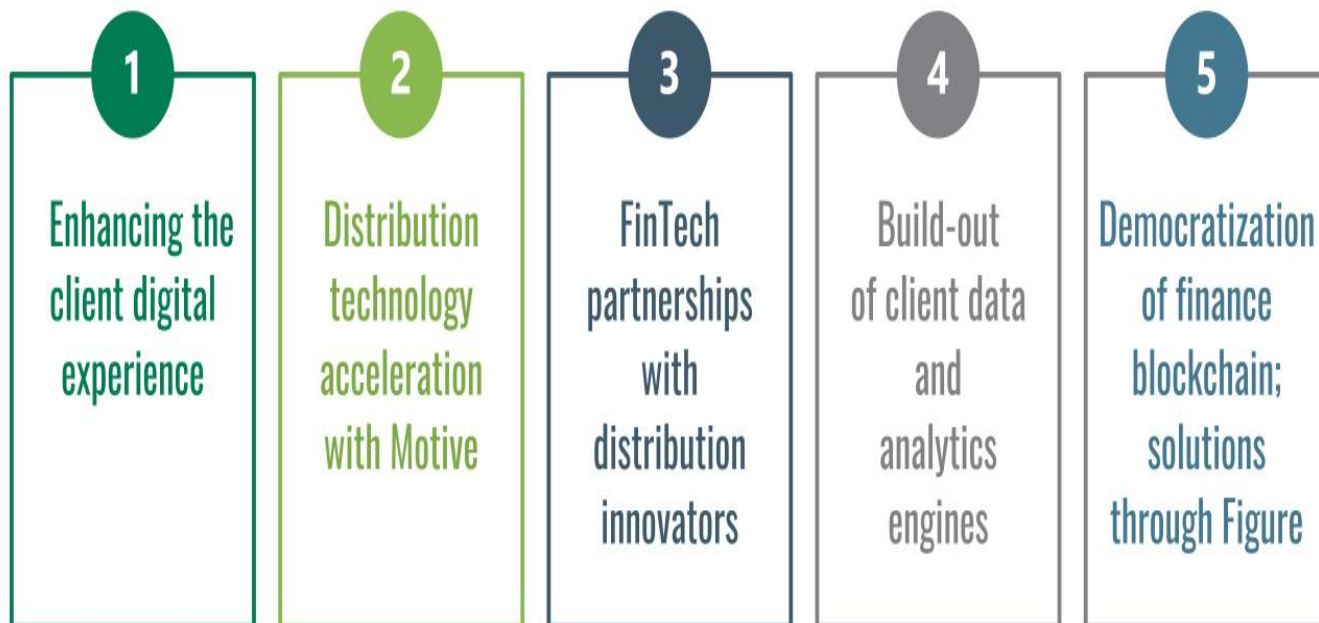

INVESTOR
DAY 2021

FinTech

BLYTHE MASTERS

Founding Partner, Motive Partners



Financial Technology Growth Potential

~12,000

FinTechs

2018

>26,000

Number of
FinTech Companies
Globally

2021

Source: Statista.com

APOLLO INVESTOR DAY 2021

187

A ~\$10 Trillion Market Opportunity by 2030

FINANCIAL TECHNOLOGY WILL CONTINUE TO TRANSFORM FINANCIAL SERVICES AND EMBED INTO NEW INDUSTRIES, EXPANDING THE VALUE OF THE MARKET SIGNIFICANTLY BY 2030

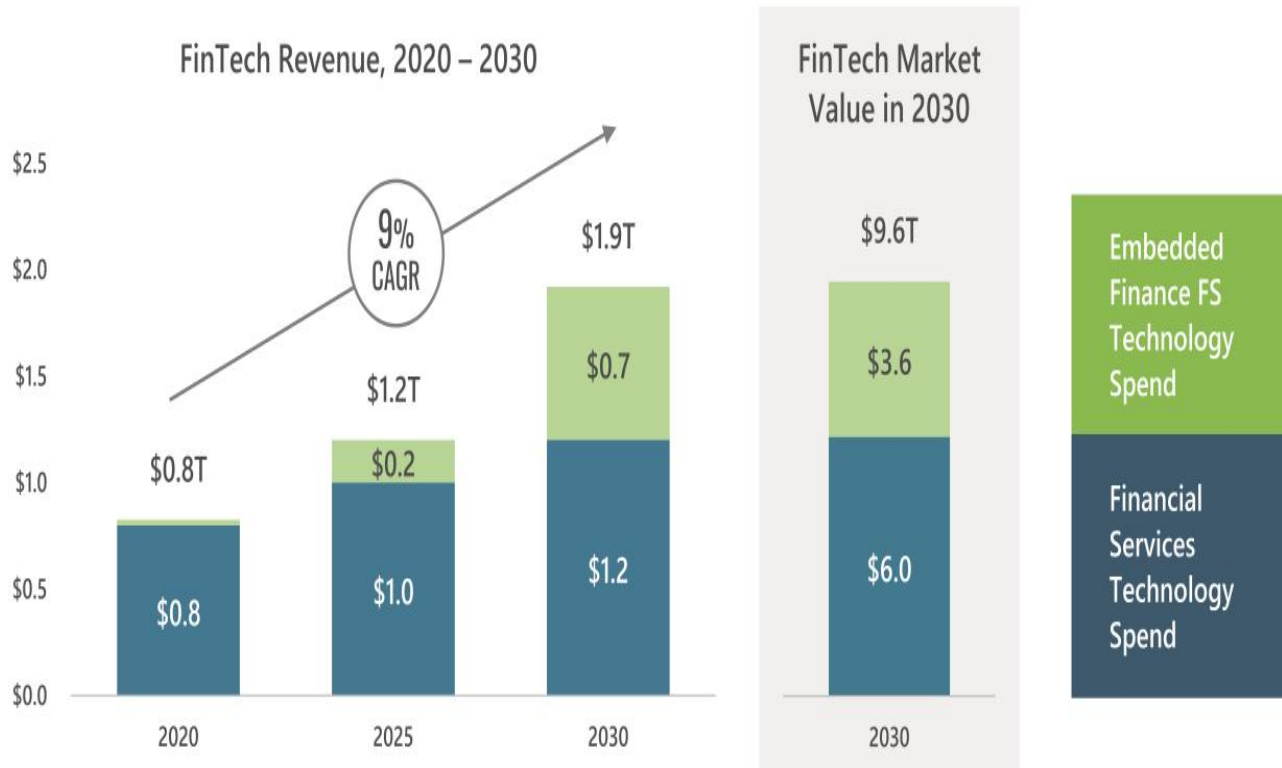

Method: Financial Services Technology spend represents total IT spend by Financial Services Institutions in Banking, Securities (Capital Markets & Investment Management) and Insurance. 2020 spend calculated by Gartner. 2025 and 2030 calculated through application of average CAGR (2017-2022): Banking (4.3%), Securities (3.9%) and Insurance (3.5%). Embedded Finance FS spend represents the revenue opportunity for FS technology across non-FS industries. 2020 & 2025 provided by Lightyear Capital, 2030 calculated by Bain Venture Capital using Lightyear Capital inputs.

FinTech Challengers Trade at Significant Premiums to Incumbents



Source: S&P Capital IQ. Market data as of October 7, 2021. 1. Price / Earnings multiples are based on consensus normalized EPS estimates for 2022E. Robinhood, Upstart, and SoFi multiples are illustrative due to negative or very low consensus normalized EPS estimates for 2022E.

What is Motive Partners Doing with Apollo?

THE MOTIVE TEAM'S EXCEPTIONAL FINTECH EXPERTISE AND NETWORK IS EXPECTED TO SIGNIFICANTLY ENHANCE APOLLO'S EFFORTS TO EXPAND AND IMPROVE TECHNOLOGY CAPABILITIES THROUGHOUT ITS ENTIRE PLATFORM

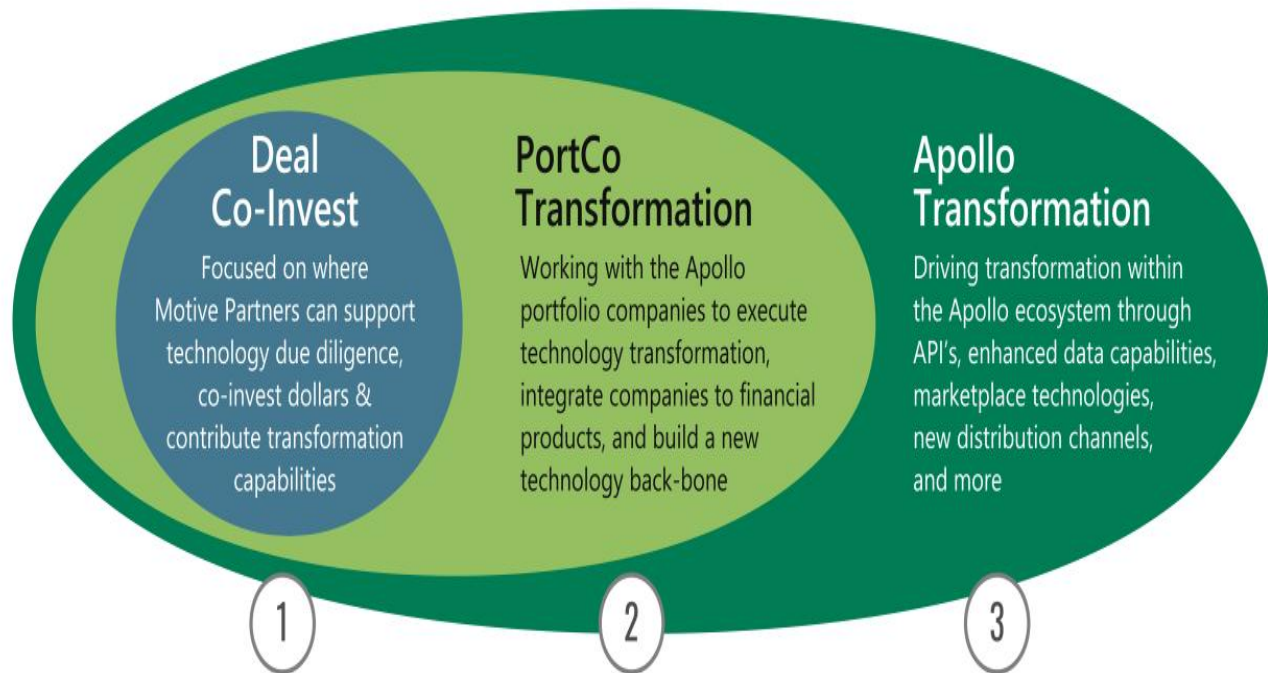

Supported by Motive's financial technology expertise in investing, operating & innovation

Apollo Has Multiple Roles to Play Within FinTech



Apollo as a **Validator**



We **validate** business models and leverage FinTech products to improve our own financial services franchise

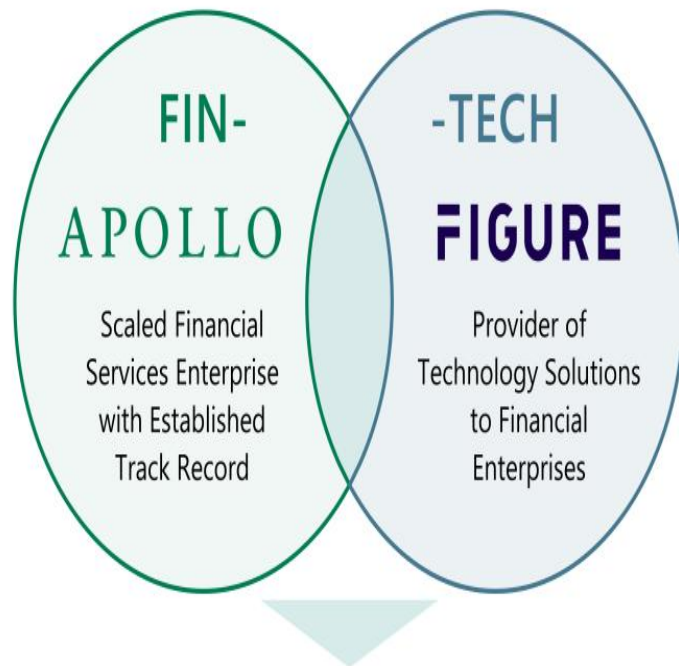

Combination of Apollo's securitization market presence and Figure's proprietary blockchain technology provides:



INCREASED SECURITY



COST SAVINGS



REAL-TIME INFORMATION

Apollo as an **Enabler**



We **enable** growth through mutually beneficial partnerships with best-in-class companies

ACCESS TO HIGH-QUALITY ORIGINATIONS,
UNDERWRITING, & SECTOR EXPERTISE



APOLLO

VICTORY PARK
CAPITAL



FLEXIBLE CAPITAL, STRUCTURING
CAPABILITIES & CORPORATE RELATIONSHIPS

Apollo lends via its low-cost balance sheet to niche tech providers, enabling outsized growth and delivering upside back to Apollo through economic alignment

Apollo as a Partner



We partner by providing a source of financing & access to broad in-place infrastructure

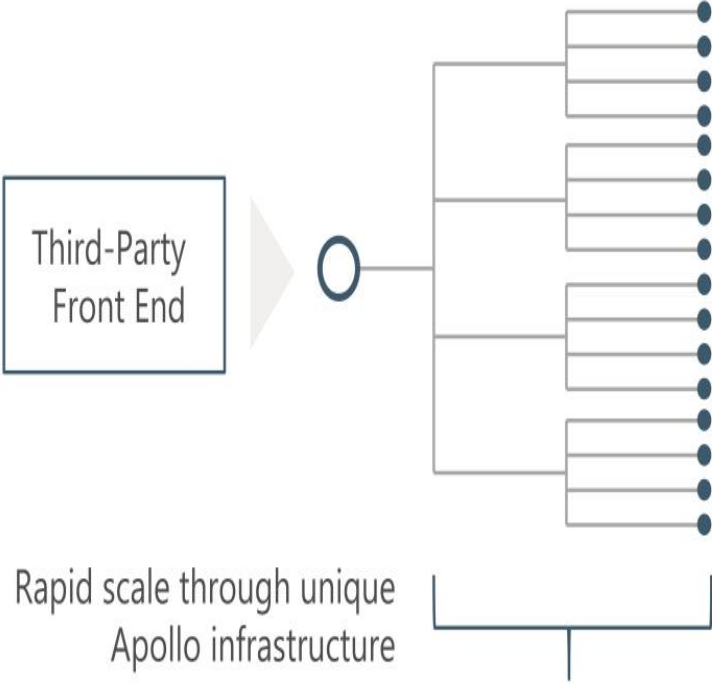

Apollo as an Investor



We **invest** directly, through our funds, and through our stake in Motive to generate strong financial outcomes

APOLLO

LEADER IN
FINANCIAL SERVICES INVESTING

OneMain
Financial

ATHENE

ATHORA

VENERABLE

AmeriHome
mortgage

ASPEN

PK AirFinance

DONLEN

27% GROSS IRR ACROSS
20+ FIG INVESTMENTS¹



MOTIVE PARTNERS

LEADER IN
TECHNOLOGY INVESTING

dun & bradstreet Forge

INSURIFY

investcloud

Wilshire

avaloq

Tegra118

FINANTIX

40% GROSS IRR /
25% NET IRR²

1. Reflects Realized Gross IRR as of March 31, 2021 on all FIG-related investments since 1993. These investments represent performance of all Apollo FIG investments through both fund investment as well as co-investment structure. Gross IRR does not reflect the effect of management fees, incentive compensation, certain expenses or taxes. 2. Reflects Gross IRR and Net IRR as of June 30, 2021.

Apollo as an **Actor**



Apollo is poised to **ACT** as a disruptor within Financial Services by combining our core attributes with emerging FinTech capabilities to unlock a new phase of growth across all segments of our business

Extensive
Financial
Infrastructure

Established
Investing Track
Record & Brand

Strategic
Balance Sheet
Capacity

FinTech
Capabilities &
Partnerships

INVESTOR
DAY 2021

Expanding Opportunity

JONATHAN SIMON

Head of Leadership Development & Diversity, Equity and Inclusion



Co-Creating New Innovations to Expand Opportunity

Workplace

Marketplace

Community

APOLLO AFFINITY NETWORKS



**INVESTOR
DAY 2021**

Expanding Opportunity

VIDEO MODULE



INVESTOR
DAY 2021

Financial Overview & Strategy

MARTIN KELLY

Chief Financial Officer & Co-Chief Operating Officer



Capturing Our Financial Opportunity

1

High Growth Alternative Asset Manager

IN OUR BASE CASE (BY 2026)

- ~2x AUM
- ~2.25x Fee Related Revenues and ~2.5x FRE
- Realization "super-cycle"

2

Substantial Earnings Power

HIGHLY ACCRETIVE MERGER

- DE increasing over 4x vs. Apollo trailing 5 year average
- Growing and durable spread related earnings (SRE)
- Full alignment driving platform growth and agility

3

Significant Capital Generation

~\$15B OF CAPITAL GENERATION

Illustratively:

- ~\$5B investment for growth
 - ~\$5B in base dividend
 - ~\$5B for additional capital return through dividends and buybacks
- ~\$10B OF FURTHER EQUITY DEPLOYMENT CAPACITY AT ATHENE

Strong Momentum Heading into 2022

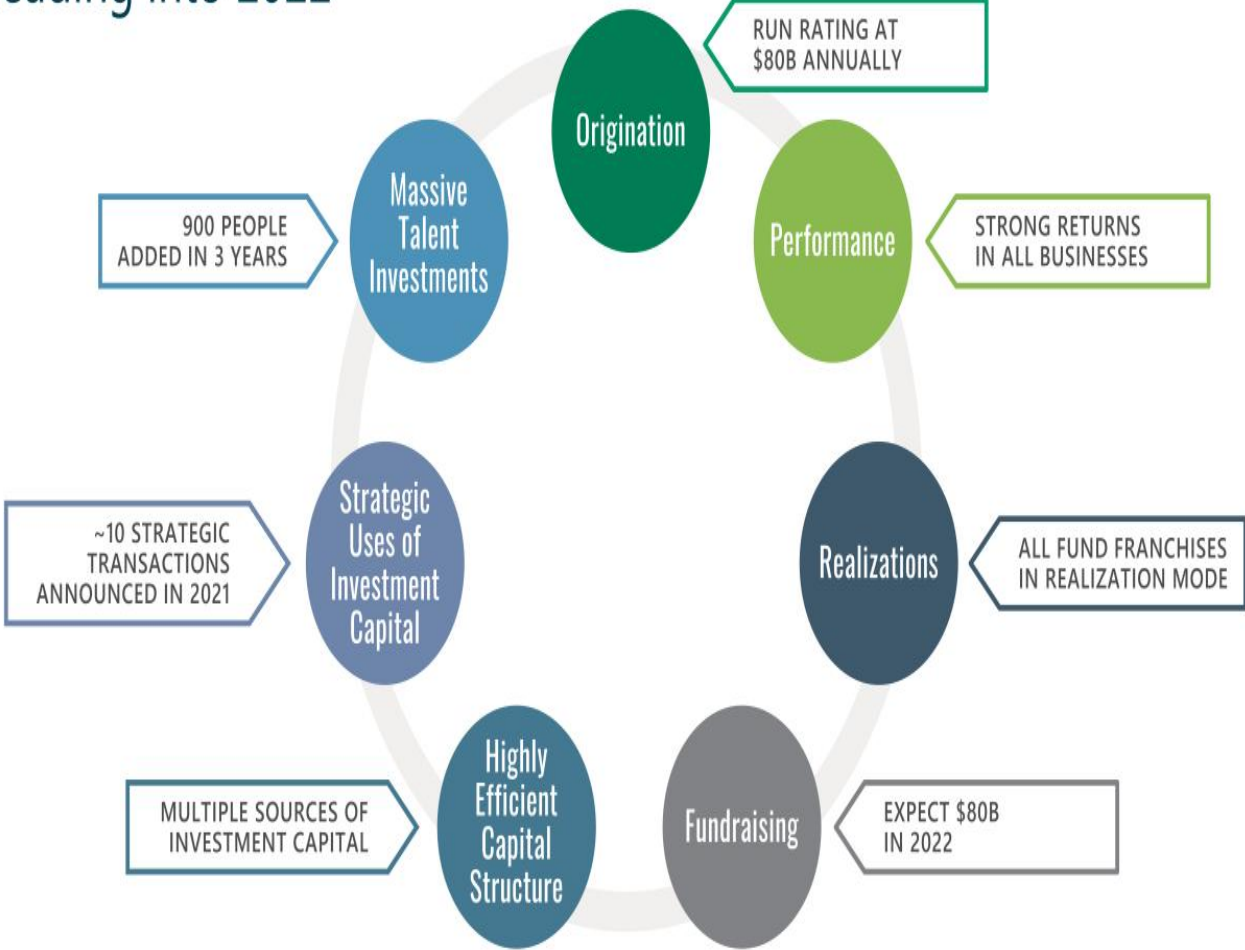

New Financial Construction With Three Pillars of Strength

DISTRIBUTABLE EARNINGS DERIVED FROM DIVERSIFIED AND GROWING EARNINGS STREAMS

ASSET MANAGEMENT

- Growing management fees backed by high concentration of permanent capital
- Capital solutions franchise driving transaction fee growth
- Highly profitable with inherent operating leverage

Fee Related Earnings
FRE

RETIREMENT SERVICES

- Income from investment grade assets (~95% of fixed income portfolio)¹
- Income from equities (~5%) including strategic platforms
- Low-cost funding and operating model

Spread Related Earnings
SRE

PRINCIPAL INVESTING

- Strategic equity investments
- Performance fees
- Corporate and certain financing activities

Principal Investing Income
PII

1. As of June 30, 2021 94% of AFS securities designated NAIC 1 or 2.

Business Segments Structured to Optimize Transparency & Returns

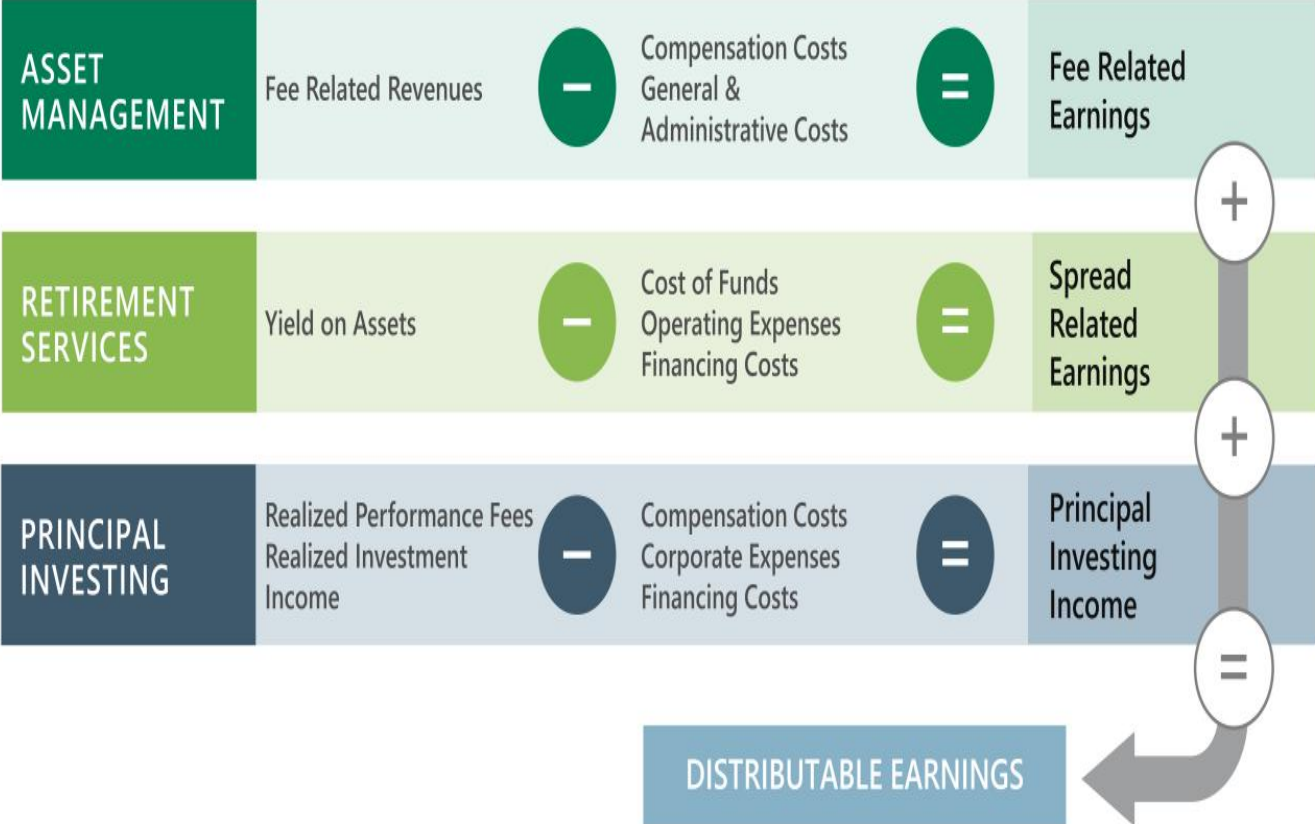

Durable and Growing Earnings Streams

~90% OF PRE-TAX EARNINGS GENERATED FROM RECURRING FRE AND SRE



(\$/SHARE, PRE-TAX)



1. Pro-forma for post merger share count of approximately 600mm shares, including anticipated equity awards related to compensation reset. 2. Reflects anticipated pro-forma allocation of expenses across segments. 3. Normalized. Please see appendix for more detail. 4. Includes estimated purchase accounting benefits.

Attractive Growth with Significant Upside Potential

DISTRIBUTABLE EARNINGS GROWING TO >\$9/SHARE BEFORE INVESTMENT FOR GROWTH & EMBEDDED OPTIONS

FRE + SRE + PRINCIPAL INVESTING

EARNINGS ON INVESTMENT

(\$/SHARE, AFTER-TAX)



1. Represents Apollo standalone historical results. 2. Pro-forma for post merger share count of approximately 600mm shares, including anticipated equity awards related to compensation reset, and assumed post merger tax rate of 18%.

Positioning Apollo for the Future

MERGER WITH ATHENE CLEARS THE PATH FOR RATIONALIZATION AND CLEAR GROWTH AHEAD

- Balance sheet re-organization – transfer of Apollo investment portfolio to Athene¹
- Consolidation of investments in operating platforms¹
- Investment capital:
 - Group cash earnings
 - Utilization of Athene equity portfolio capacity
- Aligning and future proofing our business
- Massive reset of our compensation structure

- Full organizational alignment
- Growth acceleration
- Resetting our FRE comp trajectory
- More efficient capital usage

1. Transfers do not represent 100% of Apollo investment portfolio or operating platforms.

Reset of Compensation Structure Aligned with Shareholders

- Greater portion of compensation for investment professionals aligned with performance
- Legacy profit share program for broad employee base replaced with APO shares
- Long-term award of APO shares to partners
- Results in lower FRE compensation expense trajectory going forward

	TODAY	BY 2026
FRE Comp Ratio	30%	~25%
PII Comp Ratio	50% ¹	60-70% ²

Note: Comp Ratio defined as Compensation Expense divided by Revenues. 1. Reflects average of 2020 actual and 2021 expected compensation ratios. 2. Indicative based on average expected revenues from 2022E through 2026E.

Components of FRE Growth – Base Case

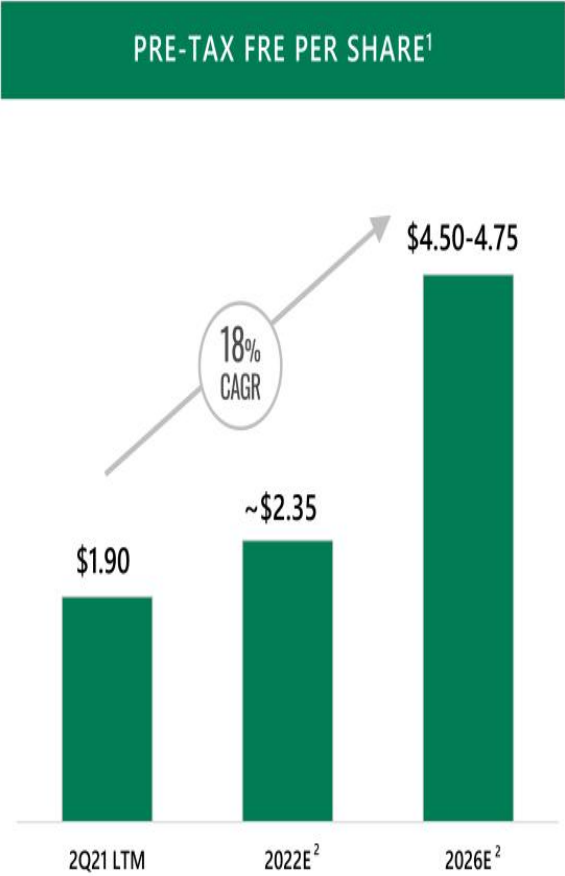

1. Pro-forma for post merger share count of approximately 600mm shares, including anticipated equity awards related to compensation reset. 2. Reflects anticipated pro-forma allocation of expenses across segments.

Multiple Levers Available to Achieve AUM Targets

DIVERSIFIED PATHS TO ACHIEVING AUM TARGET

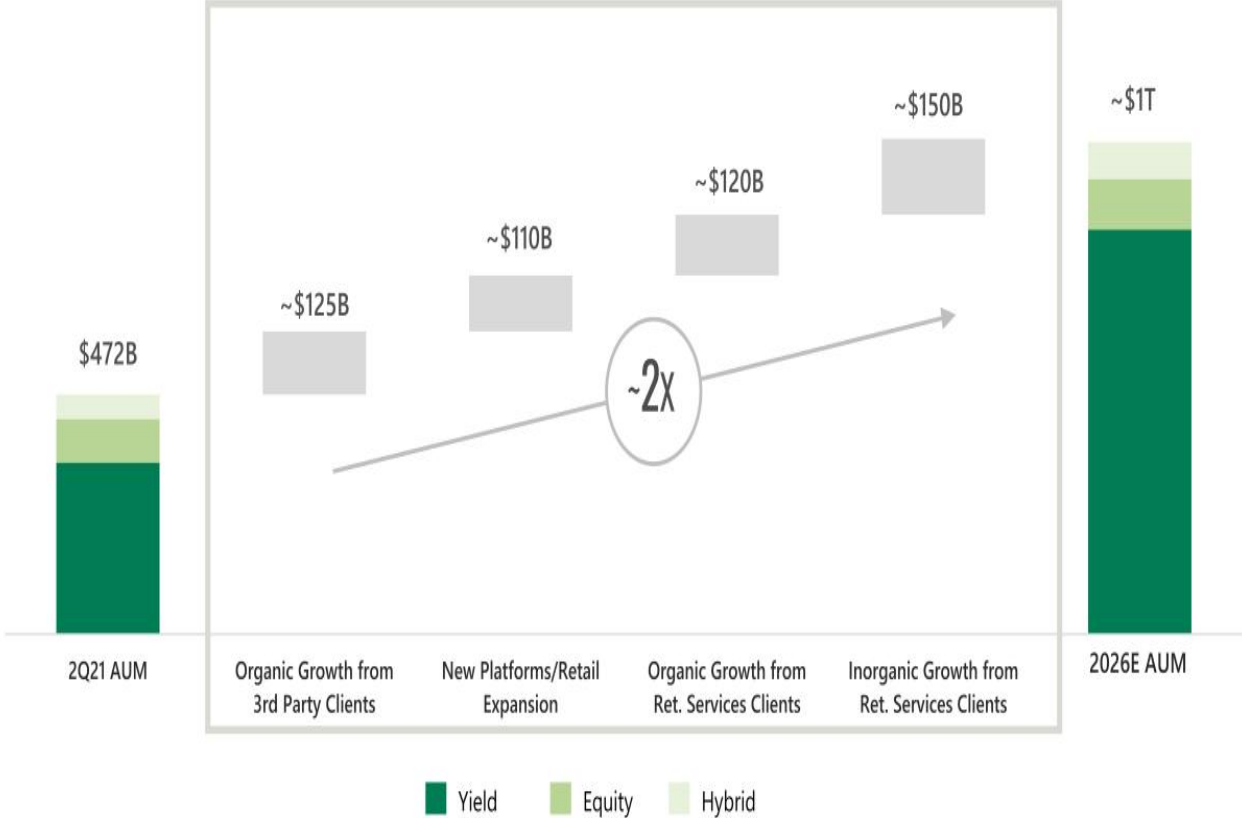

Massive Investments in Talent Will Enable Next Leg of Growth

HEADCOUNT INVESTMENT (2019-2021 YTD)

Investment Teams **265**

- Hybrid Value
- Infrastructure
- Credit

Distribution **40**

- Retail/Global Wealth
- Geographic Expansion
- Broader Coverage

Enterprise Solutions **595**

- Operations
- Technology
- Enterprise Risk Mgmt.

US **295**

International **300**

1/3rd of new hires in lower cost locations

Total **900**

NEARING COMPLETION OF CURRENT INVESTMENT CYCLE

OPERATING LEVERAGE ACCELERATED INVESTMENT PERIOD OPERATING LEVERAGE

(HEADCOUNT GROWTH)

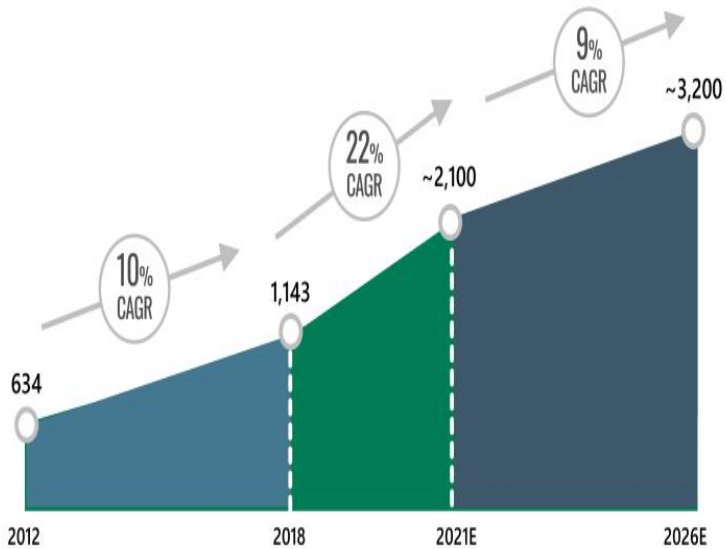

Next-Gen Workplace & Technology Investments Drive Efficiency

TECHNOLOGY / REAL ESTATE INVESTMENTS

(\$M)

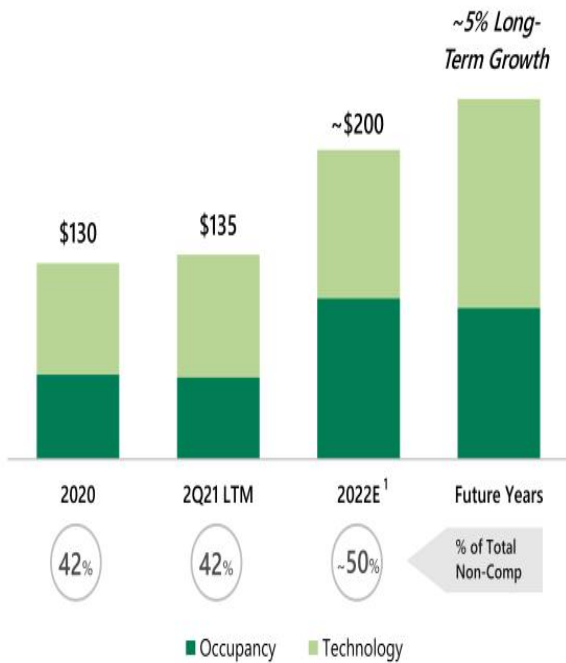

NEARING COMPLETION OF CURRENT INVESTMENT CYCLE

- Global reset of all our workplace environments
- Office investments in all major centers to support growth priorities and talent location strategy
- Expect non-compensation expenses to fully re-base by 2022
- Developing scalable technology in conjunction with Motive and Figure

1. Reflects anticipated pro-forma allocation of expenses across segments.

Today's Investments Will Drive Additional Margin Expansion

WE MANAGE OUR ASSET MANAGER WITH A PRIMARY LENS ON FRE DOLLAR GROWTH

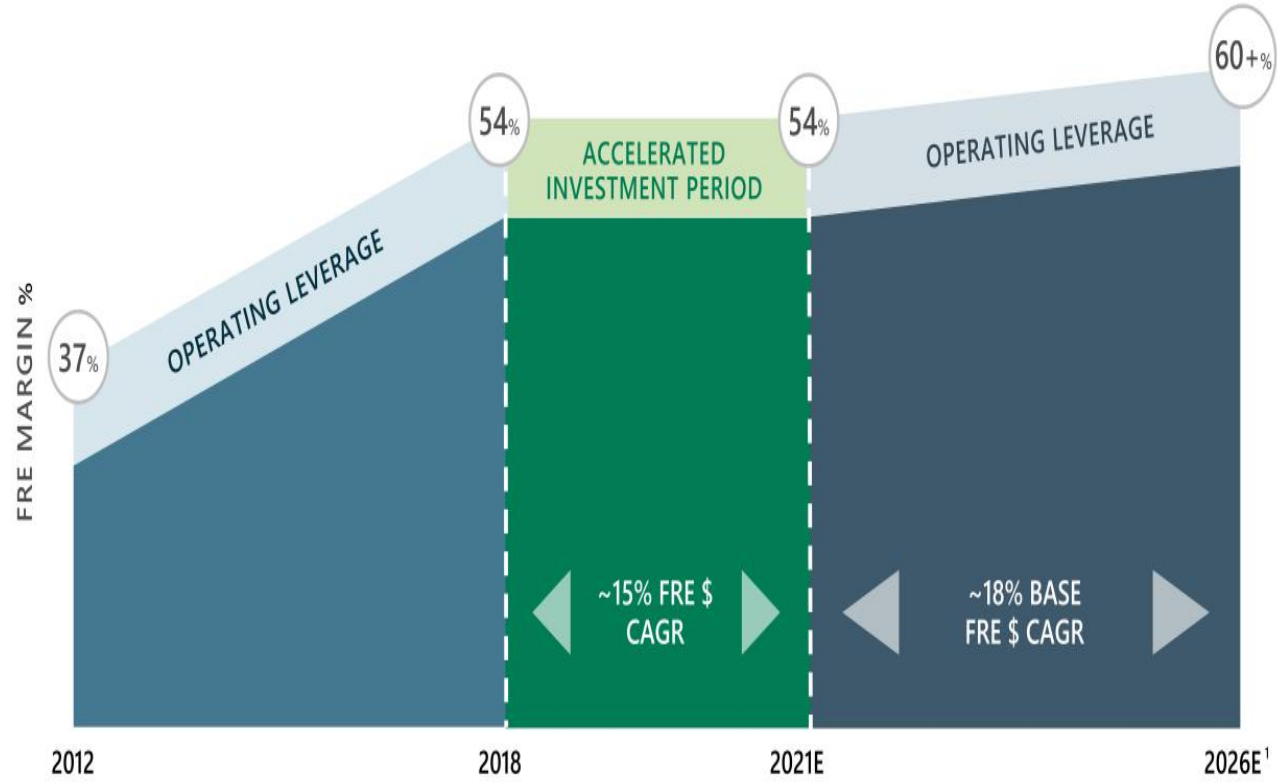

1. Reflects anticipated pro-forma allocation of expenses across segments.
APOLLO INVESTOR DAY 2021

Components of Spread Related Earnings – Base Case

Net Invested Assets = ~1.5x Growth

Yield on Net Invested Assets
Cost of Funds = 1.40-1.50% Net Inv Spread

Fees on ADIP Assets (~5x growth)¹

Operating Expenses
& Financing Costs = ~0.35%

SRE = Low Double Digit CAGR

PRE-TAX SRE PER SHARE ²

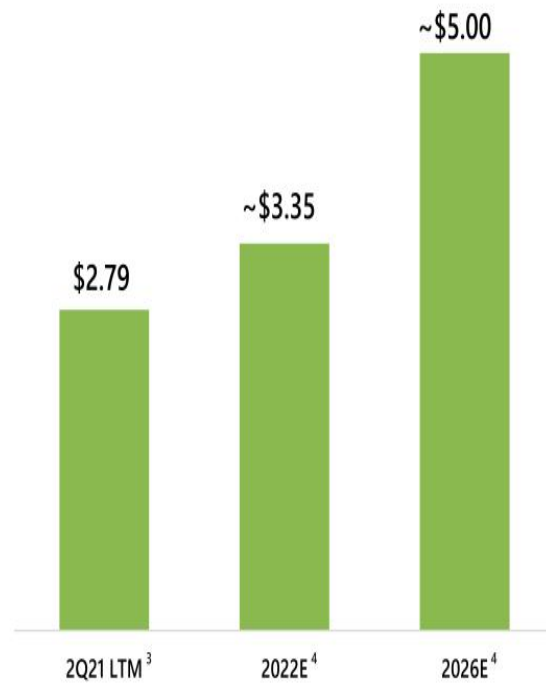

1. Athene earns ~15bps on all liabilities ADIP supports. Estimated multiplier versus fees earned in last twelve months ended June 30, 2021. 2. Pro-forma for post merger share count of approximately 600mm shares, including anticipated equity awards related to compensation reset. 3. Normalized. Please see appendix for more detail. 4. Includes estimated purchase accounting benefits.

Growing Assets and Earnings with Efficient Capital Deployment

A THIRD OF ASSETS EXPECTED TO BE SUPPORTED BY CAPITAL EFFICIENT ADIP STRUCTURE BY 2026E

GROSS INVESTED ASSETS

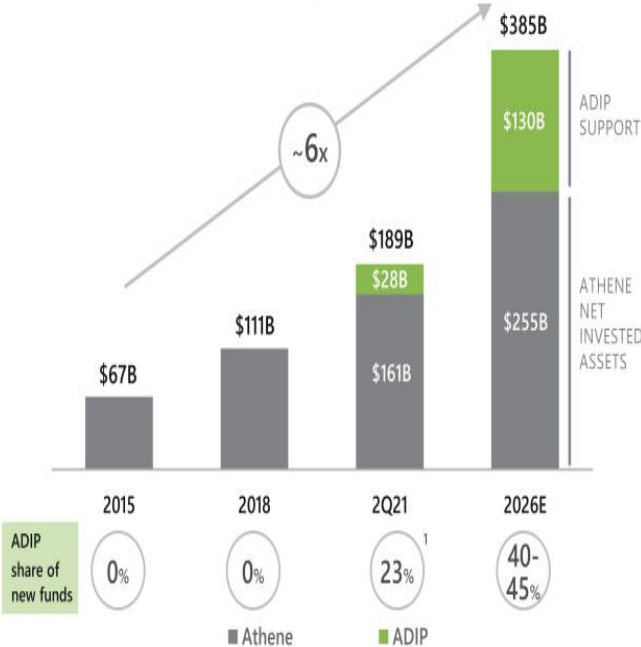

STABLE RECURRING SPREAD²

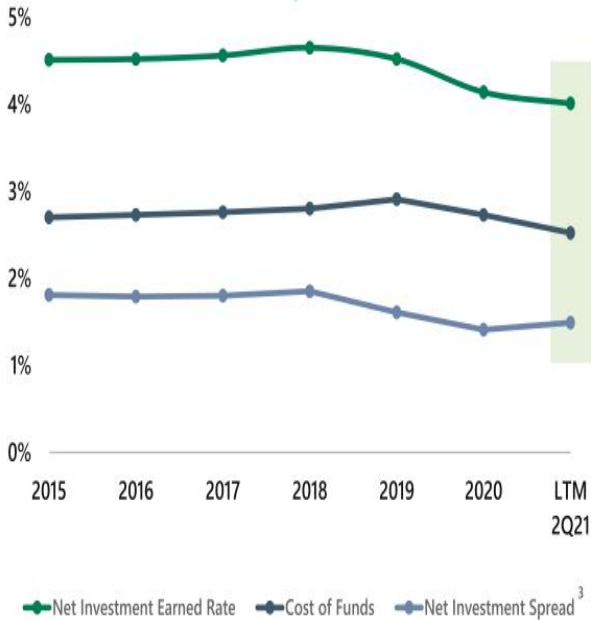

1. Cumulative flows since inception through 2Q21. 2. Normalized for 11% alts performance and notable items. 3. Before consideration of operating expenses and financing costs (interest and preferred dividends).

Components of Principal Investing Income – Base Case

CONSISTENTLY PROFITABLE UNIT HOUSING GROWTH CAPITAL, STRATEGIC INVESTMENTS & PERFORMANCE FEE INCOME

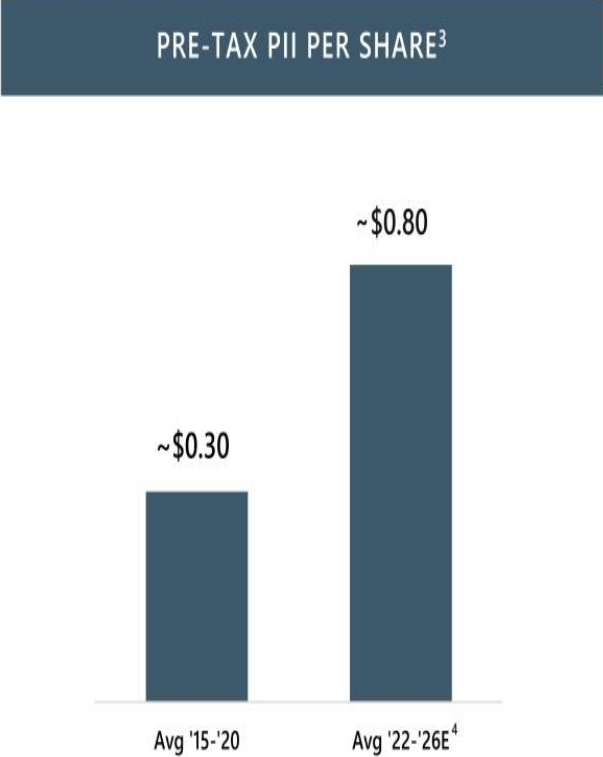

1. Reflects average of 2020 actual and 2021 expected compensation ratios. 2. Indicative based on average expected revenues from 2022E through 2026E. 3. Pro-forma for post merger share count of approximately 600mm shares, including anticipated equity awards related to compensation reset. 4. Reflects anticipated pro-forma allocation of expenses across segments.

Strong Performance Supports Realization Activity

>70% OF EXPECTED GROSS PERFORMANCE FEES FROM ESTABLISHED FUNDS WITH STRONG TRACK RECORD

PRIMARY PERFORMANCE FEE DRIVERS

FUND	SIZE	GROSS ²	
	(\$B)	RETURN	MOIC
Fund IX	\$25	49%	1.5x
Fund VIII	\$18	19%	1.9x
Credit Strategies	\$4	12% ³	n/a
EPF III	\$4	20%	1.3x
HVF I	\$3	29%	1.3x

NET PERFORMANCE FEE RECEIVABLE¹

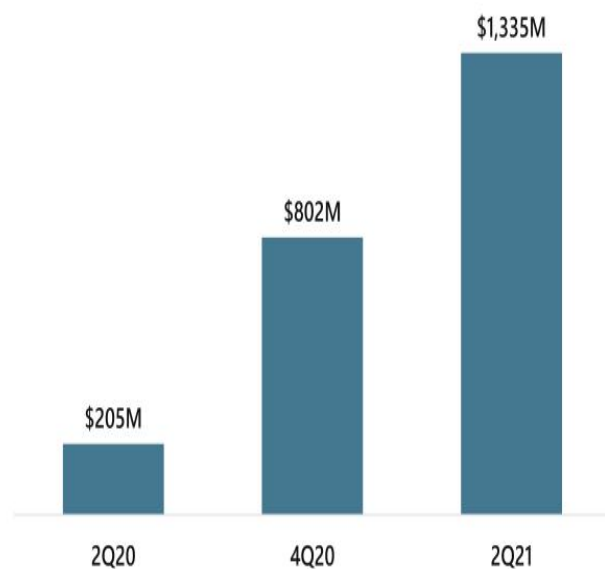

1. Net performance receivable represents the sum of performance allocations and incentive fee receivable, less profit sharing payable as reported on the consolidated statements of financial condition, and includes certain eliminations related to investments in consolidated funds and VIEs and other adjustments.
 2. Actual results through June 30, 2021. 3. Quoted as gross annualized ROE.

Bringing the Earnings Components Together

STRONG GROWTH PROFILE WITH VAST MAJORITY DRIVEN BY RECURRING EARNING STREAMS

(\$B, EXCEPT PER SHARE AMOUNTS)

	2022E	2026E
Fee Related Earnings	\$1.4	\$2.8
Spread Related Earnings	\$2.0	\$3.0
FRE + SRE¹	\$3.4	\$5.8
Principal Investing Income ¹	\$0.5	\$1.0
Pre-Tax Distributable Earnings	\$4.0	\$6.8
Tax ²	(\$0.7)	(\$1.3)
Distributable Earnings	\$3.3	\$5.5
<i>Per Share³</i>	~\$5.50	>\$9

18%
CAGR

Before ~\$5B
investment
for growth

1. Reflects anticipated pro-forma allocation of expenses across segments in FRE and Principal Investing. Includes estimated purchase accounting benefits in SRE. 2. Assumed post merger tax rate of 18%. 3. Pro-forma for post merger share count of approximately 600mm shares, including anticipated equity awards related to compensation reset.

Capital Generation

SIGNIFICANT INVESTMENT AND CAPITAL RETURN CAPACITY WITHIN TARGET RATINGS

(\$B)	2022-2026E
Starting cash to invest	\$1.5
Free cash flow from FRE & Principal Investing (less corp cash needs)	9.5
Cumulative expected distribution of excess capital from Athene	3.8
Aggregate capital to invest before dividends	\$14.8
<i>Less: Cumulative dividends at current \$1.60/share</i>	<i>(4.8)</i>
Available for investment and additional return to shareholders	\$10.0

Accelerated, Capital Efficient Growth Paradigm

EXAMPLES OF INVESTMENTS YTD '21

CAPITAL PROVIDER

	EXAMPLES OF INVESTMENTS YTD '21	CAPITAL PROVIDER
Strategic Assets	FIGURE	Principal Investing (HoldCo)
	 MOTIVE PARTNERS	
Asia Expansion	challenger 	PI (HoldCo) /  ATHENE
	FWD	 ATHENE
Origination Platforms	 Foundation Home Loans	 ATHENE
	MaxCap Group	 ATHORA
	VICTORY PARK CAPITAL	 ATHENE
	newfi	 ATHENE

Note: Certain of the investments presented above are minority investments.
 APOLLO INVESTOR DAY 2021

Significant Upside Given APO's Target Growth Profile

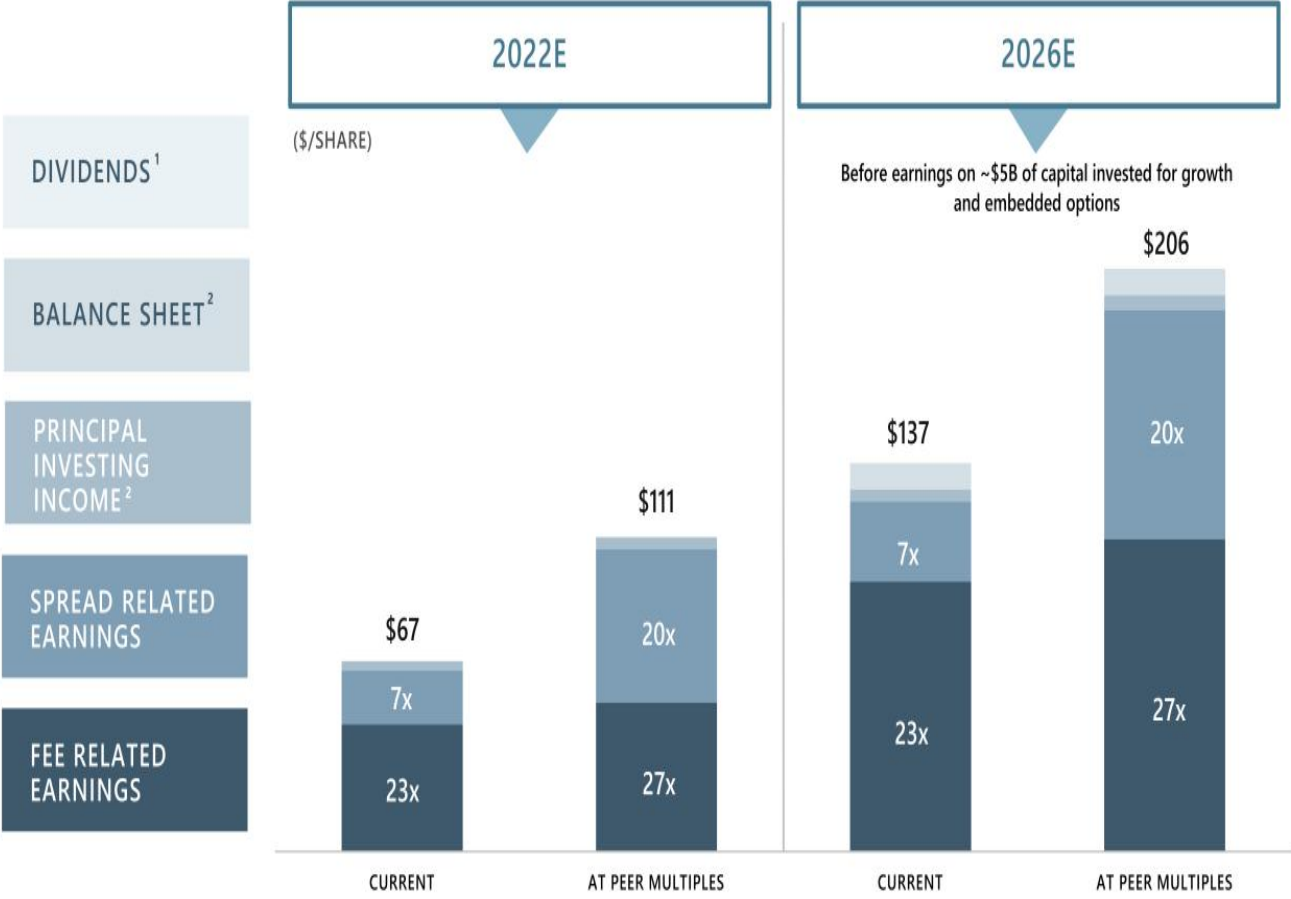

1. Cumulative at current expected 2022E dividend of \$1.60/share. 2. In Current: Principal Investing Income valued at 4x earnings multiple and Balance Sheet at 1x book value multiple. At Peer Multiples: FRE multiple based on select sell-side analyst models for Ares, Blackstone, Carlyle and KKR. SRE multiple established at a discount to FRE multiples applied to similar peer earnings streams. Principal Investing Income valued at 5x earnings and Balance Sheet at 1x book value multiple.

Five Key Takeaways

- 1 High growth base plan** over next 5 years
~2x AUM
~2.25x Fee Revenue + earnings on ~\$5 billion of growth capital¹
~2.5x FRE
- 2 Largest addressable market** among alternatives peers
Unique ecosystem built for massive credit opportunity
- 3 Athene is a competitive differentiator** and **growth accelerant**
Merger has many strategic benefits and allows us to capture large amounts of undervalued spread earnings
- 4 Our model is highly capital efficient**
\$15 billion of capital generation over next 5 years to accelerate growth and return to shareholders
- 5 Strong momentum** behind aligned team
Industry's best talent, aligned with changes to compensation philosophy

¹ Pro-forma for announced merger with Athene.

**INVESTOR
DAY 2021**

Closing and Q&A

**MARC ROWAN, JIM ZELTER, SCOTT KLEINMAN,
AND MARTIN KELLY**



INVESTOR
DAY 2021

Appendix & Supplements



Asset Management Business Components

BUSINESS REPORTING COMPONENTS ORIENTED AROUND INVESTING STRATEGIES

	AUM / FGAUM	MANAGEMENT FEES	FEE RELATED REVENUES	FEE RELATED EXPENSES	FEE RELATED EARNINGS
Yield	X	X			
Hybrid	X	X			
Equity	X	X			
Asset Management	X	X	X	X	X

Asset Management Reporting Changes

CHANGE IN REPORTING BETTER REFLECTS ASSET MANAGEMENT INVESTMENT STRATEGIES

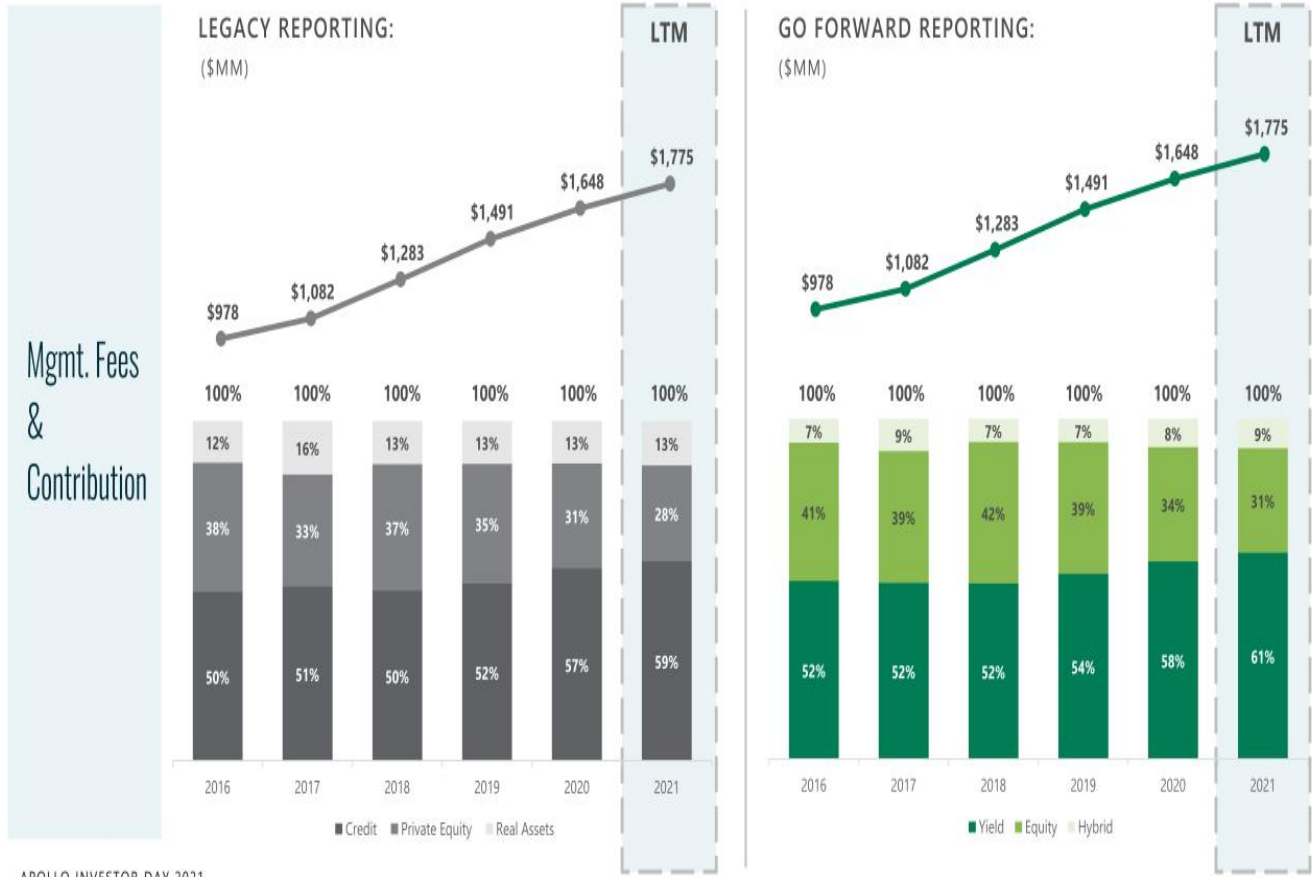

Asset Management Reporting Changes

CHANGE IN REPORTING BETTER REFLECTS ASSET MANAGEMENT INVESTMENT STRATEGIES



Attractive Pro-Forma Balance Sheet

PLAN TO CONTINUE TO OPERATE AS TWO DISTINCT CREDIT GROUPS

HoldCo / Asset Manager Apollo Stand-Alone Balance Sheet Highlights

\$1.8B
cash & cash equivalents

11.4 years
average debt maturity

3.5%
after-tax cost of debt¹

Fitch A / Stable

S&P A- / Positive

\$3.2B
total debt

Retirement Services Stand-Alone Balance Sheet Highlights²

\$6.8B
excess capital and
debt capacity³

13.5%
adjusted debt
to capital ratio

S&P A+ / Stable

AM Best A / Stable

Fitch A / Positive

Pro-forma post merger share count currently estimated at approximately 600 million shares

Note: Data as of June 30, 2021. 1. At assumed 18% tax rate. 2. Ratings represent Athene OpCo credit ratings. 3. Includes excess capital and untapped debt capacity.

APOLLO INVESTOR DAY 2021

INVESTOR
DAY 2021

Reconciliation of GAAP to Non-GAAP Measures



Total Segment Results & Share Reconciliation

APOLLO

(\$ in thousands, except where noted)	FY'16	FY'17	FY'18	FY'19	FY'20	Q2'21 LTM
Management fees	\$977,649	\$1,082,315	\$1,282,688	\$1,491,070	\$1,647,964	\$1,774,679
Advisory and transaction fees, net	147,115	117,624	111,567	122,890	251,520	291,769
Performance fees ¹	22,941	17,666	28,390	21,110	9,836	20,838
Total Fee Related Revenues	1,147,705	1,217,605	1,422,645	1,635,070	1,909,320	2,087,286
Salary, bonus and benefits	(366,890)	(394,155)	(414,962)	(463,316)	(560,987)	(623,496)
General, administrative and other	(218,490)	(228,579)	(239,291)	(273,004)	(303,883)	(318,966)
Placement fees	(24,433)	(13,913)	(2,122)	(1,085)	(1,814)	(2,109)
Total Fee Related Expenses	(609,813)	(636,647)	(656,375)	(737,405)	(866,684)	(944,571)
Other income (loss), net of Non-Controlling Interest	(8,018)	43,455	4,969	4,537	(2,109)	(1,223)
Fee Related Earnings	\$529,874	\$624,413	\$771,239	\$902,202	\$1,040,527	\$1,141,492
Realized performance fees	251,946	631,359	380,188	602,106	280,923	779,850
Realized profit sharing expense	(136,793)	(278,838)	(225,629)	(290,252)	(190,307)	(418,033)
Net Realized Performance Fees	115,153	352,521	154,559	311,854	90,616	361,817
Realized principal investment income, net ²	37,180	68,242	69,711	65,697	22,851	108,824
Net interest loss and other	(44,203)	(48,353)	(42,030)	(65,326)	(134,514)	(138,896)
Segment Distributable Earnings	\$638,004	\$996,823	\$953,479	\$1,214,427	\$1,019,480	\$1,473,237
Taxes and related payables	(9,635)	(26,337)	(44,215)	(62,300)	(89,989)	(118,717)
Preferred dividends	-	(13,538)	(31,662)	(36,656)	(36,656)	(36,655)
Distributable Earnings	\$628,369	\$956,948	\$877,602	\$1,115,471	\$892,835	\$1,317,865
	FY'16	FY'17	FY'18	FY'19	FY'20	YTD Q2'21
Total GAAP Class A Common Stock Outstanding	185,460,294	195,267,669	201,400,500	222,994,407	228,873,449	231,366,321
Non-GAAP Adjustments:						
Apollo Operating Group Units	215,457,239	207,739,821	202,345,561	180,111,308	204,028,327	201,208,132
Vested RSUs	2,752,455	2,802,277	2,380,783	2,349,618	1,833,332	359,592
Unvested RSUs Eligible for Dividend Equivalents	6,304,061	3,563,604	7,382,478	6,610,369	6,275,957	7,858,538
Distributable Earnings Shares Outstanding	409,974,049	409,373,371	413,509,322	412,065,702	441,011,065	440,792,583

1. Represents certain performance related to business development companies, Redding Ridge Holdings LP ("Redding Ridge Holdings"), an affiliate of Redding Ridge, and MidCap.

2. Realized principal investment income, net includes dividends from our permanent capital vehicles, net of amounts to be distributed to certain employees as part of a dividend compensation program.

Reconciliation of GAAP to Non-GAAP Financial Measures

APOLLO

(\$ in thousands, except where noted)	FY'16	FY'17	FY'18	FY'19	FY'20	Q2'21 LTM
Net Income (Loss) Attributable to AGM Class A Common Stockholders	\$402,850	\$615,566	(\$42,038)	\$806,537	\$119,958	\$2,006,465
Preferred dividends	-	13,538	31,662	36,656	36,656	36,655
Net income (loss) attributable to Non-Controlling Interests in consolidated entities	5,789	8,891	31,648	30,504	118,378	428,573
Net income (loss) attributable to Non-Controlling Interests in the Apollo Operating Group	561,668	805,644	(2,021)	663,146	191,810	2,303,830
GAAP Net Income	\$970,307	\$1,443,639	\$19,251	\$1,536,843	\$466,802	\$4,775,523
Income tax provision (benefit)	90,707	325,945	86,021	(128,994)	86,966	639,793
GAAP Income Before Income Tax Provision (Benefit)	\$1,061,014	\$1,769,584	\$105,272	\$1,407,849	\$553,768	\$5,415,316
Transaction related charges ¹	55,302	17,496	(5,631)	49,213	39,186	80,141
Charges associated with corporate conversion	-	-	-	21,987	3,893	2,829
(Gains) losses from remeasurement of tax receivable agreement liability	(3,208)	(200,240)	(35,405)	50,307	(12,426)	(14,367)
Net (income) loss attributable to Non-Controlling Interests in consolidated entities	(5,789)	(8,891)	(31,648)	(30,504)	(118,378)	(428,573)
Unrealized performance fees	(510,999)	(688,565)	782,888	(434,582)	(34,796)	(2,497,570)
Unrealized profit sharing expense	179,857	226,319	(274,812)	207,592	33,350	1,060,979
Equity-based profit sharing expense and other ²	3,127	6,980	91,051	96,208	129,084	117,997
Equity-based compensation	63,081	64,954	68,229	70,962	67,852	71,684
Unrealized principal investment (income) loss	(65,401)	(94,709)	62,097	(88,576)	(62,485)	(529,338)
Unrealized net (gains) losses from investment activities and other	(138,980)	(96,105)	191,438	(136,029)	420,432	(1,805,861)
Segment Distributable Earnings	\$638,004	\$996,823	\$953,479	\$1,214,427	\$1,019,480	\$1,473,237
Taxes and related payables	(9,635)	(26,337)	(44,215)	(62,300)	(89,989)	(118,717)
Preferred dividends	-	(13,538)	(31,662)	(36,656)	(36,656)	(36,655)
Distributable Earnings	\$628,369	\$956,948	\$877,602	\$1,115,471	\$892,835	\$1,317,865
Preferred dividends	-	13,538	31,662	36,656	36,656	36,655
Taxes and related payables	9,635	26,337	44,215	62,300	89,989	118,717
Realized performance fees	(251,946)	(631,359)	(380,188)	(602,106)	(280,923)	(779,850)
Realized profit sharing expense	136,793	278,838	225,629	290,252	190,307	418,033
Realized principal investment income, net	(37,180)	(68,242)	(69,711)	(65,697)	(22,851)	(108,824)
Net interest loss and other	44,203	48,353	42,030	65,326	134,514	138,896
Fee Related Earnings	\$529,874	\$624,413	\$771,239	\$902,202	\$1,040,527	\$1,141,492

1. Transaction-related charges include equity-based compensation charges, the amortization of intangible assets, contingent consideration and certain other charges associated with acquisitions, and restructuring charges.

2. Equity-based profit sharing expense and other includes certain profit sharing arrangements in which a portion of performance fees distributed to the general partner are allocated by issuance of equity-based awards, rather than cash, to employees of Apollo. Equity-based profit sharing expense and other also includes non-cash expenses related to equity awards granted by unconsolidated related parties to employees of Apollo.

APOLLO INVESTOR DAY 2021

Reconciliation of GAAP to Non-GAAP Financial Measures

ATHENE

RECONCILIATION OF NET INCOME (LOSS) AVAILABLE TO AHL COMMON SHAREHOLDERS TO ADJUSTED OPERATING INCOME AVAILABLE TO COMMON SHAREHOLDERS EXCLUDING AOG (QUARTERLY)

(in millions)	Quarterly											
	3Q'18	4Q'18	1Q'19	2Q'19	3Q'19	4Q'19	1Q'20	2Q'20	3Q'20	4Q'20	1Q'21	2Q'21
Net income (loss) available to AHL common shareholders	\$ 623	\$ (104)	\$ 708	\$ 720	\$ 276	\$ 432	\$ (1,065)	\$ 824	\$ 622	\$ 1,065	\$ 578	\$ 1,382
Non-operating adjustments												
Investment gains (losses), net of offsets	(53)	(114)	458	417	166	(47)	(1,139)	775	346	526	(605)	517
Change in fair values of derivatives and embedded derivatives – FIAs, net of offsets	376	(288)	(27)	(57)	(117)	136	65	(405)	72	33	488	(68)
Integration, restructuring and other non-operating expenses	(2)	(4)	(1)	(11)	(34)	(24)	(4)	(9)	-	3	(45)	(11)
Stock compensation expense	(3)	(3)	(3)	(3)	(3)	(3)	(10)	-	(1)	-	-	(1)
Income tax (expense) benefit – non-operating	(66)	65	(6)	4	21	(19)	131	(27)	(97)	(55)	(8)	(55)
Less: Total non-operating adjustments	252	(344)	421	350	33	43	(957)	334	320	507	(170)	382
Adjusted operating income (loss) available to common shareholders	371	240	287	370	243	389	(108)	490	302	558	748	1,000
Less: Change in fair value of Apollo investment, net of tax	-	-	-	-	-	-	(239)	372	(81)	113	(19)	373
Adjusted operating income available to common shareholders excluding AOG	\$ 371	\$ 240	\$ 287	\$ 370	\$ 243	\$ 389	\$ 131	\$ 118	\$ 383	\$ 445	\$ 767	\$ 627
Consolidated average net invested assets ex. Apollo investment	\$ 99,603	\$ 109,423	\$ 112,402	\$ 115,221	\$ 118,905	\$ 115,986	\$ 118,919	\$ 126,510	\$ 138,797	\$ 145,251	\$ 151,644	\$ 156,753

Reconciliation of GAAP to Non-GAAP Financial Measures

ATHENE

RECONCILIATION OF NET INCOME AVAILABLE TO AHL COMMON SHAREHOLDERS TO ADJUSTED OPERATING INCOME AVAILABLE TO COMMON SHAREHOLDERS EXCLUDING AOG (ANNUAL)

(in millions)	Annual							
	2014	2015	2016	2017	2018	2019	2020	Q2'21 YTD
Net income available to AHL common shareholders	\$ 471	\$ 579	\$ 773	\$ 1,358	\$ 1,053	\$ 2,136	\$ 1,446	\$ 1,960
Non-operating adjustments:								
Investment gains (losses), net of offsets	152	(56)	47	199	(274)	994	508	(88)
Change in fair values of derivatives and embedded derivatives - FIAs, net of offsets	(28)	(30)	67	230	242	(65)	(235)	420
Integration, restructuring and other non-operating expenses	(279)	(58)	(22)	(68)	(22)	(70)	(10)	(56)
Stock compensation expense	(148)	(67)	(82)	(33)	(11)	(12)	(11)	(1)
Income tax (expense) benefit - non-operating	(24)	30	4	(25)	(22)	-	(48)	(63)
Less: Total non-operating adjustments	(327)	(181)	14	303	(87)	847	204	212
Adjusted operating income available to common shareholders	798	760	759	1,055	1,140	1,289	1,242	1,748
Less: Change in fair value of Apollo investment, net of tax	-	-	-	-	-	-	165	354
Adjusted operating income available to common shareholders, excluding AOG	\$ 798	\$ 760	\$ 759	\$ 1,055	\$ 1,140	\$ 1,289	\$ 1,077	\$ 1,394
Adjusted operating income available to common shareholders, excluding AOG, by segment								
Retirement Services	\$ 769	\$ 789	\$ 808	\$ 1,038	\$ 1,201	\$ 1,322	\$ 1,266	\$ 1,418
Corporate and Other	29	(29)	(49)	17	(61)	(33)	(189)	(24)
Adjusted operating income available to common shareholders, excluding AOG	\$ 798	\$ 760	\$ 759	\$ 1,055	\$ 1,140	\$ 1,289	\$ 1,077	\$ 1,394

Reconciliation of GAAP to Non-GAAP Financial Measures

ATHENE

RECONCILIATION OF NET INCOME AVAILABLE TO AHL COMMON SHAREHOLDERS TO NORMALIZED ADJUSTED OPERATING INCOME AVAILABLE TO COMMON SHAREHOLDERS EXCLUDING AOG, TAX AND NOTABLES

(in millions)	Annual						
	2015	2016	2017	2018	2019	2020	Q2'21 LTM
Net income available to AHL common shareholders	\$ 579	\$ 773	\$ 1,358	\$ 1,053	\$ 2,136	\$ 1,446	\$ 3,647
Non-operating adjustments:							
Investment gains (losses), net of offsets	(56)	47	199	(274)	994	508	784
Change in fair values of derivatives and embedded derivatives - FIAs, net of offsets	(30)	67	230	242	(65)	(235)	525
Integration, restructuring and other non-operating expenses	(58)	(22)	(68)	(22)	(70)	(10)	(53)
Stock compensation expense	(67)	(82)	(33)	(11)	(12)	(11)	(2)
Income tax (expense) benefit - non-operating	30	4	(25)	(22)	-	(48)	(215)
Less: Total non-operating adjustments	(181)	14	303	(87)	847	204	1,039
Adjusted operating income available to common shareholders	760	759	1,055	1,140	1,289	1,242	2,608
Less: Change in fair value of Apollo investment, net of tax	-	-	-	-	-	165	386
Adjusted operating income available to common shareholders, excluding AOG	760	759	1,055	1,140	1,289	1,077	2,222
Less: Income tax (expense) benefit - operating	(30)	57	(81)	(100)	(117)	(164)	(220)
Adjusted operating income available to common shareholders, excluding AOG and tax	790	702	1,136	1,240	1,406	1,241	2,442
Less: Long-term incentive plan compensation expense	-	(2)	(12)	(15)	(15)	(14)	(32)
Adjusted operating income available to common shareholders, excluding AOG, tax and LTIP expense	790	704	1,148	1,255	1,421	1,255	2,474
Long-term alternative investment return adjustment, net of offsets	127	99	59	91	37	152	(660)
Notable items:							
Proceeds from bond previously written down	-	-	(14)	-	-	-	-
Non-recurring adjustment on derivative collateral	-	-	-	-	-	(18)	(25)
Actuarial experience and market impacts	-	-	(152)	21	(43)	(16)	(112)
Unlocking	(24)	158	20	13	48	(6)	(6)
Total notable items, pre-tax	(24)	158	(146)	34	5	(40)	(143)
Normalized adjusted operating income available to common shareholders, excluding AOG, tax and notables	\$ 893	\$ 961	\$ 1,061	\$ 1,380	\$ 1,463	\$ 1,367	\$ 1,671

Reconciliation of GAAP to Non-GAAP Financial Measures

ATHENE

RECONCILIATION OF AVERAGE AHL SHAREHOLDERS' EQUITY TO AVERAGE ADJUSTED AHL COMMON SHAREHOLDERS' EQUITY

(in millions)	Annual							Q2'21 YTD
	2014	2015	2016	2017	2018	2019	2020	
Average AHL shareholders' equity	\$ 3,648	\$ 4,959	\$ 6,124	\$ 8,029	\$ 8,726	\$ 10,834	\$ 14,528	\$ 18,651
Less: Average preferred stock	-	-	-	-	-	586	1,633	2,312
Less: Average AOCI	359	203	63	908	489	905	2,030	3,110
Less: Average accumulated change in fair value of reinsurance assets	100	58	41	112	43	209	575	839
Average adjusted AHL common shareholders' equity	\$ 3,189	\$ 4,698	\$ 6,020	\$ 7,009	\$ 8,194	\$ 9,134	\$ 10,290	\$ 12,390
Average adjusted AHL common shareholders' equity by Segment								
Retirement Services	\$ 2,262	\$ 3,333	\$ 4,186	\$ 4,823	\$ 6,522	\$ 7,625	\$ 7,491	\$ 8,690
Corporate and Other	927	1,365	1,834	2,186	1,672	1,509	2,799	3,700
Average adjusted AHL common shareholders' equity	\$ 3,189	\$ 4,698	\$ 6,020	\$ 7,009	\$ 8,194	\$ 9,134	\$ 10,290	\$ 12,390

Reconciliation of GAAP to Non-GAAP Financial Measures

ATHENE

RECONCILIATION OF CLASS A COMMON SHARES OUTSTANDING TO ADJUSTED OPERATING COMMON SHARES OUTSTANDING

(in millions)	2009	2Q'21
Class A common shares outstanding	0.1	191.6
Conversion of Class B common shares to Class A common shares	9.7	-
Effect of other stock compensation plans	-	8.1
Adjusted operating common shares outstanding	9.8	199.7

RECONCILIATION OF BOOK VALUE PER COMMON SHARE TO ADJUSTED BOOK VALUE PER COMMON SHARE

	2009	2Q'21
Book value per common share	\$ 11.62	\$ 92.33
AOCI	(0.13)	(17.41)
Accumulated change in fair value of reinsurance assets	-	(4.62)
Effect of items convertible to or settled in Class A common shares	-	(2.04)
Adjusted book value per common share	\$ 11.49	\$ 67.46

RECONCILIATION OF TOTAL AHL SHAREHOLDERS' EQUITY TO TOTAL ADJUSTED AHL COMMON SHAREHOLDERS' EQUITY

(in millions)	2009	2Q'21
Total AHL shareholders' equity	\$ 113	\$ 20,006
Less: Preferred stock	-	2,312
Total AHL common shareholders' equity	113	17,694
Less: AOCI	1	3,337
Less: Accumulated change in fair value of reinsurance assets	-	886
Total adjusted AHL common shareholders' equity	\$ 112	\$ 13,471

RECONCILIATION OF DEBT TO CAPITAL RATIO TO ADJUSTED DEBT TO CAPITAL RATIO

(in millions, except percentages)	2Q'21
Total debt	\$ 2,468
Total AHL shareholders' equity	20,006
Total capitalization	22,474
Less: Accumulated other comprehensive income (AOCI)	3,337
Less: Accumulated change in fair value of reinsurance assets	886
Total adjusted capitalization	\$ 18,251
Debt to capital ratio	11.0%
AOCI	2.0%
Accumulated change in fair value of reinsurance assets	0.5%
Adjusted debt to capital ratio	13.5%

Reconciliation of GAAP to Non-GAAP Financial Measures

ATHENE

RECONCILIATION OF NET INVESTMENT INCOME TO NET INVESTMENT EARNINGS

(in millions)	Quarterly											
	3Q'18	4Q'18	1Q'19	2Q'19	3Q'19	4Q'19	1Q'20	2Q'20	3Q'20	4Q'20	1Q'21	2Q'21
GAAP net investment income	\$ 1,085	\$ 1,138	\$ 1,082	\$ 1,182	\$ 1,090	\$ 1,242	\$ 745	\$ 1,336	\$ 1,209	\$ 1,595	\$ 1,704	\$ 2,038
Change in fair value of reinsurance assets	52	132	132	161	199	188	270	218	444	476	366	388
Alternative income gain (loss)	(14)	(20)	(5)	12	6	(12)	(101)	56	23	(80)	69	(18)
ACRA noncontrolling interest	-	-	-	-	-	(61)	(72)	(81)	(196)	(210)	(198)	(219)
Apollo investment (income) loss	-	-	-	-	-	-	297	(481)	101	(142)	25	(472)
Held for trading amortization and other	3	(46)	(6)	(10)	(3)	(18)	12	(8)	(51)	(32)	32	9
Total adjustments to arrive at net investment earnings	41	66	121	163	202	97	406	(296)	321	12	294	(312)
Total net investment earnings	\$ 1,126	\$ 1,204	\$ 1,203	\$ 1,345	\$ 1,292	\$ 1,339	\$ 1,151	\$ 1,040	\$ 1,530	\$ 1,607	\$ 1,998	\$ 1,726

RECONCILIATION OF NET INVESTMENT INCOME RATE TO NET INVESTMENT EARNED RATE

	Quarterly											
	3Q'18	4Q'18	1Q'19	2Q'19	3Q'19	4Q'19	1Q'20	2Q'20	3Q'20	4Q'20	1Q'21	2Q'21
GAAP net investment income rate	4.36%	4.16%	3.85%	4.10%	3.67%	4.28%	2.51%	4.22%	3.48%	4.39%	4.49%	5.20%
Change in fair value of reinsurance assets	0.20%	0.48%	0.47%	0.56%	0.67%	0.65%	0.90%	0.69%	1.28%	1.31%	0.97%	0.99%
Alternative income gain (loss)	-0.06%	-0.07%	-0.02%	0.04%	0.02%	-0.04%	-0.34%	0.18%	0.07%	-0.22%	0.18%	-0.05%
ACRA noncontrolling interest	0.00%	0.00%	0.00%	0.00%	0.00%	-0.21%	-0.24%	-0.26%	-0.56%	-0.58%	-0.52%	-0.56%
Apollo investment (income) loss	0.00%	0.00%	0.00%	0.00%	0.00%	0.00%	1.00%	-1.52%	0.29%	-0.38%	0.07%	-1.20%
Held for trading amortization and other	0.02%	-0.17%	-0.02%	-0.03%	-0.01%	-0.06%	0.04%	-0.02%	-0.15%	-0.09%	0.08%	0.02%
Total adjustments to arrive at net investment earned rate	0.16%	0.24%	0.43%	0.57%	0.68%	0.34%	1.36%	-0.93%	0.93%	0.04%	0.78%	-0.80%
Consolidated net investment earned rate	4.52%	4.40%	4.28%	4.67%	4.35%	4.62%	3.87%	3.29%	4.41%	4.43%	5.27%	4.40%
Consolidated average net invested assets ex. Apollo investment	\$ 99,603	\$ 109,423	\$ 112,402	\$ 115,221	\$ 118,905	\$ 115,986	\$ 118,919	\$ 126,510	\$ 138,797	\$ 145,251	\$ 151,644	\$ 156,753

APOLLO INVESTOR DAY 2021

Reconciliation of GAAP to Non-GAAP Financial Measures

ATHENE

RECONCILIATION OF INTEREST SENSITIVE CONTRACT BENEFITS TO COST OF CREDITING

(in millions, except percentages)	Quarterly											
	3Q'18	4Q'18	1Q'19	2Q'19	3Q'19	4Q'19	1Q'20	2Q'20	3Q'20	4Q'20	1Q'21	2Q'21
GAAP interest sensitive contract benefits	\$ 742	\$ (825)	\$ 1,516	\$ 1,094	\$ 801	\$ 1,146	\$ (1,319)	\$ 2,076	\$ 1,225	\$ 1,909	\$ 394	\$ 1,979
Interest credited other than deferred annuities and institutional products	14	35	55	50	63	64	63	75	73	101	97	94
FIA option costs	231	275	278	280	282	269	266	271	284	280	279	278
Product charges (strategy fees)	(25)	(28)	(28)	(29)	(31)	(31)	(32)	(34)	(34)	(36)	(38)	(40)
Reinsurance embedded derivative impacts	29	14	15	14	14	14	14	15	14	14	14	12
Change in fair values of embedded derivatives - FIAs	(546)	1,039	(1,311)	(868)	(560)	(905)	1,504	(1,734)	(779)	(1,395)	43	(1,480)
Negative VOBA amortization	5	9	12	7	9	8	7	5	3	6	3	5
ACRA noncontrolling interest	-	-	-	-	-	(42)	38	(113)	(151)	(207)	(128)	(180)
Other changes in interest sensitive contract liabilities	3	(3)	(2)	(1)	(2)	(2)	(1)	(1)	5	5	4	10
Total adjustments to arrive at cost of crediting	(289)	1,341	(981)	(547)	(225)	(625)	1,859	(1,516)	(585)	(1,232)	274	(1,301)
Cost of crediting	\$ 453	\$ 516	\$ 535	\$ 547	\$ 576	\$ 521	\$ 540	\$ 560	\$ 640	\$ 677	\$ 668	\$ 678
GAAP interest sensitive contract benefits	2.98%	-3.02%	5.39%	3.80%	2.69%	3.95%	-4.44%	6.56%	3.53%	5.26%	1.04%	5.05%
Interest credited other than deferred annuities and institutional products	0.05%	0.13%	0.20%	0.17%	0.21%	0.22%	0.21%	0.24%	0.21%	0.28%	0.25%	0.24%
FIA option costs	0.93%	1.01%	0.99%	0.97%	0.95%	0.93%	0.90%	0.86%	0.82%	0.77%	0.74%	0.71%
Product charges (strategy fees)	-0.10%	-0.10%	-0.10%	-0.10%	-0.10%	-0.11%	-0.11%	-0.11%	-0.10%	-0.10%	-0.10%	-0.10%
Reinsurance embedded derivative impacts	0.12%	0.05%	0.05%	0.05%	0.05%	0.05%	0.05%	0.05%	0.04%	0.04%	0.04%	0.03%
Change in fair values of embedded derivatives - FIAs	-2.19%	3.80%	-4.66%	-3.01%	-1.88%	-3.12%	5.06%	-5.48%	-2.24%	-3.84%	0.11%	-3.78%
Negative VOBA amortization	0.02%	0.03%	0.04%	0.02%	0.03%	0.03%	0.02%	0.01%	0.01%	0.01%	0.01%	0.01%
ACRA noncontrolling interest	0.00%	0.00%	0.00%	0.00%	0.00%	-0.14%	0.13%	-0.36%	-0.44%	-0.57%	-0.34%	-0.46%
Other changes in interest sensitive contract liabilities	0.01%	-0.01%	-0.01%	0.00%	-0.01%	-0.01%	0.00%	0.00%	0.01%	0.01%	0.01%	0.03%
Total adjustments to arrive at cost of crediting	-1.16%	4.91%	-3.49%	-1.90%	-0.75%	-2.15%	6.26%	-4.79%	-1.69%	-3.40%	0.72%	-3.32%
Cost of crediting	1.82%	1.89%	1.90%	1.90%	1.94%	1.80%	1.82%	1.77%	1.84%	1.86%	1.76%	1.73%
Consolidated average net invested assets ex. Apollo investment	\$ 99,603	\$ 109,423	\$ 112,402	\$ 115,221	\$ 118,905	\$ 115,986	\$ 118,919	\$ 126,510	\$ 138,797	\$ 145,251	\$ 151,644	\$ 156,753

APOLLO INVESTOR DAY 2021

Reconciliation of GAAP to Non-GAAP Financial Measures

ATHENE

RECONCILIATION OF BENEFITS AND EXPENSES TO OTHER LIABILITY COSTS

Quarterly

(in millions)	3Q'18	4Q'18	1Q'19	2Q'19	3Q'19	4Q'19	1Q'20	2Q'20	3Q'20	4Q'20	1Q'21	2Q'21
GAAP benefits and expenses	\$ 1,907	\$ 1,325	\$ 4,255	\$ 2,673	\$ 4,305	\$ 2,723	\$ (167)	\$ 3,317	\$ 2,251	\$ 7,157	\$ 4,252	\$ 4,433
Premiums	(536)	(1,857)	(2,000)	(787)	(2,688)	(907)	(1,140)	(355)	(112)	(4,356)	(3,011)	(1,598)
Product Charges	(119)	(128)	(125)	(132)	(135)	(132)	(140)	(141)	(144)	(146)	(150)	(157)
Other revenues	(10)	(4)	(12)	(9)	(6)	(10)	2	(18)	(13)	(7)	(14)	(20)
Cost of crediting	(193)	(227)	(242)	(253)	(280)	(238)	(259)	(275)	(342)	(383)	(375)	(388)
Change in fair value of embedded derivatives - FIA, net of offsets	(768)	1,266	(1,260)	(817)	(497)	(1,003)	1,456	(1,445)	(863)	(1,409)	(298)	(1,450)
DAC, DSI, and VOBA amortization related to investment gains and losses	28	36	(173)	(181)	(151)	28	425	(323)	(86)	(111)	139	(94)
Rider reserves	1	8	(28)	(24)	(9)	3	76	(46)	(21)	(19)	21	(20)
Policy and other operating expenses, excluding policy acquisition expenses	(98)	(102)	(103)	(117)	(130)	(138)	(117)	(145)	(132)	(139)	(201)	(168)
AmerUs closed block fair value liability	8	14	(53)	(59)	(46)	6	45	(100)	(15)	(34)	93	(54)
ACRA noncontrolling interest	-	-	-	-	-	(74)	165	(241)	(193)	(258)	(107)	(242)
Other	1	1	1	1	(5)	1	(4)	(13)	(10)	(14)	(7)	5
Total adjustments to arrive at other liability costs	(1,686)	(993)	(3,995)	(2,378)	(3,947)	(2,464)	509	(3,102)	(1,931)	(6,876)	(3,910)	(4,186)
Other liability costs	\$ 221	\$ 332	\$ 260	\$ 295	\$ 358	\$ 259	\$ 342	\$ 215	\$ 320	\$ 281	\$ 342	\$ 247

Reconciliation of GAAP to Non-GAAP Financial Measures

ATHENE

RECONCILIATION OF POLICY AND OTHER OPERATING EXPENSES TO OPERATING EXPENSES												
Quarterly												
(in millions)	3Q'18	4Q'18	1Q'19	2Q'19	3Q'19	4Q'19	1Q'20	2Q'20	3Q'20	4Q'20	1Q'21	2Q'21
Policy and other operating expenses	\$ 158	\$ 172	\$ 165	\$ 185	\$ 194	\$ 200	\$ 188	\$ 218	\$ 231	\$ 218	\$ 283	\$ 242
Interest expense	(15)	(13)	(17)	(15)	(15)	(20)	(20)	(29)	(34)	(31)	(32)	(34)
Policy acquisition expenses, net of deferrals	(60)	(70)	(62)	(69)	(63)	(62)	(71)	(73)	(99)	(79)	(82)	(74)
Integration, restructuring and other non-operating expenses	(2)	(4)	(1)	(11)	(34)	(24)	(4)	(9)	-	3	(45)	(11)
Stock compensation expenses	(3)	(3)	(3)	(3)	(3)	(3)	(10)	-	(1)	-	-	(1)
ACRA noncontrolling interest	-	-	-	-	-	(5)	(4)	(19)	(16)	(19)	(21)	(19)
Other changes in policy and other operating expenses	-	-	-	-	-	-	-	-	(3)	1	(5)	(8)
Total adjustments to arrive at operating expenses	(80)	(90)	(83)	(98)	(115)	(114)	(109)	(130)	(153)	(125)	(185)	(147)
Operating expenses	\$ 78	\$ 82	\$ 82	\$ 87	\$ 79	\$ 86	\$ 79	\$ 88	\$ 78	\$ 93	\$ 98	\$ 95

Reconciliation of GAAP to Non-GAAP Financial Measures

ATHENE

RECONCILIATION OF TOTAL INVESTMENTS INCLUDING RELATED PARTIES TO NET INVESTED ASSETS	
	Quarterly
(in millions)	2Q'21
Total investments including related parties	\$ 194,509
Derivative assets	(4,151)
Cash and cash equivalents (including restricted cash)	8,726
Accrued investment income	1,010
Payables for collateral on derivatives	(3,890)
Reinsurance funds withheld and modified coinsurance	(1,699)
VIE and VOE assets, liabilities and noncontrolling interest	(281)
Unrealized (gains)/losses	(5,960)
Ceded policy loans	(179)
Net investment receivables (payables)	328
Allowance for credit losses	338
Total adjustments to arrive at invested assets	(5,758)
Gross invested assets	188,751
ACRA noncontrolling interest	(27,937)
Net invested assets	\$ 160,814

RECONCILIATION OF INVESTMENT FUNDS INCLUDING RELATED PARTIES TO NET ALTERNATIVE INVESTMENTS	
	Quarterly
(in millions)	2Q'21
Investment funds including related parties	\$ 7,483
Nonredeemable preferred stock included in equity securities	226
CLO and ABS equities included in trading securities	1,160
Investment in Apollo	(1,730)
Investment funds within funds withheld at interest	1,646
Royalties and other assets included in other investments	(76)
Unrealized (gains)/losses and other adjustments	(32)
Total adjustments to arrive at alternative investments	1,194
Gross alternative investments	8,677
ACRA noncontrolling interest	(846)
Net alternative investments	\$ 7,831

RECONCILIATION OF TOTAL LIABILITIES TO NET RESERVE LIABILITIES	
	Quarterly
(in millions)	2Q'21
Total liabilities	\$ 193,878
Long-term debt	(2,468)
Derivative liabilities	(214)
Payables for collateral on derivatives and securities to repurchase	(3,890)
Funds withheld liability	(437)
Other liabilities	(2,413)
Reinsurance ceded receivables	(4,627)
Policy loans ceded	(179)
Other	(7)
Total adjustments to arrive at reserve liabilities	(14,235)
Gross reserve liabilities	179,643
ACRA noncontrolling interest	(26,871)
Net reserve liabilities	\$ 152,772

INVESTOR
DAY 2021

Important Information & Definitions



Important Information

Estimates and Assumptions

This presentation includes certain unaudited financial and business projections and goals on Apollo's future outlook following the closing of the transaction with Athene and the creation of three reportable segments (the "Estimates").

Apollo does not regularly provide future guidance or publicly disclose forecasts or projections as to future performance, earnings or other results due to the inherent unpredictability of projections and their underlying assumptions and estimates. The Estimates were not prepared with a view toward public disclosure and, accordingly, do not necessarily comply with published guidelines of the SEC or the guidelines established by the American Institute of Certified Public Accountants for preparation and presentation of financial forecasts or GAAP. Neither Apollo's independent registered public accounting firm, nor any other independent accountants, have audited, reviewed, compiled or performed any procedures with respect to the Estimates or expressed any opinion or any form of assurance related thereto. Additionally, the Estimates are not intended to be pro forma financial information prepared in compliance with Article 11 of Regulation S-X.

The Estimates reflect the internal financial model that Apollo uses in connection with its strategic planning, after giving effect to the transaction with Athene. The Estimates are illustrative and are included in this presentation solely to give Apollo's investors access to these financial projections. They are not being included in this presentation to influence a stockholder's decision whether to vote for the Apollo-Athene merger.

The Estimates are distinct, and differ in material respects, from the various financial projections that were provided to Barclays, Houlihan Lokey or Lazard in connection with the financial analysis each performed on the Apollo-Athene merger. For more information on those separate projections, please refer to the joint proxy statement/prospectus filed by HoldCo with the SEC in connection with the Apollo-Athene merger.

The Estimates were based on numerous variables and assumptions made by Apollo's management with respect to industry performance, general business, economic, regulatory, market and financial conditions and other future events, as well as matters specific to Apollo's and Athene's businesses, all of which are difficult or impossible to predict accurately and many of which are beyond the control of Apollo's management. Because the Estimates cover multiple years, by their nature, they also become subject to greater uncertainty and are less reliable with each successive year. The Estimates reflect subjective judgment in many respects and thus are susceptible to multiple interpretations and periodic revisions based on actual experience and business developments. As such, the Estimates constitute forward-looking information and are subject to many risks and uncertainties that could cause actual results to differ materially from the results forecasted in these projections. There can be no assurance that the Estimates will be realized or that actual results will not be significantly higher or lower than forecast. The Estimates may be affected by Apollo's and Athene's ability to achieve strategic goals, objectives and targets over the applicable period. Please consider carefully the section above titled "Forward Looking Statements". Accordingly, there can be no assurance that the Estimates will be realized, and actual results may vary materially from those shown. The Estimates cannot, therefore, be considered a guarantee of future operating results, and this information should not be relied on as such.

The inclusion of the Estimates in this presentation should not be regarded as an indication that Apollo or any of its affiliates, advisors, officers, directors or representatives considered or considers the Estimates to be necessarily predictive of actual future events, and the Estimates should not be relied upon as such. The inclusion of the Estimates herein should not be deemed an admission or representation by Apollo that its management views the Estimates as material information. Neither Apollo nor Athene or any of their respective affiliates, advisors, officers, directors or representatives has made or makes any representation to any of Apollo's stockholders or any other person regarding the ultimate performance of Apollo or Athene compared to the information contained in the Estimates or can give any assurance that actual results will not differ materially from the Estimates, and none of them undertakes any obligation to update or otherwise revise or reconcile the Estimates to reflect circumstances existing after the date the Estimates were generated or to reflect the occurrence of future events even in the event that any or all of the assumptions underlying the Estimates are shown to be in error.

Certain of the projected financial information set forth herein may be considered non-GAAP financial measures. There are limitations inherent in non-GAAP financial measures, because they exclude charges and credits that are required to be included in a GAAP presentation. Non-GAAP financial measures should not be considered in isolation from, or as a substitute for, financial information presented in compliance with GAAP, and non-GAAP financial measures as used by Apollo may not be comparable to similarly titled amounts used by other companies. No reconciliation of non-GAAP financial measures in the Estimates to GAAP measures was created or used in connection with preparing the Estimates.

In light of the foregoing factors and the uncertainties inherent in the Estimates, Apollo's and Athene stockholders are cautioned not to place undue reliance on the Estimates. Without limiting the statements made in the prior paragraphs, please take note of the following additional important information.

Important Information

Assets Under Management ("AUM")

The estimates and expectations about new fund capital that Apollo can raise in various strategies and formats (including permanent capital) and Apollo's AUM in the future depend on many assumptions about future events and circumstances, including but not limited to the fundraising environment generally, investor interest in the investment strategies presented, and the expected pace and the time periods within which fundraising will be completed. There are many factors that could delay, impede or prohibit the future fundraising that AGM currently expects, including not limited to market disruption, loss of key personnel, lack of investor interest, negotiations with investors, and other events or circumstances that we may or may not be able to predict, manage or control (including but not limited to the matters discussed under the section "Forward Looking Statements" above).

Fee Related Earnings ("FRE"), Spread Related Earnings ("SRE") and Principal Investing Income ("PII")

The estimates and expectations about Apollo's fees, FRE, SRE and PII in the future depend on many assumptions about future events and circumstances, including but not limited to (i) the assumptions about future fundraising and AUM, (ii) the actual terms and conditions of the Apollo Funds to be raised in the future, including management fee rates paid, (iii) the investment and transaction activity of Apollo entities, (iv) the ability to generate liability growth, realize target returns and target net spreads on Athene's investment portfolio, (v) the variability and level of our operating expenses, and (vi) the timing and amounts generated by the monetization of investments held by Apollo entities. The value of unrealized investment gains and unrealized carried interest may be volatile and subject to material change, and the actual realized value of currently unrealized investments will depend on, among other factors, the value of the investments and market conditions at the time of disposition, legal and contractual restrictions, transaction costs, and the timing and manner of sale, all of which may differ from the assumptions used for this presentation. Accordingly, the actual realized values of unrealized investments and carried interest may differ materially from the values assumed by Apollo for purposes of this presentation. The actual realized returns and net spreads on Athene's investments can be highly dependent on future interest rates. There are many factors that could delay, impede or prohibit Apollo's ability to generate the future fees, FRE, SRE and PII that Apollo currently expects, including but not limited to market disruption, loss of key personnel, lack of investor or third party interest, negotiations by investors or other third parties, unexpected expenses, and other events or circumstances that we may or may not be able to predict, manage or control (including but not limited to the matters discussed in the section "Forward Looking Statements" above).

Distributable Earnings ("DE")

The estimates and expectations about Apollo's DE in the future depend on many assumptions about future events and circumstances, including but not limited to (i) the assumptions about future AUM, fees, FRE, SRE and PII, and (ii) possible future clawbacks, and netting holes. There are many factors that could delay, impede or prohibit Apollo's ability to generate the DE that Apollo currently expects, including but not limited to market disruption, loss of key personnel, lack of investor or third party interest, negotiations by investors or other third parties, unexpected expenses including higher income taxes resulting from changes in tax legislation, and other events or circumstances that we may or may not be able to predict, manage or control (including but not limited to the matters discussed in the section "Forward Looking Statements" above).

Business Growth

All statements relating to the potential for future business growth are inherently uncertain and are based on current market conditions, which can change at any time, and various assumptions about the ability to capitalize on growth opportunities and future business performance. No inference should be made that Apollo (including Athene) can or will grow any of its businesses materially or sufficiently to meet or approach the size of any market or sector leader disclosed in this presentation. See the section "Forward Looking Statements" above.

APOLLO DOES NOT INTEND TO UPDATE OR OTHERWISE REVISE THE ABOVE ESTIMATES TO REFLECT CIRCUMSTANCES EXISTING AFTER THE DATE WHEN MADE OR TO REFLECT THE OCCURRENCE OF FUTURE EVENTS, EVEN IN THE EVENT THAT ANY OR ALL OF THE ASSUMPTIONS UNDERLYING SUCH ESTIMATES ARE NO LONGER APPROPRIATE OR ARE SHOWN TO BE IN ERROR, EXCEPT AS MAY BE REQUIRED BY APPLICABLE LAW.

Important Information

Performance Information

Past performance is not necessarily indicative of future results and there can be no assurance that Apollo, Athene or any Apollo Fund or strategy will achieve comparable results, or that any investments made by Apollo in the future will be profitable. Actual realized value of currently unrealized investments will depend on, among other factors, future operating results, the value of the assets and market conditions at the time of disposition, any related transaction costs and the timing and manner of sale, all of which may differ from the assumptions and circumstances on which the current unrealized valuations are based. Accordingly, the actual realized values of unrealized investments may differ materially from the values indicated herein.

Information contained herein may include information with respect to prior investment performance of one or more Apollo and Athene funds or investments, including gross and/or net internal rates of return ("IRR") and gross and/or net multiple of investment cost ("MOIC"). Information with respect to prior performance, while a useful tool in evaluating investment activities, is not necessarily indicative of actual results that may be achieved for unrealized investments. The realization of such performance is dependent upon many factors, many of which are beyond the control of Apollo. Aggregated return information is not reflective of an investable product, and as such does not reflect the returns of any Apollo Fund. Certain Apollo Funds referenced herein may utilize a credit facility (sometimes referred to as a "subscription line") to make investments and pay expenses and for other purposes to the extent permitted by each Apollo Fund's partnership agreement. Such fund-level borrowing to fund investments impacts net IRR calculations because net IRR is calculated based on investor cash outlays to, and returns from, the Apollo Fund and as such, returns depend on the amount and timing of investor capital contributions.

When the Apollo Fund uses borrowed funds in advance or in lieu of calling capital, investors make correspondingly later or smaller capital contributions. Accordingly, this fund-level borrowing could result in higher net IRR (even after taking into account the associated interest expense of the borrowing) or lower net IRR, than if capital had been called to fund the investments or capital had been contributed at the inception of the investment. In addition, the Apollo Fund may pay all related expenses, including interest, on its subscription line facility and investors will bear such costs. Please refer to the Definitions pages for additional information regarding gross and net IRR.

Unless otherwise indicated, MOIC is derived from dividing the sum of the estimated remaining value and realized proceeds by the amount invested. Unless otherwise noted, MOIC is presented gross and does not reflect the effect of management fees, incentive compensation, certain expenses or taxes. Please refer to the Definitions pages for additional information regarding MOIC.

Track Record

Track record provided herein is for illustrative purposes only. The investments in the track records were selected on the basis that they fall within the scope of the investment mandate of an Apollo Fund and/or investment strategy and are intended solely as examples illustrative of the potential investment strategy of the Fund or of the types of investments that may be entered into by the Fund.

None of the examples included in the track records is necessarily indicative of all of Apollo's investment strategies or prior investment performance. While Apollo believes that the performance information herein includes applicable historical investments, there can be no assurance as to the validity, thoroughness or accuracy of Apollo's determination methodology. Moreover, while certain members of the applicable investment committee were involved in the consummation of certain of the historical representative transactions described in the track records, the sourcing of these investments and the decisions to consummate these investments were not all necessarily made by the same group of professionals, some of which may no longer be employed by Apollo, nor were such investments approved by the same investment committee.

Past performance is not indicative nor a guarantee of future results. There can be no assurance that any Apollo Fund will be able to implement its investment strategy or investment approach to achieve comparable results or that it will be successful. Moreover, there can be no assurance that any similar investment opportunities will be available or pursued by the Apollo Fund in the future.

Non-GAAP Financial Measures

This presentation contains information regarding Apollo's financial results that is calculated and presented on the basis of methodologies other than in accordance with accounting principles generally accepted in the United States ("non-GAAP measures"). The non-GAAP measures presented herein include Distributable Earnings, or "DE", Fee Related Earnings, or "FRE", Spread Related Earnings, or "SRE", and Principal Investing Income, or "PII", among others. Refer to the Definitions pages for the definitions of the non-GAAP measures presented herein, as well as Reconciliations of GAAP to Non-GAAP Measures pages for reconciliations of the most comparable GAAP measures to the non-GAAP measures.

Target Returns

Target returns including Target IRR are presented solely for providing insight into an investment's objectives and detailing anticipated risk and reward characteristics in order to facilitate comparisons with other investments and for establishing a benchmark for future evaluation of the investment's performance. Target returns are not predictions, projections or guarantees of future performance. Target returns are based upon estimates and assumptions that a potential investment will yield a return equal to or greater than the target. There can be no assurance that Apollo will be successful in finding investment opportunities that meet these anticipated return parameters. Apollo's target of potential returns from an investment is not a guarantee as to the quality of the investment or a representation as to the adequacy of Apollo's methodology for estimating returns. Target returns should not be used as a primary basis for an investor's decision to make an investment. Unless otherwise indicated, target returns are presented gross and do not reflect the effect of applicable fees, incentive compensation, certain expenses and taxes.

Important Information

Index Comparisons

Index performance and yield data are shown for illustrative purposes only and have limitations when used for comparison or for other purposes due to, among other matters, volatility, credit or other factors (such as number of investments, recycling or reinvestment of distributions, and types of assets). It may not be possible to directly invest in one or more of these indices and the holdings of any strategy may differ markedly from the holdings of any such index in terms of levels of diversification, types of securities or assets represented and other significant factors. Indices are unmanaged, do not charge any fees or expenses, assume reinvestment of income and do not employ special investment techniques such as leveraging or short selling. No such index is indicative of the future results of any strategy or Apollo Fund. Set forth below is additional information about index performance and yield data included in this presentation.

Cambridge Associates Private Investments Database ("Cambridge") publishes performance benchmarks based on quarterly unaudited and annual audited financial statements produced by over 2,000 fund managers for over 7,500 funds. These benchmarks also capture gross performance information for over 81,000 investments of venture capital, growth equity, buyout, subordinated capital and private equity energy funds. It is important to note that Cambridge's benchmarks are generally reported on a one-quarter lag from the end of the performance quarter. Therefore, this index should be considered materially different from an Apollo fund's portfolio and performance, which may have the benefit of an additional quarter of performance data. Cambridge's benchmarks have limitations when used as a basis for comparison and are therefore intended to be used solely as an illustrative proxy for performance generally in the private equity space. Additional information on Cambridge can be found [here](#).

Cambridge Associates Private Credit Index is a horizon calculation based on data compiled from 461 private credit funds, including fully-liquidated partnerships, formed between 1986 and 2018.

Cambridge Associates LLC U.S. Private Equity Index and Benchmark Statistics, as of March 31, 2021, the most recent data available, represents end-to-end pooled mean net returns to limited partners (net of fees, expenses and carried interest) for all U.S. Private Equity.

Estimated Top Quartile PE, Cambridge Associates LLC U.S. Private Equity Index and Benchmark Statistics, as of March 31, 2021, the most recent data available, is calculated by taking the 5 year, 10 year and 25 year return metrics and adding the average of the delta between Top Quartile IRRs and the Pooled Mean Net to Limited Partners for each vintage year in the selected timeframe.

Bloomberg Barclays U.S. Aggregate Bond Index ("Barclays Agg") is a market capitalization-weighted bond market index representing intermediate term investment grade bonds traded in the United States. Additional information on the Barclays Agg can be found [here](#).

CoreLogic Home Price Index ("CoreLogic HPI") represents a comprehensive and current set of home price indexes. CoreLogic HPI features over 40 years of real estate transaction data, leveraging robust housing resale data, and monthly updates to incorporate new data. Additional information on the CoreLogic HPI can be found [here](#).

S&P 500 Index ("S&P 500") is a market capitalization-weighted index of the 500 largest U.S. publicly traded companies by market value. The S&P 500 is a market value or market-capitalization-weighted index and one of the most common benchmarks for the broader U.S. equity markets. Additional information on the S&P 500 can be found [here](#).

S&P/LSTA Leveraged Loan 100 Index ("S&P LL100") is a market value-weighted index designed to measure the performance of the U.S. leveraged loan market based upon market weightings, spreads and interest payments. Additional information on the S&P LL100 can be found [here](#).

J.P. Morgan U.S. Liquid Index ("JULI") encompasses fixed rate high-grade coverage across the U.S. Additional information on the JULI can be found [here](#).

Models

Models that may be contained herein (the "Models") are being provided for illustrative and discussion purposes only and are not intended to forecast or predict future events. Information provided in the Models may not reflect the most current data and is subject to change. The Models are based on estimates and assumptions that are also subject to change and may be subject to significant business, economic and competitive uncertainties, including numerous uncontrollable market and event driven situations. There is no guarantee that the information presented in the Models is accurate. Actual results may differ materially from those reflected and contemplated in such hypothetical, forward-looking information. Undue reliance should not be placed on such information and investors should not use the Models to make investment decisions. Apollo has no duty to update the Models in the future.

Important Information

Pipeline Information

Fundraising and investment pipeline information herein is based on a number of assumptions that are subject to significant business, market, economic and competitive uncertainties, many of which are beyond Apollo's control or are subject to change. As such, there is no guarantee that the opportunities identified in the pipeline will be available in the future, launched, consummated or achieve target returns.

Funds, Products and Investments that Have Not Yet Launched/Closed

Certain Apollo Funds, products, strategies, etc. referenced herein may not have launched or closed, including but not limited to Apollo Debt Solutions BDC, Fund X and the Apollo SPAC Fund, and there can be no guarantee or assurance that they will launch or close in the future. In addition, certain transactions referenced herein, including but not limited to, the Apollo-Athene merger, FWD and Foundation, have not closed, and are subject to closing conditions. There can be no guarantee or assurance that these transactions will close.

References to Base Plan

References to a Base Plan throughout this presentation refer to an aspirational business plan that is hypothetical, presented for illustrative purposes only and based on a variety of assumptions. There is no guarantee that base plan results indicated herein will be achieved.

References to Certain Investments

Specific references to investments have been provided on a non-performance based criteria for information purposes only. Apollo makes no guarantee that similar investments would be available in the future or, if available, would be profitable. Not all investments shown are currently held by an Apollo Fund.

Assets Under Management

Assets under management, or "AUM", is defined in the Definitions pages. Please note that certain references to AUM provided herein may include totals from different Apollo Funds, or investments from different segments in order to present strategy related information. In addition, certain AUM figures presented herein may be rounded and as a result of certain rounding differences, totals may not reconcile with overall AUM.

Ratings Information

Apollo, its affiliates, and third parties that provide information to Apollo, such as rating agencies, do not guarantee the accuracy, completeness, timeliness or availability of any information, including ratings, and are not responsible for any errors or omissions (negligent or otherwise), regardless of the cause, or the results obtained from the use of such content. Apollo, its affiliates and third party content providers give no express or implied warranties, including, but not limited to, any warranties of merchantability or fitness for a particular purpose or use, and they expressly disclaim any responsibility or liability for direct, indirect, incidental, exemplary, compensatory, punitive, special or consequential damages, costs expenses, legal fees or losses (including lost income or profits and opportunity costs) in connection with the use of the information herein. Credit ratings are statements of opinions and not statements of facts or recommendations to purchase, hold or sell securities. They do not address the suitability of securities for investment purposes and should not be relied on as investment advice. Neither Apollo nor any of its respective affiliates have any responsibility to update any of the information provided in this summary document.

Please see the Forward Looking Statements and Important Disclosures pages and Definitions pages for additional important disclosures and definitions. Historical definitions of certain terms used herein may differ from current definitions.

In addition, information about factors affecting Apollo and Athene, including a description of risks that should be considered when making a decision to purchase or sell any securities of Apollo and Athene, can be found in each company's public filings with the SEC that are available at <http://www.sec.gov>.

Definitions

Pro forma for the merger with Athene, we expect the combined company will present its reportable business segments as asset management, retirement services and principal investing, and will report "Fee Related Earnings", "Spread Related Earnings", and "Principal Investing Income", for each segment, respectively. The asset management segment is expected to include Apollo's alternative asset management business with a focus on three strategies - yield, equity and hybrid. The retirement services segment is expected to include Athene's business which issues and reinsures retirement savings products. The principal investing segment is expected to include Apollo's strategic equity investments and performance allocations from the funds it manages, as well as certain corporate and financing activities. "Pre-tax Distributable Earnings" is the sum of (i) Fee Related Earnings, (ii) Spread Related Earnings, and (iii) Principal Investing Income and is expected to be the key performance measure used by management in evaluating the performance of the combined segments.

For current and historical periods presented in this presentation, Segment Distributable Earnings, Distributable Earnings, Fee Related Earnings, and Spread Related Earnings have the meanings set forth below:

"Segment Distributable Earnings" or "Segment DE" is the key performance measure used by management in evaluating the performance of Apollo's credit, private equity and real assets segments. Management uses Segment DE to make key operating decisions such as the following:

- Decisions related to the allocation of resources such as staffing decisions including hiring and locations for deployment of the new hires;
- Decisions related to capital deployment such as providing capital to facilitate growth for the business and/or to facilitate expansion into new businesses;
- Decisions related to expenses, such as determining annual discretionary bonuses and equity-based compensation awards to its employees. With respect to compensation, management seeks to align the interests of certain professionals and selected other individuals with those of the investors in the funds and those of Apollo's stockholders by providing such individuals a profit sharing interest in the performance fees earned in relation to the funds. To achieve that objective, a certain amount of compensation is based on Apollo's performance and growth for the year; and
- Decisions related to the amount of earnings available for dividends to Class A Common Stockholders, holders of RSUs that participate in dividends and holders of AOG Units.

Segment DE is the sum of (i) total management fees and advisory and transaction fees, (ii) other income (loss), (iii) realized performance fees, excluding realizations received in the form of shares and (iv) realized investment income, net which includes dividends from our permanent capital vehicles, net of amounts to be distributed to certain employees as part of a dividend compensation program, less (x) compensation expense, excluding the expense related to equity-based awards, (y) realized profit sharing expense, and (z) non-compensation expenses. Segment DE represents the amount of Apollo's net realized earnings, excluding the effects of the consolidation of any of the related funds and SPACs, Taxes and Related Payables, transaction-related charges and any acquisitions. Transaction-related charges includes equity-based compensation charges, the amortization of intangible assets, contingent consideration, and certain other charges associated with acquisitions, and restructuring charges. In addition, Segment DE excludes non-cash revenue and expense related to equity awards granted by unconsolidated related parties to employees of the Company, compensation and administrative related expense reimbursements, as well as the assets, liabilities and operating results of the funds and VIEs that are included in the consolidated financial statements.

"Distributable Earnings" or "DE" represents Segment DE less estimated current corporate, local and non-U.S. taxes as well as the current payable under Apollo's tax receivable agreement. DE is net of preferred dividends, if any, to the Series A and Series B Preferred Stockholders. DE excludes the impacts of the remeasurement of deferred tax assets and liabilities which arises from changes in estimated future tax rates. The economic assumptions and methodologies that impact the implied income tax provision are similar to those methodologies and certain assumptions used in calculating the income tax provision for Apollo's consolidated statements of operations under U.S. GAAP. Specifically, certain deductions considered in the income tax provision under U.S. GAAP such as the deduction for transaction related charges and equity-based compensation are taken into account for purposes of the implied tax provision. Management believes that excluding the remeasurement of the tax receivable agreement and deferred taxes from Segment DE and DE, respectively, is meaningful as it increases comparability between periods. Remeasurement of the tax receivable agreement and deferred taxes are estimates that may change due to changes in interpretations of tax law.

"Fee Related Earnings", or "FRE", is derived from our segment reported results and refers to a component of DE that is used as a supplemental performance measure to assess whether revenues that we believe are generally more stable and predictable in nature, primarily consisting of management fees, are sufficient to cover associated operating expenses and generate profits. FRE is the sum across all segments of (i) management fees, (ii) advisory and transaction fees, (iii) performance fees related to business development companies, Redding Ridge Holdings, and MidCap and (iv) other income, net, less (x) salary, bonus and benefits, excluding equity-based compensation (y) other associated operating expenses and (z) non-controlling interests in the management companies of certain funds the Company manages.

"Spread Related Earnings", or "SRE" is derived from segment reported results and refers to a component of DE that is used as a supplemental performance measure to assess the performance of the Retirement Services segment excluding certain market volatility and expenses related to integration, restructuring, equity-based compensation, and other expenses. For the Retirement Services segment, SRE equals the sum of (i) the net investment income earned on Athene's net invested assets and (ii) management fees earned on the ADIP share of ACRA assets, less (x) cost of funds, including cost of crediting and other liability costs, (y) operating expenses excluding equity-based compensation and (z) financing costs including interest expense and preferred dividends paid to Athene Preferred Stockholders.

Definitions

For future periods presented in this presentation, which are pro-forma for the merger with Athene and assume the establishment of asset management, retirement services and principal investing as the combined company's reportable business segments, Fee Related Earnings, Spread Related Earnings, Principal Investing Income, Distributable Earnings and Pre-tax Distributable Earnings have the meanings set forth below:

"**Fee Related Earnings**", or "**FRE**", is derived from segment reported results and refers to a component of DE that is used as a supplemental performance measure to assess the performance of the asset management segment. FRE is the sum of (i) management fees, (ii) advisory and transaction fees, (iii) performance fees related to business development companies, Redding Ridge Holdings, and MidCap and (iv) other income, net, less (x) salary, bonus and benefits, excluding equity-based compensation (y) other associated operating expenses and (z) non-controlling interests in the management companies of certain funds the Company manages.

"**Spread Related Earnings**", or "**SRE**" is derived from segment reported results and refers to a component of DE that is used as a supplemental performance measure to assess the performance of the Retirement Services segment excluding certain market volatility and expenses related to integration, restructuring, equity-based compensation, and other expenses. For the Retirement Services segment, SRE equals the sum of (i) the net investment income earned on Athene's net invested assets and (ii) management fees earned on the ADIP share of ACRA assets, less (x) cost of funds, including cost of crediting and other liability costs, (y) operating expenses excluding equity-based compensation and (z) financing costs including interest expense and preferred dividends paid to Athene Preferred Stockholders.

"**Principal Investing Income**", or "**PII**" is derived from segment reported results and refers to a component of DE that is used as a supplemental performance measure to assess the performance of the Principal Investing segment. For the Principal Investing segment, PII is the sum of (i) realized performance fees, excluding realizations received in the form of shares, (ii) realized investment income, net which includes dividends from our permanent capital vehicles, net of amounts to be distributed to certain employees as part of a dividend compensation program, less (x) compensation expense, excluding expense related to equity-based compensation, (y) realized profit sharing expense, and (z) certain corporate non-compensation expenses and financing costs including preferred dividends, if any, paid to the Apollo Preferred Stockholders.

"**Pre-tax Distributable Earnings**", or "**Pre-tax DE**", is the key performance measure used by management in evaluating the performance of the asset management, retirement services and principal investing segments. Management uses Pre-tax DE to make key operating decisions such as the following:

- Decisions related to the allocation of resources such as staffing decisions including hiring and locations for deployment of the new hires;
- Decisions related to capital deployment such as providing capital to facilitate growth for the business and/or to facilitate expansion into new businesses;
- Decisions related to expenses, such as determining annual discretionary bonuses and equity-based compensation awards to its employees. With respect to compensation, management seeks to align the interests of certain professionals and selected other individuals with those of the investors in the funds and those of Apollo's stockholders by providing such individuals a profit sharing interest in the performance fees earned in relation to the funds. To achieve that objective, a certain amount of compensation is based on Apollo's performance and growth for the year; and
- Decisions related to the amount of earnings available for dividends to Class A Common Stockholders and holders of RSUs that participate in dividends.

Pre-tax DE is the sum of (i) Fee Related Earnings, (ii) Spread Related Earnings, and (iii) Principal Investing Income. Pre-tax DE excludes the effects of the consolidation of any of the related funds and SPACs, Taxes and Related Payables, transaction-related charges and any acquisitions. Transaction-related charges includes equity-based compensation charges, the amortization of intangible assets, contingent consideration, and certain other charges associated with acquisitions, and restructuring charges. In addition, Pre-tax DE excludes non-cash revenue and expense related to equity awards granted by unconsolidated related parties to employees of the Company, compensation and administrative related expense reimbursements, as well as the assets, liabilities and operating results of the funds and VIEs that are included in the consolidated financial statements.

"**Distributable Earnings**" or "**DE**" represents Pre-tax DE less estimated income taxes. Income taxes on FRE and PII represents the total current corporate, local, and non-U.S. taxes as well as the current payable under Apollo's tax receivable agreement. Income taxes on FRE and PII excludes the impacts of deferred taxes and the remeasurement of the tax receivable agreement, which arise from changes in estimated future tax rates. Certain assumptions and methodologies that impact the implied FRE and PII income tax provision are similar to those used under U.S. GAAP. Specifically, certain deductions considered in the income tax provision under U.S. GAAP relating to transaction related charges and equity-based compensation are taken into account for the implied tax provision. Income Taxes on SRE represent the total current and deferred tax expense or benefit on income before taxes adjusted to eliminate the impact of the tax expense or benefit associated with the non-operating adjustments. Management believes the methodologies used to compute income taxes on FRE, PII, SRE are meaningful to each segment and increases comparability of income taxes between periods.

Definitions

"ACRA" refers to Athene Co-Invest Reinsurance Affiliate 1A Ltd.

"ADIP" refers to Apollo/Athene Dedicated Investment Program.

"Apollo" refers to Apollo Global Management, Inc., together with its subsidiaries.

"Apollo Operating Group" or "AOG" refers to (i) the limited partnerships and limited liability companies through which Apollo currently operates its businesses and (ii) one or more limited partnerships or limited liability companies formed for the purpose of, among other activities, holding certain of Apollo's gains or losses on its principal investments in the funds.

"Assets Under Management" or "AUM" refers to the assets of the funds, partnerships and accounts to which Apollo provides investment management, advisory, or certain other investment-related services, including, without limitation, capital that such funds, partnerships and accounts have the right to call from investors pursuant to capital commitments. Our AUM equals the sum of:

1. the net asset value ("NAV"), plus used or available leverage and/or capital commitments, or gross assets plus capital commitments, of the yield and certain hybrid funds, partnerships and accounts for which we provide investment management or advisory services, other than certain collateralized loan obligations ("CLOs"), collateralized debt obligations ("CDOs"), and certain permanent capital vehicles, which have a fee-generating basis other than the mark-to-market value of the underlying assets; for certain permanent capital vehicles in yield, gross asset value plus available financing capacity;
2. the fair value of the investments of the equity and certain hybrid funds, partnerships and accounts Apollo manages or advises, plus the capital that such funds, partnerships and accounts are entitled to call from investors pursuant to capital commitments, plus portfolio level financings;
3. the gross asset value associated with the reinsurance investments of the portfolio company assets Apollo manages or advises; and
4. the fair value of any other assets that Apollo manages or advises for the funds, partnerships and accounts to which Apollo provides investment management, advisory, or certain other investment-related services, plus unused credit facilities, including capital commitments to such funds, partnerships and accounts for investments that may require pre-qualification or other conditions before investment plus any other capital commitments to such funds, partnerships and accounts available for investment that are not otherwise included in the clauses above.

Apollo's AUM measure includes Assets Under Management for which Apollo charges either nominal or zero fees. Apollo's AUM measure also includes assets for which Apollo does not have investment discretion, including certain assets for which Apollo earns only investment-related service fees, rather than management or advisory fees. Apollo's definition of AUM is not based on any definition of Assets Under Management contained in its governing documents or in any of Apollo Fund management agreements. Apollo considers multiple factors for determining what should be included in its definition of AUM. Such factors include but are not limited to (1) Apollo's ability to influence the investment decisions for existing and available assets; (2) Apollo's ability to generate income from the underlying assets in its funds; and (3) the AUM measures that Apollo uses internally or believe are used by other investment managers. Given the differences in the investment strategies and structures among other alternative investment managers, Apollo's calculation of AUM may differ from the calculations employed by other investment managers and, as a result, this measure may not be directly comparable to similar measures presented by other investment managers. Apollo's calculation also differs from the manner in which its affiliates registered with the SEC report "Regulatory Assets Under Management" on Form ADV and Form PF in various ways.

Apollo uses AUM, Capital deployed and Dry powder as performance measurements of its investment activities, as well as to monitor fund size in relation to professional resource and infrastructure needs.

- a) "Fee-Generating AUM" or "FGAUM" consists of assets of the funds, partnerships and accounts to which we provide investment management, advisory, or certain other investment-related services and on which we earn management fees, monitoring fees or other investment-related fees pursuant to management or other fee agreements on a basis that varies among the Apollo funds, partnerships and accounts. Management fees are normally based on "net asset value," "gross assets," "adjusted par asset value," "adjusted cost of all unrealized portfolio investments," "capital commitments," "adjusted assets," "stockholders' equity," "invested capital" or "capital contributions," each as defined in the applicable management agreement. Monitoring fees, also referred to as advisory fees, with respect to the structured portfolio company investments of the funds, partnerships and accounts we manage or advise, are generally based on the total value of such structured portfolio company investments, which normally includes leverage, less any portion of such total value that is already considered in Fee-Generating AUM.

"Athene" refers to Athene Holding Ltd. (together with its subsidiaries, "Athene"), a leading retirement services company that issues, reinsures and acquires retirement savings products designed for the increasing number of individuals and institutions seeking to fund retirement needs, and to which Apollo, through its consolidated subsidiary Apollo Insurance Solutions Group LP (formerly known as Athene Asset Management LLC) ("ISG"), provides asset management and advisory services.

Definitions

"**Athora**" refers to a strategic platform that acquires or reinsures blocks of insurance business in the German and broader European life insurance market (collectively, the "Athora Accounts").

"**Advisory**" / "**Other Assets**" refers to certain assets advised by Apollo Asset Management Europe PC LLP ("AAME PC"), a wholly-owned subsidiary of Apollo Asset Management Europe LLP ("AAME"). AAME PC and AAME are subsidiaries of Apollo and are collectively referred to herein as "ISGI".

"**Capital deployed**" or "**Capital deployment**" or "**Deployment**" represents (i) the aggregate amount of capital that has been invested during a given period (including leverage) by our commitment based funds and SIAs that have a defined maturity date, (ii) purchases of investments (net of sales) by our subscription and contribution based funds and mandates (including leverage), (iii) investments originated by certain of our platform companies, net of syndications to our other funds and accounts, but including syndications to third parties, and (iv) third-party investment activity in opportunities sourced by our teams for which we earn a fee and in which we participate. Deployment excludes offsetting short positions, certain credit derivatives, certain short-dated government securities, and involuntary repayment of loans and bonds.

"**FRE margin**" is calculated as Fee Related Earnings divided by fee related revenues (which includes management fees, transaction and advisory fees and certain performance fees), as well as other income attributable to FRE.

"**Gross IRR**" of Accord Series, Structured Credit Recovery and the European Principal Finance funds represents the annualized return of a fund based on the actual timing of all cumulative fund cash flows before management fees, performance fees allocated to the general partner and certain other expenses. Calculations may include certain investors that do not pay fees. The terminal value is the net asset value as of the reporting date. Non-U.S. dollar denominated ("USD") fund cash flows and residual values are converted to USD using the spot rate as of the reporting date. In addition, gross IRRs at the fund level will differ from those at the individual investor level as a result of, among other factors, timing of investor-level inflows and outflows. Gross IRR does not represent the return to any fund investor.

"**Gross IRR**" of Flagship Private Equity and Hybrid Value Fund represents the cumulative investment-related cash flows (i) for a given investment for the fund or funds which made such investment, and (ii) for a given fund, in the relevant fund itself (and not any one investor in the fund), in each case, on the basis of the actual timing of investment inflows and outflows (for unrealized investments assuming disposition on June 30, 2021 or other date specified) aggregated on a gross basis quarterly, and the return is annualized and compounded before management fees, performance fees and certain other expenses (including interest incurred by the fund itself) and measures the returns on the fund's investments as a whole without regard to whether all of the returns would, if distributed, be payable to the fund's investors. In addition, gross IRRs at the fund level will differ from those at the individual investor level as a result of, among other factors, timing of investor-level inflows and outflows. Gross IRR does not represent the return to any fund investor.

"**Gross IRR**" of Real Estate Equity, Hybrid Real Estate and Infrastructure funds represents the cumulative investment-related cash flows in the fund itself (and not any one investor in the fund), on the basis of the actual timing of cash inflows and outflows (for unrealized investments assuming disposition on June 30, 2021 or other date specified) starting on the date that each investment closes, and the return is annualized and compounded before management fees, performance fees, and certain other expenses (including interest incurred by the fund itself) and measures the returns on the fund's investments as a whole without regard to whether all of the returns would, if distributed, be payable to the fund's investors. Non-USD fund cash flows and residual values are converted to USD using the spot rate as of the reporting date. In addition, gross IRRs at the fund level will differ from those at the individual investor level as a result of, among other factors, timing of investor-level inflows and outflows. Gross IRR does not represent the return to any fund investor.

"**Gross MOIC**" means, with respect to a given investment, fund, or the infrastructure performance metrics, the ratio of Total Value to Total Invested Capital. As used in this definition:

- "Realized Value" refers to all cash investment proceeds received by the relevant Apollo Fund, including interest and dividends, but does not give effect to management fees, expenses, incentive compensation or performance fees to be paid by such Apollo Fund.
- "Total Invested Capital" refers to the aggregate cash invested by the relevant Apollo Fund and includes capitalized costs relating to investment activities, if any, but does not give effect to cash pending investment or available for reserves and excludes amounts, if any, invested on a financed basis with leverage facilities.
- "Total Value" represents the sum of the total Realized Value and Unrealized Value of investments.
- "Unrealized Value" refers to the fair value consistent with valuations determined in accordance with generally accepted accounting principles in the United States of America ("U.S. GAAP"), for investments not yet realized and may include payments in kind, accrued interest and dividends receivable, if any, and before the effect of certain taxes. In addition, amounts include committed and funded amounts for certain investments.

"**Gross Return**" of a **yield fund** is the monthly or quarterly time-weighted return that is equal to the percentage change in the value of a fund's portfolio, adjusted for all contributions and withdrawals (cash flows) before the effects of management fees, incentive fees allocated to the general partner, or other fees and expenses. Returns for yield funds are calculated for all funds and accounts in the respective strategies excluding assets for Athene, Athora and certain other entities where Apollo manages or may manage a significant portion of the total company assets. Returns of CLOs represent the gross returns on assets. Returns over multiple periods are calculated by geometrically linking each period's return over time.

Definitions

"Inflows" represents (i) at the individual segment level, subscriptions, commitments, and other increases in available capital, such as acquisitions or leverage, net of inter-segment transfers, and (ii) on an aggregate basis, the sum of inflows across the yield, equity and hybrid business strategies.

"Net IRR" of Accord Series, Structured Credit Recovery and the European Principal Finance funds represents the annualized return of a fund after management fees, performance fees allocated to the general partner and certain other expenses, calculated on investors that pay such fees. The terminal value is the net asset value as of the reporting date. Non-USD fund cash flows and residual values are converted to USD using the spot rate as of the reporting date. In addition, net IRR at the fund level will differ from that at the individual investor level as a result of, among other factors, timing of investor-level inflows and outflows. Net IRR does not represent the return to any fund investor.

"Net IRR" of Flagship Private Equity and Hybrid Value Fund means the gross IRR applicable to the funds, including returns for related parties which may not pay fees or performance fees, net of management fees, certain expenses (including interest incurred or earned by the fund itself) and realized performance fees all offset to the extent of interest income, and measures returns at the fund level on amounts that, if distributed, would be paid to investors of the fund. The timing of cash flows applicable to investments, management fees and certain expenses, may be adjusted for the usage of a fund's subscription facility. To the extent that a fund exceeds all requirements detailed within the applicable fund agreement, the estimated unrealized value is adjusted such that a percentage of up to 20.0% of the unrealized gain is allocated to the general partner of such fund, thereby reducing the balance attributable to fund investors. In addition, net IRR at the fund level will differ from that at the individual investor level as a result of, among other factors, timing of investor-level inflows and outflows. Net IRR does not represent the return to any fund investor.

"Net IRR" of Real Estate Equity, Hybrid Real Estate and Infrastructure represents the cumulative cash flows in the fund (and not any one investor in the fund), on the basis of the actual timing of cash inflows received from and outflows paid to investors of the fund (assuming the ending net asset value as of June 30, 2021 or other date specified is paid to investors), excluding certain non-fee and non-performance fee bearing parties, and the return is annualized and compounded after management fees, performance fees, and certain other expenses (including interest incurred by the fund itself) and measures the returns to investors of the fund as a whole. Non-USD fund cash flows and residual values are converted to USD using the spot rate as of the reporting date. In addition, net IRR at the fund level will differ from that at the individual investor level as a result of, among other factors, timing of investor-level inflows and outflows. Net IRR does not represent the return to any fund investor.

"Permanent Capital" means capital of indefinite duration, which may be withdrawn under certain conditions.

"Permanent Capital Vehicles" refers to (a) assets that are owned by or related to Athene or Athora Holding Ltd. ("Athora Holding" and together with its subsidiaries, "Athora"), (b) assets that are owned by or related to MidCap FinCo Designated Activity Company ("MidCap") and managed by Apollo, (c) assets of publicly traded vehicles managed by Apollo such as Apollo Investment Corporation ("AINV"), Apollo Commercial Real Estate Finance, Inc. ("ARI"), Apollo Tactical Income Fund Inc. ("AIF"), and Apollo Senior Floating Rate Fund Inc. ("AFT"), in each case that do not have redemption provisions or a requirement to return capital to investors upon exiting the investments made with such capital, except as required by applicable law and (d) a non-traded business development company from which Apollo earns certain investment-related service fees. The investment management agreements of AINV, AIF and AFT have one year terms, are reviewed annually and remain in effect only if approved by the boards of directors of such companies or by the affirmative vote of the holders of a majority of the outstanding voting shares of such companies, including in either case, approval by a majority of the directors who are not "interested persons" as defined in the Investment Company Act of 1940. In addition, the investment management agreements of AINV, AIF and AFT may be terminated in certain circumstances upon 60 days' written notice. The investment management agreement of ARI has a one year term and is reviewed annually by ARI's board of directors and may be terminated under certain circumstances by an affirmative vote of at least two-thirds of ARI's independent directors. The investment management or advisory arrangements between each of MidCap and Apollo, Athene and Apollo and Athora and Apollo, may also be terminated under certain circumstances. The agreement pursuant to which Apollo earns certain investment-related service fees from a non-traded business development company may be terminated under certain limited circumstances.

"Redding Ridge" refers to Redding Ridge Asset Management, LLC and its subsidiaries, which is a standalone, self-managed asset management business established in connection with risk retention rules that manages CLOs and retains the required risk retention interests.

"Vintage Year" refers to the year in which a fund's final capital raise occurred, or, for certain funds, the year of a fund's effective date or the year in which a fund's investment period commences pursuant to its governing agreements.

Non-GAAP Financial Information & Definitions (Athene)

In addition to our results presented in accordance with GAAP, we present certain financial information that includes non-GAAP measures. Management believes the use of these non-GAAP measures, together with the relevant GAAP measures, provides information that may enhance an investor's understanding of our results of operations and the underlying profitability drivers of our business. The majority of these non-GAAP measures are intended to remove from the results of operations the impact of market volatility (other than with respect to alternative investments) as well as integration, restructuring and certain other expenses which are not part of our underlying profitability drivers, as such items fluctuate from period to period in a manner inconsistent with these drivers. These measures should be considered supplementary to our results in accordance with GAAP and should not be viewed as a substitute for the corresponding GAAP measures.

Adjusted Operating Income (Loss) Available to Common Shareholders

Adjusted operating income (loss) available to common shareholders is a non-GAAP measure used to evaluate our financial performance excluding market volatility and expenses related to integration, restructuring, stock compensation and other expenses. Our adjusted operating income (loss) available to common shareholders equals net income (loss) available to AHL common shareholders adjusted to eliminate the impact of the following (collectively, the non-operating adjustments):

- **Investment Gains (Losses), Net of Offsets**—Consists of the realized gains and losses on the sale of AFS securities, the change in fair value of reinsurance assets, unrealized gains and losses, changes in the credit loss allowance, and other investment gains and losses. Unrealized, allowances and other investment gains and losses are comprised of the fair value adjustments of trading securities (other than CLOs) and investments held under the fair value option, derivative gains and losses not hedging FIA index credits, and the change in credit loss allowances recognized in operations net of the change in AmerUs Closed Block fair value reserve related to the corresponding change in fair value of investments. Investment gains and losses are net of offsets related to DAC, DSI, and VOBA amortization and changes to guaranteed lifetime withdrawal benefit (GLWB) and guaranteed minimum death benefit (GMDB) reserves (together, GLWB and GMDB reserves represent rider reserves) as well as the market value adjustments (MVA) associated with surrenders or terminations of contracts.
- **Change in Fair Values of Derivatives and Embedded Derivatives – FIAs, Net of Offsets**—Consists of impacts related to the fair value accounting for derivatives hedging the FIA index credits and the related embedded derivative liability fluctuations from period to period. The index reserve is measured at fair value for the current period and all periods beyond the current policyholder index term. However, the FIA hedging derivatives are purchased to hedge only the current index period. Upon policyholder renewal at the end of the period, new FIA hedging derivatives are purchased to align with the new term. The difference in duration between the FIA hedging derivatives and the index credit reserves creates a timing difference in earnings. This timing difference of the FIA hedging derivatives and index credit reserves is included as a non-operating adjustment, net of offsets related to DAC, DSI, and VOBA amortization and changes to rider reserves.

We primarily hedge with options that align with the index terms of our FIA products (typically 1-2 years). On an economic basis, we believe this is suitable because policyholder accounts are credited with index performance at the end of each index term. However, because the term of an embedded derivative in an FIA contract is longer-dated, there is a duration mismatch which may lead to mismatches for accounting purposes.

- **Integration, Restructuring, and Other Non-operating Expenses**—Consists of restructuring and integration expenses related to acquisitions and block reinsurance costs as well as certain other expenses, which are not predictable or related to our underlying profitability drivers.
- **Stock Compensation Expense**—Consists of stock compensation expenses associated with our share incentive plans, excluding our long-term incentive plan, which are not related to our underlying profitability drivers and fluctuate from time to time due to the structure of our plans.
- **Income Tax (Expense) Benefit – Non-operating**—Consists of the income tax effect of non-operating adjustments and is computed by applying the appropriate jurisdiction's tax rate to the non-operating adjustments that are subject to income tax.

We consider these non-operating adjustments to be meaningful adjustments to net income (loss) available to AHL common shareholders for the reasons discussed in greater detail above. Accordingly, we believe using a measure which excludes the impact of these items is useful in analyzing our business performance and the trends in our results of operations. Together with net income (loss) available to AHL common shareholders, we believe adjusted operating income (loss) available to common shareholders provides a meaningful financial metric that helps investors understand our underlying results and profitability. Adjusted operating income (loss) available to common shareholders should not be used as a substitute for net income (loss) available to AHL common shareholders.

Non-GAAP Financial Information & Definitions (Athene) Cont'd

Adjusted Operating ROE

Adjusted operating ROE is a non-GAAP measure used to evaluate our financial performance excluding the impacts of AOCI and the cumulative change in fair value of funds withheld and modco reinsurance assets, net of DAC, DSI, rider reserve and tax offsets. Adjusted AHL common shareholders' equity is calculated as the ending AHL shareholders' equity excluding AOCI, the cumulative change in fair value of funds withheld and modco reinsurance assets and preferred stock. Adjusted operating ROE is calculated as the adjusted operating income (loss) available to common shareholders, divided by average adjusted AHL common shareholders' equity. These adjustments fluctuate period to period in a manner inconsistent with our underlying profitability drivers as the majority of such fluctuation is related to the market volatility of the unrealized gains and losses associated with our AFS securities. Except with respect to reinvestment activity relating to acquired blocks of businesses, we typically buy and hold AFS investments to maturity throughout the duration of market fluctuations, therefore, the period-over-period impacts in unrealized gains and losses are not necessarily indicative of current operating fundamentals or future performance. Accordingly, we believe using measures which exclude AOCI and the cumulative change in fair value of funds withheld and modco reinsurance assets are useful in analyzing trends in our operating results. To enhance the ability to analyze these measures across periods, interim periods are annualized. Adjusted operating ROE should not be used as a substitute for ROE. However, we believe the adjustments to net income (loss) available to AHL common shareholders and AHL common shareholders' equity are significant to gaining an understanding of our overall financial performance.

Invested Assets

In managing our business, we analyze net invested assets, which does not correspond to total investments, including investments in related parties, as disclosed in our consolidated financial statements and notes thereto. Net invested assets represents the investments that directly back our net reserve liabilities as well as surplus assets. Net invested assets, excluding our investment in Apollo, is used in the computation of net investment earned rate, which allows us to analyze the profitability of our investment portfolio. Net invested assets includes (a) total investments on the consolidated balance sheets with AFS securities at cost or amortized cost, excluding derivatives, (b) cash and cash equivalents and restricted cash, (c) investments in related parties, (d) accrued investment income, (e) VIE assets, liabilities and noncontrolling interest adjustments, (f) net investment payables and receivables, (g) policy loans ceded (which offset the direct policy loans in total investments) and (h) an allowance for credit losses. Net invested assets also excludes assets associated with funds withheld liabilities related to business exited through reinsurance agreements and derivative collateral (offsetting the related cash positions). We include the underlying investments supporting our assumed funds withheld and modco agreements in our net invested assets calculation in order to match the assets with the income received. We believe the adjustments for reinsurance provide a view of the assets for which we have economic exposure. Net invested assets includes our proportionate share of ACRA investments, based on our economic ownership, but does not include the proportionate share of investments associated with the noncontrolling interest. Net invested assets also includes our investment in Apollo. Our net invested assets, excluding our investment in Apollo, are averaged over the number of quarters in the relevant period to compute our net investment earned rate for such period. While we believe net invested assets is a meaningful financial metric and enhances our understanding of the underlying drivers of our investment portfolio, it should not be used as a substitute for total investments, including related parties, presented under GAAP.

Reserve Liabilities

In managing our business, we also analyze net reserve liabilities, which does not correspond to total liabilities as disclosed in our consolidated financial statements and notes thereto. Net reserve liabilities represent our policyholder liability obligations net of reinsurance and is used to analyze the costs of our liabilities. Net reserve liabilities include (a) the interest sensitive contract liabilities, (b) future policy benefits, (c) dividends payable to policyholders, and (d) other policy claims and benefits, offset by reinsurance recoverable, excluding policy loans ceded. Net reserve liabilities include our proportionate share of ACRA reserve liabilities, based on our economic ownership, but does not include the proportionate share of reserve liabilities associated with the noncontrolling interest. Net reserve liabilities is net of the ceded liabilities to third-party reinsurers as the costs of the liabilities are passed to such reinsurers and, therefore, we have no net economic exposure to such liabilities, assuming our reinsurance counterparties perform under our agreements. The majority of our ceded reinsurance is a result of reinsuring large blocks of life business following acquisitions. For such transactions, GAAP requires the ceded liabilities and related reinsurance recoverables to continue to be recorded in our consolidated financial statements despite the transfer of economic risk to the counterparty in connection with the reinsurance transaction. While we believe net reserve liabilities is a meaningful financial metric and enhances our understanding of the underlying profitability drivers of our business, it should not be used as a substitute for total liabilities presented under GAAP.

Sales

Sales statistics do not correspond to revenues under GAAP but are used as relevant measures to understand our business performance as it relates to inflows generated during a specific period of time. Our sales statistics include inflows for fixed rate annuities and FIAs and align with the LIMRA definition of all money paid into an individual annuity, including money paid into new contracts with initial purchase occurring in the specified period and existing contracts with initial purchase occurring prior to the specified period (excluding internal transfers). While we believe sales is a meaningful metric and enhances our understanding of our business performance, it should not be used as a substitute for premiums presented under GAAP.

Non-GAAP Financial Information & Definitions (Athene) Cont'd

Adjusted Operating ROA

Adjusted operating ROA is a non-GAAP measure used to evaluate our financial performance and profitability. Adjusted operating ROA is computed using our adjusted operating income (loss) available to common shareholders divided by average net invested assets for the relevant period. To enhance the ability to analyze this measure across periods, interim periods are annualized. While we believe this metric is a meaningful financial metric and enhances our understanding of the underlying profitability drivers of our business, it should not be used as a substitute for ROA presented under GAAP.

Net Investment Spread, Investment Margin on Deferred Annuities and Operating Expenses

Net investment spread is a key measure of profitability. Net investment spread measures our investment performance less the total cost of our liabilities. Net investment earned rate is a key measure of our investment performance, while cost of funds is a key measure of the cost of our policyholder benefits and liabilities. Investment margin on our deferred annuities measures our investment performance less the cost of crediting for our deferred annuities, which make up a significant portion of our net reserve liabilities.

Net investment earned rate is a non-GAAP measure we use to evaluate the performance of our net invested assets that does not correspond to GAAP net investment income. Net investment earned rate is computed as the income from our net invested assets divided by the average net invested assets, excluding the impacts of our investment in Apollo, for the relevant period. To enhance the ability to analyze these measures across periods, interim periods are annualized. The adjustments to net investment income to arrive at our net investment earned rate add (a) alternative investment gains and losses, (b) gains and losses related to trading securities for CLOs, (c) net VIE impacts (revenues, expenses and noncontrolling interest), (d) forward points gains and losses on foreign exchange derivative hedges and (e) the change in fair value of reinsurance assets, and removes the proportionate share of the ACRA net investment income associated with the ACRA noncontrolling interest as well as the gain or loss on our investment in Apollo. We include the income and assets supporting our change in fair value of reinsurance assets by evaluating the underlying investments of the funds withheld at interest receivables and we include the net investment income from those underlying investments which does not correspond to the GAAP presentation of change in fair value of reinsurance assets. We exclude the income and assets supporting business that we have exited through ceded reinsurance including funds withheld agreements. We believe the adjustments for reinsurance provide a net investment earned rate on the assets for which we have economic exposure.

Cost of funds includes liability costs related to cost of crediting on both deferred annuities and institutional products as well as other liability costs, but does not include the proportionate share of the ACRA cost of funds associated with the noncontrolling interest. Cost of funds is computed as the total liability costs divided by the average net invested assets, excluding our investment in Apollo, for the relevant period. To enhance the ability to analyze these measures across periods, interim periods are annualized.

Cost of crediting includes the costs for both deferred annuities and institutional products. Cost of crediting on deferred annuities is the interest credited to the policyholders on our fixed strategies as well as the option costs on the indexed annuity strategies. With respect to FIAs, the cost of providing index credits includes the expenses incurred to fund the annual index credits, and where applicable, minimum guaranteed interest credited. Cost of crediting on institutional products is comprised of (i) PRT costs, including interest credited, benefit payments and other reserve changes, net of premiums received when issued, and (ii) funding agreement costs, including the interest payments and other reserve changes. Cost of crediting is computed as the cost of crediting for deferred annuities and institutional products divided by the average net invested assets, excluding the investment in Apollo, for the relevant periods. Cost of crediting on deferred annuities is computed as the net interest credited on fixed strategies and option costs on indexed annuity strategies divided by the average net account value of our deferred annuities. Cost of crediting on institutional products is computed as the PRT and funding agreement costs divided by the average net institutional reserve liabilities. Our average net invested assets, excluding our investment in Apollo, net account values and net institutional reserve liabilities are averaged over the number of quarters in the relevant period to obtain our associated cost of crediting for such period. To enhance the ability to analyze these measures across periods, interim periods are annualized.

Other liability costs include DAC, DSI and VOBA amortization, change in rider reserves, the cost of liabilities on products other than deferred annuities and institutional products, excise taxes, premiums, product charges and other revenues. We believe a measure like other liability costs is useful in analyzing the trends of our core business operations and profitability. While we believe other liability costs is a meaningful financial metric and enhances our understanding of the underlying profitability drivers of our business, it should not be used as a substitute for total benefits and expenses presented under GAAP.

Net investment earned rate, cost of funds, net investment spread and investment margin on deferred annuities are non-GAAP measures we use to evaluate the profitability of our business. We believe these metrics are useful in analyzing the trends of our business operations, profitability and pricing discipline. While we believe each of these metrics are meaningful financial metrics and enhance our understanding of the underlying profitability drivers of our business, they should not be used as a substitute for net investment income, interest sensitive contract benefits or total benefits and expenses presented under GAAP.

Operating expenses excludes integration, restructuring and other non-operating expenses, stock compensation expense, interest expense and policy acquisition expenses. We believe a measure like operating expenses is useful in analyzing the trends of our core business operations and profitability. While we believe operating expenses is a meaningful financial metric and enhances our understanding of the underlying profitability drivers of our business, it should not be used as a substitute for policy and other operating expenses presented under GAAP.

Non-GAAP Financial Information & Definitions (Athene) Cont'd

Adjusted Operating Common Shares Outstanding and Adjusted Book Value Per Common Share

Adjusted operating common shares outstanding and adjusted book value per common share are non-GAAP measures used to evaluate our financial performance and financial condition. The non-GAAP measures adjust the number of shares included in the corresponding GAAP measures to reflect the conversion or settlement of all shares and other stock-based awards outstanding. We believe these measures represent an economic view of our share counts and provide a simplified and consistent view of our outstanding shares. Adjusted book value per common share is calculated as the adjusted AHL common shareholders' equity divided by the adjusted operating common shares outstanding. Effective February 28, 2020, all Class B common shares were converted into Class A common shares and all Class M common shares were converted into warrants and Class A common shares. Our Class B common shares were economically equivalent to Class A common shares and were convertible to Class A common shares on a one-for-one basis at any time. Our Class M common shares were in the legal form of shares but economically functioned as options as they were convertible into Class A common shares after vesting and payment of the conversion price. Adjusted operating common shares outstanding assumes conversion or settlement of all outstanding items that are able to be converted to or settled in Class A common shares, including the impacts of Class B common shares on a one-for-one basis, the impacts of all Class M common shares net of the conversion price and any other stock-based awards, but excluding any awards for which the exercise or conversion price exceeds the market value of our Class A common shares on the applicable measurement date. For certain historical periods, Class M shares were not included due to issuance restrictions which were contingent upon our IPO. Adjusted operating common shares outstanding and adjusted book value per common share should not be used as a substitute for common shares outstanding – Class A or book value per common share. However, we believe the adjustments to the shares and equity are significant to gaining an understanding of our overall results of operations and financial condition.

Adjusted Debt to Capital Ratio

Adjusted debt to capital ratio is a non-GAAP measure used to evaluate our capital structure excluding the impacts of AOCI and the cumulative change in fair value of funds withheld and modco reinsurance assets, net of DAC, DSI, rider reserve and tax offsets. Adjusted debt to capital ratio is calculated as total debt divided by adjusted AHL shareholders' equity. Adjusted debt to capital ratio should not be used as a substitute for the debt to capital ratio. However, we believe the adjustments to shareholders' equity are significant to gaining an understanding of our capitalization, debt utilization and debt capacity.

INVESTOR
DAY 2021

Endnotes



Endnotes

STRATEGY & OUTLOOK

We Produce Excess Return Across the Risk Spectrum

1. As of 1Q21, trailing 5-year average yield of comparable quality and duration US corporate bond indices at the time of HGA Investment Grade Issuance or Purchase.
2. Peers represent a weighted average of AEL, AIG, AFG, FGL, LNC, MET, PRU, and PFG for the 5 years 2016 to 2020. Source: SNL Financial, Company Filings. Net asset yield calculated based on average stat investment yield on bonds and mortgages disclosed in annual U.S. life insurance statutory filings. Stat investment yield reduced for each company's respective investment fees and expenses approximated by taking annual GAAP investment expenses divided by average GAAP invested assets. Athene's stat investment yield was adjusted to include assets in Bermuda entities and separate accounts backing pension risk transfer transactions, and to back out the impact of the larger Lincoln and Jackson National block trades during their respective 12 months deployment periods, as well as the impact of PRT transactions >\$750mm that closed in December on yields in the year that they closed. The Apollo Large Corporate Credit universe was selected to include publicly priced syndicated loans, denominated in USD, that had at least \$100mm of market value held across the Apollo credit platform from January 2015 to June 2021. Market value includes accrued income. P&L and returns exclude FX gains and losses as well as cash and cash equivalents. Returns are calculated daily on a gross basis and are geometrically linked, annualized and assumes one turn of leverage with no cost of leverage.
3. As provided by ThomsonOne. Represents total U.S. Credit Opportunities, Senior Debt and Subordinated Capital funds with 2018 vintages net IRR through Q1 2021.
4. Reflects composite returns of Accord Fund I, Accord Fund II, Accord Fund III, Accord Fund III B and Accord Fund IV from the date of the funding of Accord Fund I's first call in February 2017 through June 30, 2021.
5. As provided by Cambridge Associates, as of Q1 2021. Represents total U.S. Credit Opportunities, Senior Debt and Subordinated Capital funds with 2018 vintages net IRR through Q1 2021. Reflects latest data available.
6. As provided by Cambridge Associates, as of Q1 2021. Represents total U.S. Credit Opportunities, Senior Debt, Subordinated Capital and Buyout funds with 2018 vintages net IRR through Q1 2021. Reflects latest data available.
7. As provided by Cambridge Associates, as of Q1 2021. Reflects latest data available.
8. Flagship PE represents Funds I-IX. Strategy AUM includes co-invest.

Our Flagship Products Have Meaningfully Outperformed

1. Peers represent a weighted average of AEL, AIG, AFG, FGL, LNC, MET, PRU, and PFG for the 5 years 2016 to 2020. Source: SNL Financial, Company Filings. Net asset yield calculated based on average stat investment yield on bonds and mortgages disclosed in annual U.S. life insurance statutory filings. Stat investment yield reduced for each company's respective investment fees and expenses approximated by taking annual GAAP investment expenses divided by average GAAP invested assets. Athene's stat investment yield was adjusted to include assets in Bermuda entities and separate accounts backing pension risk transfer transactions, and to back out the impact of the larger Lincoln and Jackson National block trades during their respective 12 months deployment periods, as well as the impact of PRT transactions >\$750mm that closed in December on yields in the year that they closed. The Apollo Large Corporate Credit universe was selected to include publicly priced syndicated loans, denominated in USD, that had at least \$100mm of market value held across the Apollo credit platform from January 2015 to June 2021. Market value includes accrued income. P&L and returns exclude FX gains and losses as well as cash and cash equivalents. Returns are calculated daily on a gross basis and are geometrically linked, annualized and assumes one turn of leverage with no cost of leverage.
2. Reflects composite returns of Accord Fund I, Accord Fund II, Accord Fund III, Accord Fund III B and Accord Fund IV from the date of the funding of Accord Fund I's first call in February 2017 through June 30, 2021.
3. Benchmark provided by Cambridge Associates, as of Q1 2021. Represents total U.S. Credit Opportunities, Senior Debt and Subordinated Capital funds with 2018 vintages net IRR through Q1 2021. Reflects latest data available.
4. Benchmark provided by Cambridge Associates, as of Q1 2021. Represents total U.S. Credit Opportunities, Senior Debt, Subordinated Capital and Buyout funds with 2018 vintages net IRR through Q1 2021. Reflects latest data available.
5. Flagship PE represents Funds I-IX. Strategy AUM includes co-invest.
6. Benchmark provided by Cambridge Associates, as of Q1 2021. Reflects latest data available.

Endnotes

STRATEGY & OUTLOOK

Athene Has A Simple, Spread-Based Business Model

1. Net asset yield calculated based on average stat investment yield on bonds and mortgages disclosed in annual U.S. life insurance statutory filings. Stat investment yield reduced for each company's respective investment fees and expenses approximated by taking annual GAAP investment expenses divided by average GAAP invested assets. Athene's stat investment yield was adjusted to include assets in Bermuda entities and separate accounts backing pension risk transfer transactions, and to back out the impact of the larger Lincoln and Jackson National block trades during their respective 12 months deployment periods, as well as the impact of PRT transactions >\$750mm that closed in December on yields in the year that they closed.
2. General and administrative expense ratios calculated as U.S. statutory general & administrative expenses divided by average U.S. statutory net total assets.
3. Adjusted operating income for common shareholders excluding Apollo divided by average net invested assets excluding AOG.
4. 13x leverage for illustrative purposes.
5. Adjusted Operating ROE as reported externally.

Athene is Uniquely Positioned in the Industry

1. Athene metrics are net of non-controlling interest in ACRA, as of June 30, 2021. AA-/A+ Rated Companies metrics as of December 31, 2020 per SNL Financial. AA-/A+ Rated Companies are: PFG (A+), PRU (AA-), MET (AA-) and GL (AA-).
2. Refers to adjusted debt-to-capital ratio as of June 30, 2021. AA-/A+ Rated Companies metrics as of December 31, 2020. AA-/A+ Rated Companies are: PFG (A+), PRU (AA-), MET (AA-) and GL (AA-).
3. Peer U.S. statutory impairments per SNL Financial, average includes AEL, AIG, AMP, BHF, EQH, FG, LNC, MET, PFG, PRU, VOYA and Transamerica. For Athene, U.S. statutory data adjusted to include impairments and assets in Bermuda Linked presentations are not incorporated by reference.
4. General and administrative expense ratios calculated as U.S. statutory general & administrative expenses divided by average U.S. statutory net total assets. "Industry" represents a weighted average of AEL, AIG, AFG, FGL, LNC, MET, PRU, and PFG for the 5 years 2016 to 2020.

Athene Represents a Strategic Purchase for Apollo

1. Pre-deal share price as of March 5, 2021. Current share price as of October 15, 2021.
2. Apollo will consolidate 100% of Athene earnings as Apollo does not consolidate earnings on its stake in Athene pre-merger. Excludes reported or forecasted earnings from Athene's investment in Apollo Operating Group.
3. Athene adjusted operating income excludes earnings on stake in Apollo. Pro forma consensus 2021E calculated as consensus pre-tax income, less illustrative assumed taxes at 18% tax rate, less consensus preferred dividends. Consensus as of March 3, 2021 based on average of available research analyst projections.
4. Athene adjusted operating income excludes earnings on stake in Apollo. Pro forma consensus 2021E calculated as consensus pre-tax income, less consensus preferred dividends and taxes. Consensus as of August 8, 2021 based on average of available research analyst projections.

Endnotes

YIELD OVERVIEW

Historical Success by Being a First Mover

1. Net asset yield calculated based on average stat investment yield on bonds and mortgages disclosed in annual U.S. life insurance statutory filings. Stat investment yield reduced for each company's respective investment fees and expenses approximated by taking annual GAAP investment expenses divided by average GAAP invested assets. Athene's stat investment yield was adjusted to include assets in Bermuda entities and separate accounts backing pension risk transfer transactions, and to back out the impact of the larger Lincoln and Jackson National block trades during their respective 12 months deployment periods, as well as the impact of PRT transactions > \$750mm that closed in December on yields in the year that they closed. Peers represent a weighted average of AEL, AIG, AFG, FGL, LNC, MET, PRU, and PFG for the 5 years 2016 to 2020.

EQUITY & HYBRID OVERVIEW

Scaling Strategies Have Large Opportunity for Growth

1. Total Co-Invest includes traditional co-invest and capital sourced and placed by Apollo to third parties outside of Apollo managed funds. Reflected as a multiple of total invested capital raised for relevant strategy, rounded to nearest half.
2. AUM includes Apollo U.S. Real Estate and Asia Real Estate Equity, European Principal Finance, and Hybrid Real Estate. Excess Co-Invest includes Apollo U.S. Real Estate and Asia Real Estate Equity.

RETIREMENT SERVICES OVERVIEW

Our Retirement Services Footprint is Going Global, and the Market Opportunity is Enormous

1. Comprised of: \$1.2 trillion US general account annuities reported on US statutory statements as of year-end 2020 as aggregated by SNL Financial. \$1.4 trillion in US Pension Group Annuities, based on 2020 year-end private-sector defined benefit liabilities per US Federal Reserve, assuming 20% of plans are active and used for employee attraction/retention, and that 50% of the remainder back current retirees and define the market for pension risk transfer. \$1.1 trillion in US Defined Contribution plan annuities applying assumed 15% allocation to the \$7.2 trillion US record keeper market.
2. Comprised of: \$5.5 trillion European Life and Annuities market as of June 30, 2021, per ECB Data Warehouse. \$0.9 trillion UK Pension Risk Transfer Market based on assets backing retirees of closed pension plans as of March 2020 per Pension Protection Fund. \$0.6 trillion EU Pension Risk Transfer Market based on EU pension assets excluding Switzerland per OECD as of 2019, assuming a 90% of assets sit in defined benefit plans and 20% of those assets back current retirees.
3. Comprised of: \$2.4 trillion China Life and Annuities market per China Banking and Insurance Regulatory Commission, \$1.0 trillion Taiwan Life and Annuities market per Taiwan Insurance Institute, \$0.8 trillion Korea Life and Annuities market per Korean Life Insurance Association, and \$0.3 trillion Hong Kong Life and Annuities market per HKIA as of Q4 2019.
4. Japan Life and Annuities market as of March 2020 per Life Insurance Association of Japan 5. \$3.0 trillion AUD (\$2.2 trillion USD) in SuperFunds per APRA as of June 30, 2021, multiplied by a 20% recommend allocation to lifetime annuities in Australian Treasury's Retirement Income Covenant Position Paper (2018).
5. Total superannuation assets in Australia as of June 30, 2021, converted to USD using a 0.75x exchange rate.

Massive Landscape of Upside Opportunities

1. Comprised of: \$2.4 trillion China Life and Annuities market per China Banking and Insurance Regulatory Commission, \$1.0 trillion Taiwan Life and Annuities market per Taiwan Insurance Institute, \$0.8 trillion Korea Life and Annuities market per Korean Life Insurance Association, \$0.3 trillion Hong Kong Life and Annuities market per HKIA as of Q4 2019, and \$3.0 trillion Japan Life and Annuities market as of March 2020 per Life Insurance Association of Japan.
2. As of June 30, 2021. Source: ECB Data Warehouse.
3. 2020 year-end private-sector defined benefit liabilities per US Federal Reserve, assuming 20% of plans are active and used for employee attraction/retention, and that 50% of the remainder back current retirees and determine the market for pension risk transfer.
4. Comprised of: \$0.9 trillion UK Pension Risk Transfer Market based on assets backing retirees of closed pension plans as of March 2020 per Pension Protection Fund and \$0.6 trillion EU Pension Risk Transfer Market based on total EU pension assets excluding Switzerland per OECD as of 2019, assuming a 90% of assets sit in defined benefit plans and 20% of those assets back current retirees.

Endnotes

ATHENE

Athene's Advantages Drive Value Creation

1. Net asset yield calculated based on average stat investment yield on bonds and mortgages disclosed in annual U.S. life insurance statutory filings. Stat investment yield reduced for each company's respective investment fees and expenses approximated by taking annual GAAP investment expenses divided by average GAAP invested assets. Athene's stat investment yield was adjusted to include assets in Bermuda entities and separate accounts backing pension risk transfer transactions, and to back out the impact of the larger Lincoln and Jackson National block trades during their respective 12 months deployment periods, as well as the impact of PRT transactions >\$750mm that closed in December on yields in the year that they closed.
2. General and administrative expense ratios calculated as U.S. statutory general & administrative expenses divided by average U.S. statutory net total assets.
3. Peer adjusted operating ROE data calculated as an average of AEL, AIG, AFG, FGL, LNC, MET, PRU, and PFG.

The Opportunity Set is Vast

1. Cumulative inflows since inception for PGA and Funding Agreements, since 2014 for Retail.
2. US Fixed Annuities and Fixed Indexed Annuities combined \$1.2 trillion represents US general account annuities reported on US statutory statements as of year-end 2020 as aggregated by SNL Financial. Split between \$0.7 trillion of cumulative industry sales over assumed duration of 6 years for Fixed Annuities and \$0.5 trillion of cumulative industry sales over assumed duration of 10 years for Fixed Indexed Annuities. Source: JP Morgan Market Share Bible 2021.
3. As of March 2020. Source: Goldman Sachs, Japan Institute of Life Insurance "Life Insurance Fact-finding Survey in Japan".
4. 2020 year-end private-sector defined benefit liabilities per US Federal Reserve, assuming 20% of plans are active and used for employee attraction/retention, and that 50% of the remainder back current retirees and determine the market for pension risk transfer.
5. As of March 2020. Source: Pension Protection Fund.
6. As of September 2021. Sources: BNP Paribas, Bloomberg, EURONEXT / Irish Stock Exchange, Company Filings.

Athene Generates Significant Capital to Fund Growth

1. Cash Flow From Earnings: estimated by changes in Statutory Capital & Surplus of Athene's insurance entities excluding earnings from AOG shares, upfront gains from inorganic activities, and other one-time items.
2. Annual Capital Release from normal-course run-off: Approximate Capital Relief on decremented reserves under Athene's monitored capital models.
3. Excess Equity Capital / Untapped Debt Capacity / Available Capital from Sidecar (ADIP) – as of 6/30/2021.
4. Trailing 3Y includes 3Q'18-2Q'21.

We Run Our Business Aligned with Our Risk Appetite and in Consideration of Historical Events

1. 10yr US Treasury Yield: Feb 19, 2020 to COVID trough on Aug 4, 2020; Spreads: peak daily absolute spreads during 2020; Equity Markets: SPX pre-COVID peak on Feb 19, 2020 to COVID trough on Mar 23, 2021; FI defaults: peak TTM BBB and B US bond default rates during 2020; Housing price: No decline in TTM Corelogic National HPI index during 2020.
2. German 10-year bund yield.
3. Indicative levels, actual absolute spreads determined formulaically based on prevailing market spreads, predetermined spread multipliers and ceilings.
4. Primarily for representative purposes. Stress scenarios apply customized stresses as relevant for Alternatives sub-categories. Adjusted equities recession shock to reflect worst peak to trough drop, in place of average, during recession years (1990-1991, 2001-2002).
5. Excludes Athene's investment in Apollo Operating Group (AOG) units. Assumes mark-to-market impact on alternatives and prefers is unrealized and would be expected to recover over time, consistent with historical and recent experience. Total Excludes Athene's investment in Apollo Operating Group (AOG) units. Mark to market impact on alternatives is unrealized and would be expected to recover over time, consistent with historical and recent experience. Total loss estimate is based upon a single scenario involving a discrete set of assumptions regarding economic conditions. Actual economic conditions in a stressed environments may differ significantly from those assumed and actual loss experience may differ from the estimate presented above and such difference could be material. 2020 STAT earnings and capital released from run-off. Illustrative management action above reflects issuing approximately 50% of Athene's untapped debt capacity as of June 30, 2021.

APOLLO INVESTOR DAY 2021
